



ALL INDUSTRIAL

***CATALOG GENERAL
MOTOARE ELECTRICE***



0746556600

contact@allindustrial.ro

aLLindustriaL.Ro

1	Introducere <i>Introduction</i>	5	Motoare electrice cu frana <i>Brake motors</i>
2	Referinte de reglementare si certificari <i>Certification and reference standards</i>	5.1	Selectarea franelor <i>Brake selection</i>
2.1	Reglementari de referinta <i>Reference standards</i>	5.2	Redresoare <i>Rectifiers</i>
2.2	Certificari <i>Certifications</i>	5.3	Frana S <i>Brake S</i>
2.3	Eficienta si economie de energie <i>Energy savings and efficiency</i>	5.4	Frana K-H <i>Brake K-H</i>
2.4	Domenii de aplicare <i>Fields of application</i>	5.5	Frana H <i>Brake H</i>
2.5	Cronologia standardelor <i>Timeline of standards</i>	5.6	Frana R <i>Brake R</i>
2.6	Compararea standardelor internationale <i>Comparison of international standards</i>	5.7	Frana C <i>Brake C</i>
2.7	Valori minime de eficienta <i>Minimum efficiency values</i>	5.8	Motor cu frana trifazat, cu o viteza <i>Three-phase brake motor, single polarity</i>
3	Specificatii generale <i>General specifications</i>	5.9	Performanta motorului cu frana trifazat, cu polaritate dubla <i>Performance of three-phase brake motor, double polarity</i>
3.1	Citirea cheii si a codului de identificare <i>Reading key and identification code</i>	5.10	Performanta motorului cu frana monofazat <i>Performance of single-phase brake motor</i>
3.2	Marcaje <i>Markings</i>	6	Sectiunea ATEX <i>ATEX Section</i>
3.3	Configuratii si aranjamente de montare <i>Configurations and mounting arrangements</i>	7	Modele speciale de motoare electrice <i>Special designs</i>
3.4	Dimensiuni cuplaj arbore principal-flansa <i>Main Shaft-Flange coupling dimensions</i>	7.1	Protectie electrica <i>Electrical protection</i>
3.5	Materiale si componente <i>Materials and components</i>	7.2	Protectie fizica <i>Physical protection</i>
3.6	Tolerante <i>Tolerances</i>	7.3	Optuni de montare <i>Mounting options</i>
3.7	Niveluri sonore <i>Sound levels</i>	7.4	Certificari <i>Certifications</i>
3.8	Vibratii <i>Vibrations</i>	7.5	Optiuni de asamblare a franelor <i>Brake assembly options</i>
3.9	Metoda de racire <i>Cooling method</i>	7.6	Alte optiuni <i>Other options</i>
3.10	Nivel de protectie IP <i>IP protection level</i>	8	Specificatii dimensionale ale motoarelor trifazate <i>Motors dimensional specifications</i>
3.11	Izolatie si infasurare statorica <i>Insulation and stator winding</i>	8.1	IE3
3.12	Variatiile puterii legate de conditiile de mediu <i>Variations of power related to environmental conditions</i>	8.2	IE2
3.13	Variatia specificatiilor nominale <i>Variation of nominal specifications</i> 3.14	8.3	IE1
	Tipuri de servicii <i>Type of duty</i>	8.4	Polaritate dubla <i>Double polarity</i>
3.15	Directia de rotatie <i>Direction of rotation</i>	8.5	Monofazat <i>Single phase</i>
	Echipament de pornire <i>Starters</i>	8.6	Autofranare <i>Brake motor</i>
3.17	Controlul inverterului <i>Inverter control</i>	8.7	Dimensiunile motoarelor cu servoventilatie forzata si encoder <i>Dimensions of forced cooling and encoder motors</i>
3.18	Sarcini radiale si axiale <i>Radial and axial loads</i>	9	Anexa <i>Appendix</i>
3.19	Rulmenti <i>Bearings</i>	9.1	Piese de schimb <i>Spare parts</i>
3.20	Dimensiunile garniturii de etansare a uleiului <i>Oil seal dimensions</i>	9.2	Diagrame de conectare <i>Connection diagrams</i>
4	Performanta tehnica si specificatii <i>Technical performance and specifications</i>	9.3	Cutie de borne <i>Terminal box</i>
4.1	IE3	9.4	Conditii generale de vanzare <i>General sale terms</i>
4.2	IE2	9.5	Legenda <i>Legend</i>
4.3	IE1	9.6	Indexul tabelor <i>Index of tables</i>
4.4	Motoare trifazate cu doua viteze <i>Three-phase double speed motors</i>		
4.5	Motoare monofazate <i>Single phase motors</i>		

2.0

Standarde de certificare si de referinta *Certification and reference standards*

Motoarele electrice reprezinta coloana vertebrala a industriei moderne, fiind dispozitive electromecanice complexe proiectate pentru a converti energia electrica in energie mecanica cu o eficienta optima. Avand in vedere rolul lor critic in procesele de productie, aceste masini nu sunt doar simple componente, ci sisteme care trebuie sa functioneze sub rigori stricte de siguranta si performanta. Din acest motiv, ele sunt supuse unui cadru vast de reglementari internationale si directive europene, menite sa garanteze nu doar functionarea lor in parametrii nominali, ci si protectia personalului si a infrastructurii in diverse medii de instalare.

Obiectivul Documentatiei de Certificare

Scopul acestei sectiuni este de a functiona ca un ghid tehnic si legislativ comprehensiv. Intr-o piata globalizata, alegerea unui motor electric nu se bazeaza doar pe puterea livrata sau pe turatie, ci si pe conformitatea acestuia cu specificatiile tehnice de reglementare specifice fiecarei regiuni sau aplicatii industriale. Aceasta imagine de ansamblu este conceputa pentru a va sprijini in procesul de identificare a produsului ideal, asigurandu-va ca motorul selectat indeplineste toate standardele de siguranta, eficienta energetica si compatibilitate cerute de proiectul dumneavoastra.

Clasificare si Diferentiere Tehnica

Motoarele electrice se diferentiaza printr-o serie de caracteristici esentiale care determina aplicabilitatea lor in medii standard sau in conditii de lucru extreme (cum ar fi atmosferele potential explozive sau mediile cu umiditate ridicata). Printre principalele criterii de diferentiere se numara:

Clasele de eficienta energetica (IE1, IE2, IE3, IE4): Reglementate pentru a reduce impactul asupra mediului si costurile operationale.

Gradul de protectie (IP): Esential pentru determinarea rezistentei la praf si lichide.

Tipul de serviciu (S1 - S10): Care defineste regimul de functionare (continuu, intermitent etc.).

Certificarile specifice de siguranta: Precum marcajul CE, certificarile ATEX pentru medii explozive sau standardele IEC/NEMA.

Angajamentul aLLindustrial fata de Standarde Globale

Excelenta operationala a companiei aLLindustrial este sustinuta de un portofoliu solid de certificari internationale. Aceste acreditari nu reprezinta doar o confirmare a calitatii produselor noastre, ci constituie pasaportul tehnic care ne permite sa operam si sa livram solutii tehnologice in intreaga lume. Prin respectarea stricta a standardelor de referinta, ne asiguram ca fiecare unitate furnizata este capabila sa integreze cele mai noi inovatii in domeniul sigurantei electrice si al sustenabilitatii, oferind partenerilor nostri siguranta unei investitii fiabile pe termen lung.

◆ 2.1 Reglementari de referinta / *Reference standards*

CEI	IEC	Titlu	Title
EN 60034-1	60034-1	Specificatii nominale si de functionare	<i>Nominal and operating specifications</i>
EN 60034-2	60034-2	Metode de determinare a pierderilor si a eficientei	<i>Methods of determining losses and efficiency</i>
EN 60034-5	60034-5	Clasificarea nivelurilor de protectie (cod IP)	<i>Classification of protection levels (IP code)</i>
EN 60034-6	60034-6	Metode de racire (cod IC)	<i>Cooling methods (IC code)</i>
EN 60034-7	60034-7	Tipuri de constructie, configuratie si pozitionare a cutiei de borne (cod IN)	<i>Types of construction, configuration and position of terminal box (IM code)</i>
EN 60034-8	60034-8	Marcajele terminalanelor si directia de rotatie	<i>Terminal markings and direction of rotation</i>
EN 60034-9	60034-9	Limite sonore	<i>Sound limits</i>
60034-11	60034-11	Izolatie termica la bord	<i>On-board thermal insulation</i>
EN 60034-12	60034-12	Performanta electrica a masinilor electrice rotative la pornire	<i>Electrical performance of rotating electric machines at start-up</i>
EN 60034-14	60034-14	Vibratiile mecanice ale masinilor rotative	<i>Mechanical vibrations of rotating machines</i>
IEC 60034-30 Ed. 1		Clasa de eficienta a motoarelor asincrone trifazate cu o singura viteza, incapsulate in carcasa (cod IE)	<i>Efficiency class of asynchronous three-phase single speed caged motors (code IE)</i>
EN 50347	60072-1	Dimensiuni si randamente ale masinilor rotative	<i>Dimensions and outputs of rotating machines</i>
EN 50347	60072-2		
16-8	1293	Marcaje pentru echipamente electrice	<i>Electrical equipment markings</i>
IEC TS 60034-25		Ghid pentru proiectarea si performanta motoarelor de curent alternativ, special concepute pentru controlul invertorului (Specificatie tehnica)	<i>Guide to the design and performance of alternate current motors, specifically designed for inverter control (Technical specification)</i>
IEC TS 60034-18-41		Calificare si teste de tip pentru sistemele de izolatie de tip I utilizate in masinile rotative controlate de invertor (Specificatie tehnica)	<i>Qualification and type tests for type I insulation systems used in inverter controlled rotating machines (Technical specification)</i>
UNI ISO 2768/1-2		Tolerante generale	<i>General tolerances</i>
UNI 321		Capat de arbore	<i>Shaft end</i>
2014/35/EU (LVD)		Directiva de joasa tensiune	<i>Low voltage directive</i>
2014/30/EU (EMC)		Directiva privind compatibilitatea electromagnetica	<i>Electromagnetic compatibility directive</i>
2006/42/CE		Directiva privind masinile	<i>Machinery directive</i>

(tab. 1)

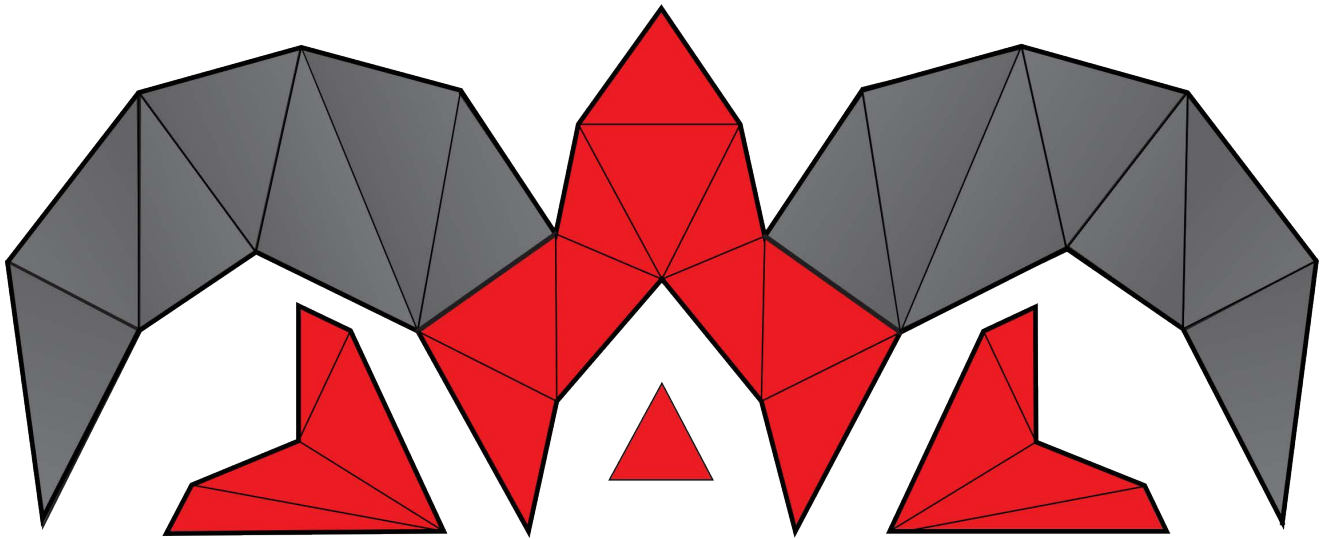

ALL INDUSTRIAL



Motoare certificate ATEX

Certificarea ATEX este destinata pietei europene. Certificarea ATEX, care inseamna ATmosphères EXplosibles (ATmosfere EXplozive), este obligatorie pentru toate produsele instalate in medii potential explozive din statele membre ale Uniunii Europene.

Atex certified motors

Atex is intended for the European market. All products installed in environments at risk of explosion in European Union member states must have ATEX certification, which is an acronym for ATmosphères EXplosibles

2. Referinte de reglementare si certificari

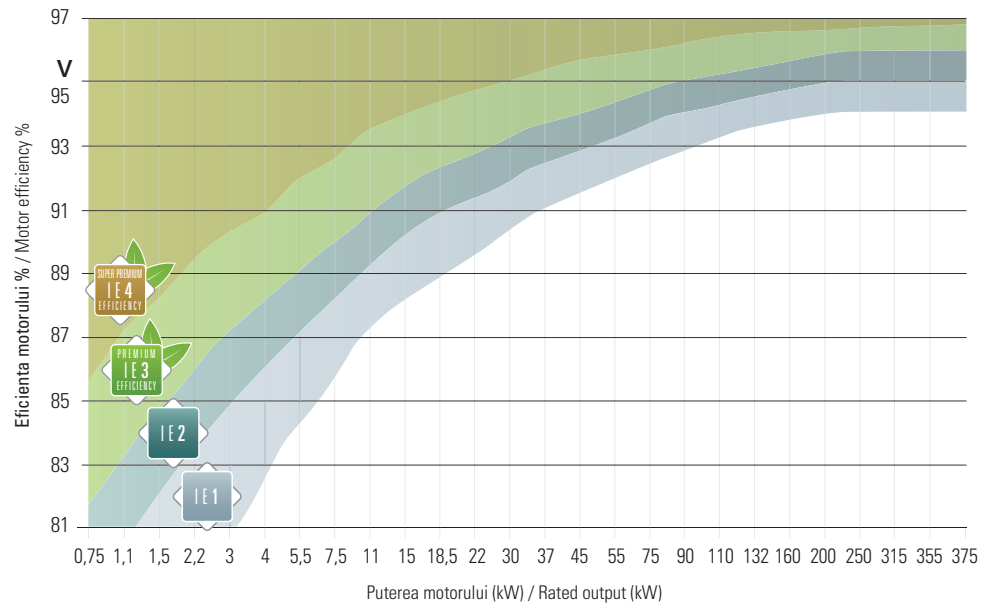

◆ 2.3 Economii si eficienta energetica

Sistemele de automatizare care stau la baza productiei industriale reprezinta aproximativ 45% din consumul global de energie electrica; motoarele electrice sunt responsabile pentru aproximativ 70% din consumul de energie electrica din sectorul industrial al Uniunii Europene: o eficienta energetica sporita a motoarelor ar duce la economii de costuri si la o reducere a emisiilor de CO₂.

Utilizarea motoarelor electrice eficiente inseamna:

- ◆ Reducerea supraincalzirii motorului si, prin urmare, cresterea duratei de viata a izolatiei, rulmentilor si a altor componente ale motorului
- ◆ Avantajele aplicatiilor care necesita invertorul
- ◆ Mai putin zgomot
- ◆ Rezistenta mai mare la suprasarcini si supratensiuni

Reglementari internationale care determina performanta In urma unui acord voluntar intre Asociatia Europeana a Producatorilor de Masini Electrice (CEMEP) si Comisia Europeana, motoarele electrice trifazate de joasa tensiune au fost impartite in clase de eficienta recunoscute la nivel international. Desi diverse tari continua sa utilizeze propriile criterii specifice, standardul international **IEC 60034-30:2008** a stabilit o baza comuna pentru proiectarea si clasificarea motoarelor electrice. Standardul **IEC 60034-2-1:2007** a identificat procedurile de masurare a eficientei motoarelor electrice, definind clasele de eficienta IE1, IE2, IE3 si IE4.

Energy savings and efficiency

Automation systems at the core of industrial production are responsible for approximately 45% of the world's electrical energy consumption; electric motors alone are responsible for about 70% of the electricity used in the industrial sector in the European Community: increased motor energy efficiency would lead to economic savings and a reduction in CO₂ production.

The use of efficient electric motors would ensure:

- ◆ Reduction in motor overheating and therefore longer lasting insulation, bearings and other motor components
- ◆ Advantages in applications that require an inverter
- ◆ Less noise
- ◆ Improved resistance against power surges and voltage fluctuations

International efficiency standards

Following a voluntary agreement between the European committee of manufacturers of electrical machines (CEMEP) and the European Commission, three-phase low voltage motors have been subdivided into efficiency classes recognised at an international level. Although today different countries use their own specific criteria, the international standard **IEC 60034-30:2008** has defined a common base for the design and classification of electric motors. Standard **IEC 60034-2-1:2007** has identified procedures to measure electric motor efficiency, defining efficiency classes IE1, IE2, IE3 and IE4.

◆ 2.4 Domenii de aplicare

Regulamentul European nr. 4/2014

Standardul se aplica la: Motoare trifazate cu inductie tip colivie, cu o singura viteza, cu 2, 4 si 6 poli, putere nominala intre 0,75 si 375 kW, tensiune ≤ 1000 V, frecventa 50 Hz si 60 Hz, alimentate de la retea, regim continuu S1 sau S3 cu regim ciclic ≥ 80%. Toate tipurile de montare, capete de arbore si accesorii; toate nivelurile de protectie de la IP1x la IP6x si toate tipurile de ventilatie de la IC0xx la IC4xx.

Nu se aplica la:

- ◆ Motoare concepute sa functioneze complet imersate intr-un lichid
- ◆ Motoare complet integrate intr-un alt produs (rotor/stator)
- ◆ Motoare conforme cu regulamentul ATEX 2014/34/UE (fosta 94/9/CE)
- ◆ Motoare cu frana
- ◆ Motoare concepute sa functioneze in urmatoarele conditii:
 - Altitudine > 4000 m
 - Temperatura aerului ambiant > 60°C
 - Temperatura maxima de functionare > 400°C
 - Temperatura aerului ambiant < -30°C (motoare racite cu aer) sau < 0°C (motoare racite cu lichid)
 - Temperatura agentului de racire la intrarea in produs sub 0°C sau peste 32°C

Fields of application

European Regulation No. 4/2014

The standard is applied to:

Caged three-phase induction single speed motors with 2, 4 and 6 poles, with rated output between 0.75 and 375kW, voltage ≤ 1000 V, frequency 50 Hz and 60 Hz, in the distribution network, with continuous duty S1 or S3 with intermittence ≥ 80%. All types of fixing, shaft ends, accessories; all levels of protection from IP1x to IP6x and all type of cooling IC0xx to IC4xx.

It does not apply to:

- ◆ Motors designed to work completely submerged in a liquid
- ◆ Motors completely integrated into another product (rotor/stator)
- ◆ Motors compliant with the standard ATEX 2014/34/EU (ex 94/9/EC)
- ◆ Brake motors
- ◆ Motors designed to work in the following conditions:
 - Altitude > 4000 m
 - Environmental air temperature > 60 °C
 - Maximum operating temperature > 400 °C
 - Environmental air temperature < -30 °C (air cooled motors) or < 0 °C (liquid cooled)
 - Temperature of incoming water coolant less than 0 °C or higher than 32 °C

◆ 2.5 Calendar de reglementare

FAZA 1: Introduasa la 16 iunie 2011: Clasa de eficienta minima IE2 pentru motoare cu putere de la 0,75 kW (inclusiv) si mai mare

FAZA 2: Introduasa la 1 ianuarie 2015: Clasa de eficienta minima IE3 pentru motoare cu putere de la 7,5 kW (inclusiv) pana la 375 kW sau IE2 daca motorul este alimentat de inverter

FAZA 3: Introduasa la 1 ianuarie 2017: Clasa de eficienta minima IE3 pentru motoare cu putere de la 0,75 kW (inclusiv) pana la 375 kW sau IE2 daca motorul este alimentat de inverter

Timeline of standards

- STEP 1:** Introduced on 16th June 2011: minimum efficiency class IE2 for motors with output 0.75 kW (inclusive) and higher
- STEP 2:** Introduced on 1st January 2015: minimum efficiency class IE3 for motors with output from 7.5kW (inclusive) to 375 kW or IE2 for inverter controlled motors
- STEP 3:** Introduced on 1st January 2017: minimum efficiency class IE3 for motors with output from 0.75 kW (inclusive) to 375 kW or IE2 for inverter controlled motors









◆ 2.6 Corespondenta dintre reglementarile internationale Comparison of international standards









IEC 60034-30	EU MEPS	CEMEP	US EPAct	alte / others
IE3 Premium efficiency	IE3 Eficienta premium		Eficienta NEMA Premium	
IE2 High efficiency	IE2 Eficienta ridicata	comparabil cu EFF1 <i>comparable to EFF1</i>	Eficienta energetica NEMA / EPACT	CAN/MEX/AUS/NZL/BRA 2009/ CINA 2011 / CH 2012
IE1 Standard efficiency		comparabil cu EFF2 <i>comparable to EFF2</i>		CINA/BRA/Costa Rica/ISR/ Taiwan / CH 2010

(tab. 2)

◆ 2.7 Valori minime de eficienta stabilite de IEC 60034-30-1: 2014

Minimum efficiency values established by standard IEC 60034-30-1: 2014

50Hz	2p= 2			2p= 4			2p= 6		
	IE1  Standard	IE2  High	IE3  Premium	IE1  Standard	IE2  High	IE3  Premium	IE1  Standard	IE2  High	IE3  Premium
kW									
0,75	72,1	77,4	80,7	72,1	79,6	82,5	70	75,9	78,9
1,1	75	79,6	82,7	75	81,4	84,1	72,9	78,1	81
1,5	77,2	81,3	84,2	77,2	82,8	85,3	75,2	79,8	82,5
2,2	79,7	83,2	85,9	79,7	84,3	86,7	77,7	81,8	84,3
3	81,5	84,6	87,1	81,5	85,5	87,7	79,7	83,3	85,6
4	83,1	85,8	88,1	83,1	86,6	88,6	81,4	84,6	86,8
5,5	84,7	87	89,2	84,7	87,7	89,6	83,1	86	88
7,5	86	88,1	90,1	86	88,7	90,4	84,7	87,2	89,1
11	87,6	89,4	91,2	87,6	89,8	91,4	86,4	88,7	90,3
15	88,7	90,3	91,9	88,7	90,6	92,1	87,7	89,7	91,2
18,5	89,3	90,9	92,4	89,3	91,2	92,6	88,6	90,4	91,7
22	89,9	91,3	92,7	89,9	91,6	93	89,2	90,9	92,2
30	90,7	92	93,3	90,7	92,3	93,6	90,2	91,7	92,9
37	91,2	92,5	93,7	91,2	92,7	93,9	90,8	92,2	93,3
45	91,7	92,9	94	91,7	93,1	94,2	91,4	92,7	93,7
55	92,1	93,2	94,3	92,1	93,5	94,6	91,9	93,1	94,1
75	92,7	93,8	94,7	92,7	94	95	92,6	93,7	94,6
90	93	94,1	95	93	94,2	95,2	92,9	94	94,9
110	93,3	94,3	95,2	93,3	94,5	95,4	93,3	94,3	95,1
132	93,5	94,6	95,4	93,5	94,7	95,6	93,5	94,6	95,4
160	93,8	94,8	95,6	93,8	94,9	95,8	93,8	94,8	95,6
200-375	94	95	95,8	94	95,1	96	94	95	95,8

60Hz	2p= 2			2p= 4			2p= 6		
	IE1  Standard	IE2  High	IE3  Premium	IE1  Standard	IE2  High	IE3  Premium	IE1  Standard	IE2  High	IE3  Premium
kW									
0,75	77	75,5	77	78	82,5	85,5	73	80	82,5
1,1	78,5	82,5	84	79	84	86,5	75	85,5	87,5
1,5	81	84	85,5	81,5	84	86,5	77	86,5	88,5
2,2	81,5	85,5	86,5	83	87,5	89,5	78,5	87,5	89,5
3,7	84,5	87,5	88,5	85	87,5	89,5	83,5	87,5	89,5
5,5	86	88,5	89,5	87	89,5	91,7	85	89,5	91
7,5	87,5	89,5	90,2	87,5	89,5	91,7	86	89,5	91
11	87,5	90,2	91	88,5	91	92,4	89	90,2	91,7
15	88,5	90,2	91	89,5	91	93	89,5	90,2	91,7
18,5	89,5	91	91,7	90,5	92,4	93,6	90,2	91,7	93
22	89,5	91	91,7	91	92,4	93,6	91	91,7	93
30	90,2	91,7	92,4	91,7	93	94,1	91,7	93	94,1
37	91,5	92,4	93	92,4	93	94,5	91,7	93	94,1
45	91,7	93	93,6	93	93,6	95	91,7	93,6	94,5
55	92,4	93	93,6	93	94,1	95,4	92,1	93,6	94,5
75	93	93,6	94,1	93,2	94,5	95,4	93	94,1	95
90	93	94,5	95	93,2	94,5	95,4	93	94,1	95
110	93	94,5	95	93,5	95	95,8	94,1	95	95,8
150	94,1	95	95,4	94,5	95	96,2	94,1	95	95,8
185-375	94,1	95,4	95,8	94,5	95,4	96,2	94,1	95	95,8

(tab. 3)

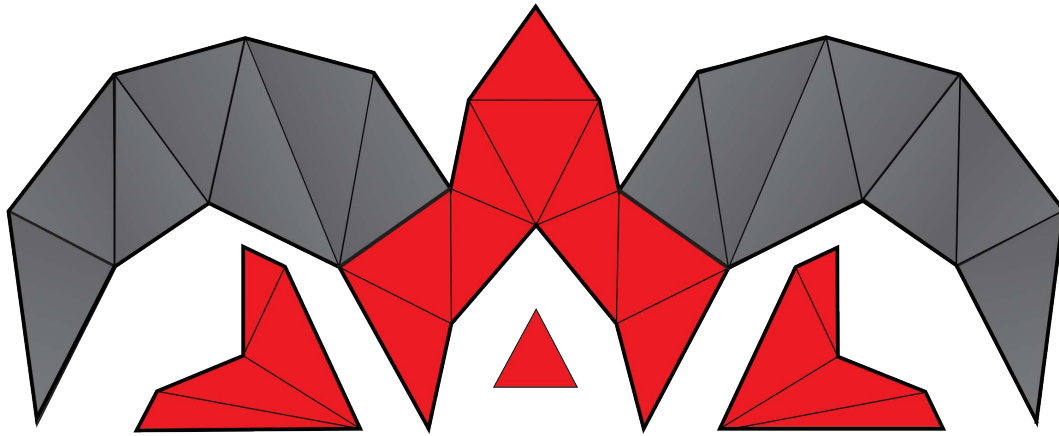

ALL INDUSTRIAL

3.0 Caracteristici generale General specifications

Acest catalog contine descrierea si principalele date tehnice ale motoarelor electrice asincrone trifazate si monofazate standardizate de joasa tensiune, cu rotor in colivie, complet inchise, autoventilate (conform IC 411), cu sau fara frana. Seria trifazata include: 18 dimensiuni de cadru (56÷450) cu o singura viteza de rotatie (2, 4, 6 sau 8 poli); 12 dimensiuni de cadru (71÷280) cu doua viteze (2/4, 4/8, 4/6 sau 6/8 poli). Seria monofazata include 7 dimensiuni de cadru (56÷112) cu o singura viteza de rotatie (2 sau 4 poli).

Caracteristicile generale ale motoarelor sunt urmatoarele:

- ◆ Tensiune standard:
 - 230V/400V +/- 10% 50Hz pentru motoare trifazate 56÷100 cu 2, 4, 6 si 8 poli
 - 400V +/- 10% 50Hz pentru motoare trifazate 100÷450 cu 2, 4, 6 si 8 poli
 - 230V +/- 5% 50Hz pentru motoare monofazate cu 2 si 4 poli
 - Temperatura ambianta de functionare: -20°C pana la +40°C (versiunea standard)
- ◆ Calitate inalta a constructiei
- ◆ Eficienta ridicata (η) si factor de putere ($\cos\varphi$) ridicat
- ◆ Nivel de zgomot mult sub valorile definite de standardele IEC 60034-9
- ◆ Clasa de izolatie F, cu protectie la supraincalzire clasa B
- ◆ Functionare sigura
- ◆ Intretinere simplificata
- ◆ Personalizare rapida

This catalogue contains a description and the main technical specifications of standardised asynchronous three-phase and single phase electric motors in low voltage, with squirrel caged rotor, totally enclosed and fan cooled (as per IC 411), with or without brake. The three-phase series includes: 18 axis heights (56÷450) with single speed rotation (2, 4, 6 or 8 poles); 12 heights (71÷280) with double speed (2/4, 4/8, 4/6 or 6/8 poles). The single phase series includes 7 axis heights (56÷112) with single speed rotation (2 or 4 poles).

The general specifications of motors are as follows:

- ◆ Standard voltage:
 - 230V/Y400V +/-10% 50Hz for three-phase motors, 56÷100 at 2, 4, 6, 8 poles
 - 400V +/-10% 50Hz for three-phase motors 100÷450 at 2, 4, 6, 8 poles
 - 230V +/-5% 50Hz for single phase motors 2, 4 poles
 - Environmental operating temperature from -20°C to +40°C (standard version)
- ◆ High quality construction
- ◆ High efficiency η and high power factor $\cos\varphi$
- ◆ Noise levels well below values defined by IEC EN 60034-9
- ◆ Insulation class F, with overheating class B
- ◆ Safety in duty
- ◆ Simplified maintenance
- ◆ High possibility for personalisation

3. Caracteristici generale

◆ 3.1 Cheia pentru citirea codului de identificare *Reading key and identification code*

Motor / Motor

6TS	112M	4	kW4	230/400V-50Hz	B35	F400	SV3
Serie <i>Series</i>	Dimensiune <i>Size</i>	Numar de poli <i>Number of poles</i>	Putere nominala <i>Nominal output</i>	Sursa de alimentare <i>Main power supply</i> vezi „Anexa” Diagrame de conectare <i>See 'Appendix' Connection diagrams</i>	Configurare <i>Configuration</i> Sectiunea "Configuratii si aranjamente de montare" <i>section 'Configurations and mounting arrangements"</i>	Alimentarea cu energie a franei <i>Brake power supply</i> In mod standard, este SEPARAT de sursa de alimentare a motorului, cu un bloc de conexiuni liber („mammoth”) sau cu un bloc de conexiuni dedicat (doar 1TC). <i>standard is SEPARATED from motor supply, with 'mammoth' connectors, or with dedicated terminal board (only 1TC)</i> Frane de curent continuu S, K, H si R: <i>direct current brakes S, K, H and R:</i> F400 sursa de alimentare redresor 400V 50Hz (2 fire) <i>rectifier power supply 400V 50Hz (2 wires)</i> F230 sursa de alimentare redresor monofazat 230V50Hz <i>single phase rectifier power supply 230V50Hz</i> <hr/> frane de curent alternativ C <i>alternate current brakes C</i> F400 alimentarea trifazata a franei 400V 50Hz <i>three-phase brake power supply 400V 50Hz</i>	Executii speciale <i>Special designs</i> sectiune „Executii speciale” <i>section 'Special designs"</i>

Construcție <i>Construction</i>	Tipul motorului <i>Type of motor</i>	Tip de frana <i>Type of brake</i>	Eficienta <i>Efficiency</i>
6 - Carcasa din aluminiu <i>Aluminium frame</i>	T - Trifazat <i>T - Three-phase</i>	S - frana compacta de curent continuu <i>S - direct current compact brake</i>	1
1 - Carcasa din aluminiu cu scuturi din fonta <i>Aluminium frame cast iron endshields</i>	V - Pereche patrata cu polaritate dubla <i>V - Double speed quadratic torque</i>	K - frana de curent continuu cu cuplu ridicat <i>K - direct current high torque brake</i>	2
7 - Carcasa din fonta <i>Cast iron frame</i>	P - Cuplu constant cu dubla polaritate <i>P - Double speed constant torque</i>	R - frana de curent continuu pozitiv <i>R - direct current positive brake</i>	3
	M - Condensator unic monofazat <i>M - Single phase single capacitor</i>	H - frana dubla de curent continuu pentru teatre <i>H - direct current double brake for theatres</i>	4
	L - Monofazat cu intrerupator centrifugal <i>L - Single phase with centrifugal switch</i>	C - frana de curent alternativ cu cuplu ridicat <i>C - alternate current high torque brake</i>	

SERIE	DESCRIERE	DESCRIPTION	DIMENSIUNI / SIZES
6T1	IE1 trifazat 	Three-phase IE1 	56 - 132
6T2	IE2 trifazat 	Three-phase IE2 	71 - 132
6T3	IE3 trifazat 	Three-phase IE3 	71 - 132
6P	Cuplu constant cu dubla polaritate	Double speed constant torque	71 - 132
6V	Pereche patrata cu polaritate dubla	Double speed quadratic torque	71 - 132
6M	Condensator unic monofazat	Single phase single capacitor	56 - 100
6L	Cuplu de pornire ridicat monofazat	Single phase high starting torque	71 - 112
6TS	Autofranare compacta de curent continuu	DC brake motor compact	63 - 132
6TK	Autofranare de curent continuu cu cuplu ridicat	DC brake motor high torque	63 - 132
6TR	Autofranare pozitiva in curent continuu	DC brake motor positive	63 - 132
6TH	Autofranare dubla de curent continuu pentru cinematografe	DC brake motor double for theatres	90 - 132
6TC	Autofranare AC cu cuplu ridicat	AC brake motor high torque	63 - 132
1TK	Autofranare de curent continuu cu cuplu ridicat	DC brake motor high torque	71 - 132
1TC	Autofranare AC cu cuplu ridicat	AC brake motor high torque	71 - 132
6MS	CC monofazat compact cu autofranare	Single phase motor DC brake compact	63 - 112
6MK	Cuplu ridicat de curent continuu cu autofranare monofazata	Single phase motor DC brake high torque	63 - 112
7T1	IE1 	IE1 	132 - 450
7T2	IE2 	IE2 	132 - 400
7T3	IE3 	IE3 	132 - 400
7P	Cuplu constant cu dubla polaritate	Double speed constant torque	132 - 315
7V	Pereche patrata cu polaritate dubla	Double speed quadratic torque	132 - 315
7TS	Autofranare compacta de curent continuu	DC brake motor compact	132 - 200
7TK	Autofranare de curent continuu cu cuplu ridicat	DC brake motor high torque	132 - 280
7TR	Autofranare pozitiva în curent continuu	DC brake motor high positive	132 - 200
7TH	Autofranare dubla de curent continuu pentru cinematografe	DC brake motor double for theatres	160 - 180
7TC	Autofranare AC cu cuplu ridicat	AC brake motor high torque	132 - 280
TM	Motor conform standardelor UL-CSA	Motor complies with UL-CSA standards	56 - 355

(tab. 4)

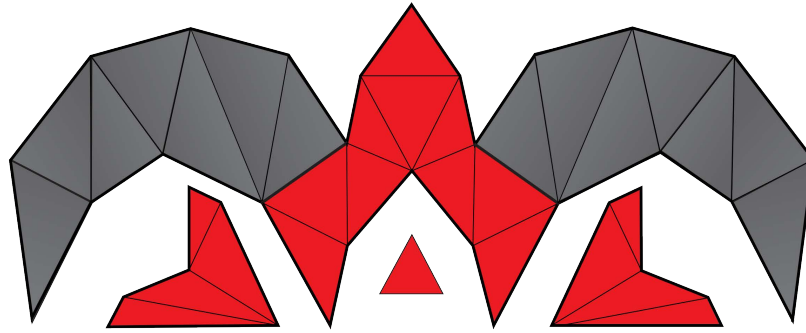

ALL INDUSTRIAL

3.2 Marcare

Markings

Nivelul de eficiența și clasa IE (Eficiența Internațională) sunt indicate pe placuța de identificare și în documentația produsului. Placuțele de identificare ale motoarelor IE3 prezintă datele tehnice cu valorile minime de eficiență la o sarcină de 100%, 75% și 50%, anul de fabricație al motorului și rulmentii utilizați. Din motive de spațiu, eficiențele de 75% și 50% pot fi omise.



The level of efficiency and relative IE class (International Efficiency) are shown on the plate and in the product documentation. IE3 motor plates indicate the technical specifications with minimum efficiency values at 100%, at 75% and at 50% of the load, the year the motor was manufactured and the bearings used. For purposes of space, 75% and 50% efficiencies can be omitted.

- 1- Codul motorului
- 2- Numarul de serie
- 3- Anul fabricatiei
- 4- Factorul de putere
- 5- Tipul de functionare
- 6- Clasa de izolare
- 7- Indicele de protectie fizica
- 8- Greutate

- 9- Clasa de eficiența
- 10- Eficiența la 100%, 75%, 50% sarcina
- 11- Putere motor
- 12- Tensiune nominala
- 13- Frecvența
- 14- Absorbție
- 15- Viteza de rotație
- 16- Tip de rulmenti

- 1- Motor code
- 2- Serial number
- 3- Year of manufacture
- 4- Power factor
- 5- Type of duty
- 6- Insulation class
- 7- Physical protection index
- 8- Weight

- 9- Efficiency class
- 10- Efficiency at 100%,75%, 50% load
- 11- Motor output
- 12- Rated voltage
- 13- Frequency
- 14- Absorption
- 15- Rotating speed
- 16- Type of bearings

		aLlindustrial.Ro		IEC 60034-1	
Type 1	~ N° 2		2017 3		
cosφ 4	I.Cl. 6	IP 7	S 5	kg 8	
⊕ Hz - IE 9 - 10 % (100%) ⊕					
Brake		Nm		V	
Hz 13	V 12	kW 11	A 14	rpm 15	
BRG DE 16		C3		BRG NDE 16 C3	

Symbolism / Symbols

Nume / Nomenclature	Unitate de masura / Unit of measure	Dimensiune / Size
Putere minima / Minimal output	kW, hp	P _N
Viteza nominala / Nominal speed	rpm	n _N
Performanta / Efficiency	%	n
Factor de putere / Power factor	—	cosφ
Curent de aprindere / Starting current	A	I _s
Curent nominal / Nominal current	A	I _N
Cuplu de pornire / Starting torque	Nm	C _m
Cuplu maxim / Maximum torque	Nm	C _{MAX}
Cuplu nominal / Nominal torque	Nm	C _n
Voltaj / Voltage	V	V

◆ 3.3 Forme de constructie si amplasare

Standardul IEC 60034-7 ofera doua modalitati alternative de definire a formei constructive (pozitiei de montare) a unui motor electric: prima este identificata prin literele IM (International Mounting - Montare Internationala) urmate de o alta litera (B = arbore orizontal; V = arbore vertical) si un numar; a doua este un cod mai general compus din literele IM si patru cifre.

Configurations and mounting arrangements

Standard IEC 60034-7 sets forth two different ways of defining the configuration (mounting arrangement) of an electric motor: the first is identified by the letters IM (International Mounting) followed by another letter (B = horizontal shaft; V = vertical shaft) and by a number; the second is a more generic code composed of the letters IM and four numbers.

Forme de constructie / Mounting arrangements

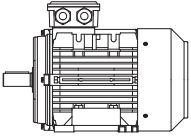
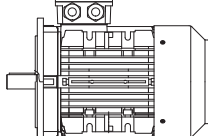
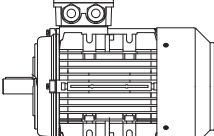
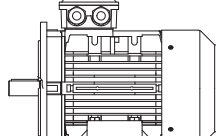
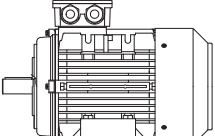
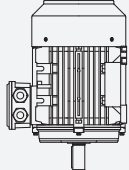
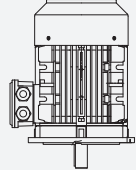
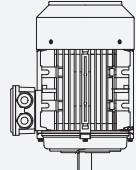
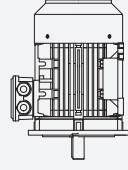
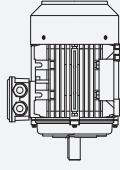
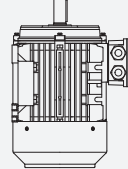
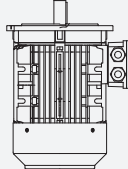
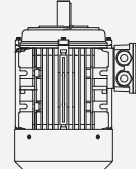
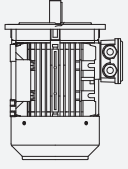
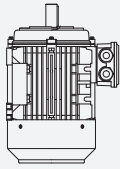
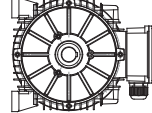
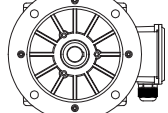
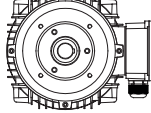
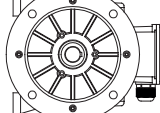
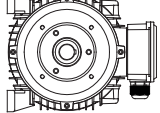
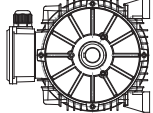
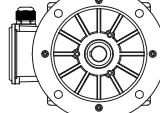
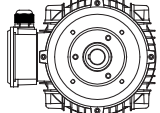
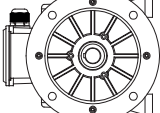
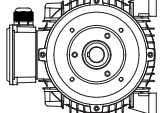
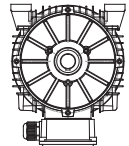
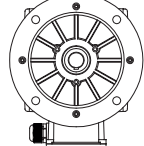
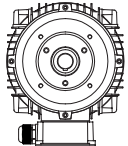
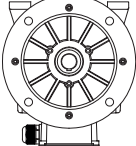
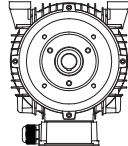
	IM 1001 (IM B3) 	IM 3001 (IM B5) 	IM 3601 (IM B14) 	IM 2001 (IM B35) 	IM 2101 (IM B34) 
DEPLASARE VERTICALA VERTICAL DISPLACEMENT	IM 1011 (IM V5) 	IM 3011 (IM V1) 	IM 3611 (IM V18) 	IM 2011 (IM V15) 	IM 2111 (IM V58) 
	IM 1031 (IM V6) 	IM 3031 (IM V3) 	IM 3631 (IM V19) 	IM 2031 (IM V36) 	IM 2131 (IM V69) 
	IM 1051 (IM B6) 	IM 3051 	IM 3651 	IM 2051 	IM 2151 
	IM 1061 (IM B7) 	IM 3061 	IM 3661 	IM 2061 	IM 2161 
	IM 1071 (IM B8) 	IM 3071 	IM 3671 	IM 2071 	IM 2171 

(tab. 5)

◆ 3.4 Dimensiunile cuplajului arbore-flansa principal conform IEC 60072-1
Main Shaft-Flange coupling dimensions as per IEC 60072-1

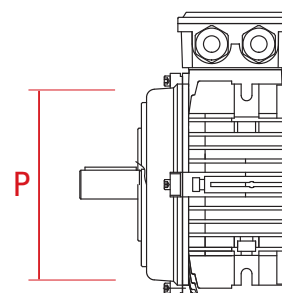
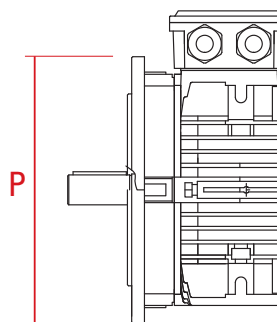
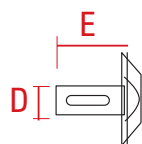

MEC	Poli / Poles	Arbore / Shaft D x E		P		P	
		STD	RID	B5	B5/R	B14	B14/G
56	2-4-6-8	9x20		120		80	
63	2-4-6-8	11x23	9x20	140	120	90	120
71	2-4-6-8	14x30	11x23	160	140	105	140
80	2-4-6-8	19x40	14x30	200	160	120	160
90	2-4-6-8	24x50	19x40	200	160	140	160
100	2-4-6-8	28x60	24x50	250	200	160	200
112	2-4-6-8	28x60	24x50	250	200	160	200
132	2-4-6-8	38x80	28x60	300	250	200	250
160	2-4-6-8	42x110	38x80	350		250	
180	2-4-6-8	48x110	42x110	350			
200	2-4-6-8	55x110	48x110	400			
225	2	55x110		450			
	4-6-8	60x140		450			
250	2	60x140		550			
	4-6-8	65x140		550			
280	2	65x140		550			
	4-6-8	75x140		550			
315	2	65x140		660			
	4-6-8	80x170		660			
355	2	75x140		800			
	4-6-8	100x210		800			
400	2	85x170		1000			
	4-6-8	120x210		1000			
450	2	95x170		1150			
	4-6-8	130x210		1150			

- ☐ Flansa B5 de la MEC 225 inclus si versiunile ulterioare are 8 gauri de fixare;
☐ Flansa B14 de la MEC 71 inclus si versiunile ulterioare are 8 gauri de fixare.

The B5 flange, from MEC 225 included and above, has 8 bolt holes;
The B14 flange, from MEC 71 included and below, has 8 bolt holes

(tab. 6)

◆ 3.5 Materiale si componente / Materials and components

Componente Components	Serie/Serie 6	Serie/Serie 7		Serie/Serie 1
	56-160	132-315	355-450	71-132
carcasa frame	aluminiu aluminum	fonta cast iron	fonta cast iron	aluminiu aluminum
scut si flansa endshield and flange	aluminiu (fonta) aluminum (cast iron)	fonta cast iron	fonta cast iron	fonta cast iron
picioare feet	aluminiu(detasabil) aluminum(removable)	fonta (integrata) cast iron (integrated)	fonta (integrata) cast iron (integrated)	aluminiu (detasabil) aluminum (removable)
capacul ventilatorului fan cover	otel (plastic) steel (plastic)	otel steel	otel steel	otel steel
ventilator fan	termoplastic thermoplastic	termoplastic thermoplastic	aluminiu aluminum	termoplastic thermoplastic
cutie de borne terminal box	aluminiu aluminum	fonta cast iron	fonta cast iron	aluminiu aluminum
garnitura de cablu cable gland	termoplastic thermoplastic	termoplastic thermoplastic	termoplastic thermoplastic	termoplastic thermoplastic
plăcuta de identificare plate	aluminiu aluminum	aluminiu aluminum	aluminiu aluminum	aluminiu aluminum
rotor rotor	aluminiu turnat sub presiune die-cast aluminum	aluminiu turnat sub presiune die-cast aluminum	aluminiu turnat sub presiune die-cast aluminum	aluminiu turnat sub presiune die-cast aluminum
arbore shaft	C40/C45	C40/C45	C40/C45	C40/C45

(tab. 7)

Carcasa motorului si cutia de borne sunt fabricate din aliaj de aluminiu turnat sub presiune (standard MEC 56-132) sau fonta (standard MEC 160-450); la unele motoare monofazate, cutia de borne este fabricata din rasina termoplastica.

Motoarele din aluminiu au picioare modulare pentru a schimba cu usurinta forma constructiva sau a roti orientarea cutiei de borne. De la MEC 100 (inclusiv), toate motoarele au inele sau suruburi de ridicare.

Toate motoarele au o borna de impamantare, marcata corespunzator in interiorul cutiei de borne si pe corpul motorului. Arborele motorului este fabricat din otel C40/C45; dimensiunile capatului arborelui si ale canelurii sunt conforme cu standardele IEC 60072-1. Exista o gaura filetata pe capatul de actionare (DE).

Rotorul cu colivie este fabricat din aluminiu turnat sub presiune sau aliaj de aluminiu-siliciu (sililumin) la motoarele monofazate pentru a creste cuplul de pornire. Numarul si unghiul fantelor sunt proiectate pentru a asigura o functionare lina maxima chiar si cu invertoare.

The casing and terminal box of motors are in die-cast aluminium alloy (standard MEC 56-132) or in cast iron (standard MEC 160-450); on certain single phase motors the terminal box is in thermoplastic resin.

Aluminium motors have modular feet to facilitate variations to the configuration or rotate the direction of the terminal box.

From MEC 100 (included) and above, all motors have eyebolts or rings for lifting.

All motors have a grounding clamp clearly indicated inside the terminal box and on the body of the motor.

The motor shaft is in steel C40/C45; the end shaft and key dimensions are compliant with standard IEC 60072-1, the threaded hole is on the drive end (DE).

The squirrel-cage rotor is made of die-cast aluminium or aluminium and silicon alloy (silumin) on single phase motors to increase the starting torque. The number and inclination of slots have been designed to guarantee the most regular operation, even with inverter.

Stator si infasurare

- ◆ Tabla metalica cu proprietati magnetice controlate
- ◆ Numar de fante si forma geometrica adecvate polaritatii motorului, asigurand o functionare lina maxima;
- ◆ Infasurare din cupru emailat de calitate G2 in clasa H, oferind o rezistenta mecanica ridicata si asigurand o rezerva termica adecvata pentru a incetini imbatranirea motorului;
- ◆ Sistem de izolatie clasa F;
- ◆ Toti parametrii electrici sunt testati 100%.

Stator and winding

- ◆ Sheet metal with controlled magnetic properties
- ◆ Number of slots and geometric shape suited to the motor polarity, so as to enable most regular operation;
- ◆ Winding made with level G2 class H enamelled copper, able to guarantee high mechanical resistance and thermal storage able to slow ageing of motor;
- ◆ Class F insulation system;
- ◆ 100% testing of all electrical parameters.

3. Caracteristici generale

Ventilator

Ventilator centrifugal cu palete radiale pentru racire reversibila, montat extern pe arborele cotit pe partea necuplata. Fabricat din material termoplastic armat cu fibra de sticla, potrivit pentru functionarea la temperaturi normale de functionare ale motorului. La cerere, fabricate din aluminiu sau materiale antistatice si autostingatoare.

Capac ventilator

Tabla metalica presata, profilata corespunzator pentru a evita fenomenele de rezonanta si pentru a imbunatati transportul aerului produs de ventilator catre carcasa motorului; grila de admisie a aerului are orificii dimensionate in functie de distanta fata de piesele rotative accesibile, conform cerintelor de siguranta stabilite de standardul UNI EN 294; la cerere, capacul ventilatorului poate fi furnizat din material plastic pentru medii agresive.

Strat de finisare

Stratul de finisaj este acrilic, culoare RAL 5010. La cerere, putem propune diferite nuante sau aplica cicluri speciale de vopsire pentru a proteja motorul impotriva substantelor agresive sau a conditiilor extreme de mediu (vezi Modele Speciale).

Fan

Centrifugal fan with radial blades to allow reversible cooling, externally connected to the non-drive end shaft. Made from thermoplastic material strengthened with fibreglass, suitable for normal operating temperatures. On request, made from aluminium or antistatic and self-extinguishing materials.

Fan cover

Made of galvanised sheet metal, moulded to prevent resonance phenomena and improve the flow of air generated by the fan on the motor casing; the holes of the air transfer grill comply with safety regulations set forth by standard UNI EN 294 in relation to the distance from accessible rotating parts; on request, the fan cover can be made of plastic for aggressive environments.

Finishing coat

The finishing coat is in acrylic, colour RAL 5010. On request, we can propose different shades or apply special paint cycles to protect the motor against aggressive substances or extreme environmental conditions (see Special Designs).

◆ 3.6 Tolerante

Tolerantele caracteristicilor electrice si functionale ale motoarelor electrice conform standardului CEI EN 60034-1 sunt prezentate in tabelul urmator:

Tolerances

The tolerances of the electrical and operating specifications of electric motors as per standard IEC EN 60034-1 are indicated in the following table:

Caracteristica / Specification		Tolerante electrice / Electric tolerances
Performanta / Efficiency	η	- 0,15 (1- η) Pn \leq 50 kW - 0,10 (1- η) Pn > 50 kW
Factor de putere / Power factor	$\cos\phi$	- (1- $\cos\phi$)/6 min 0,02 max 0,07
Glisant / Sliding		$\pm 20\%$ ($\pm 30\%$ per / for Pn < 1kW)
Curentul rotorului blocat / Locked rotor current	I _s	+ 20%
Cuplu cu rotor blocat / Locked rotor torque	C _s	- 15% + 20%
Cuplu maxim / Maximum torque	C _{max}	- 10%
Moment de inertie / Moment of inertia	J	$\pm 10\%$

(tab. 8)

- ◆ Cand o toleranta este specificata doar intr-o singura directie, valoarea este nelimitata in cealalta directie.
- ◆ Valoarea C_s +20% poate fi depasita prin acord prealabil. Cu conditia ca, odata cu aplicarea acestei tolerante, cuplul sa ramana egal cu 1,6 ori C_n conform IEC 60034-1.

- ◆ If a tolerance is specified for one direction only, the value has no limit in the other direction.
- ◆ The value C_s +20% can be exceeded if previously agreed.
- ◆ Provided that by applying this tolerance, the torque remains equal to 1.6 times C_n as per IEC EN 60034-1.

		Tolerante mecanice / Mechanical tolerances
inaltimea axei / axis height	H \leq 250	-0.5mm
	H > 250	-1mm
capatul arborelui / shaft end	ϕ 11 - 28	j6
	ϕ 38 - 48	k6
	$\phi \geq 55$	m6
cheie / key		h9
flansa / flange	$\phi < 250$	j6
	$\phi \geq 250$	h6

(tab. 9)

◆ 3.7 Zgomot

Tabelul prezinta valorile nominale conform standardului de productie pentru nivelul de putere sonora LWA dB(A) si nivelul mediu de presiune sonora LpA* dB(A), valabile pentru motorul in gol si pentru frecvente de putere de 50 Hz.
Pentru frecvente de 60 Hz, cresteti valorile cu 3-4 dB(A).

dimensiunea motorului motor size	2 Poli / 2 Poles		4 Poli / 4 Poles		6 Poli / 6 Poles		8 Poli / 8 Poles	
	L _{WA}	L _{pA}	L _{WA}	L _{pA}	L _{WA}	L _{pA}	L _{WA}	L _{pA}
56	67	58	61	52				
63	70	61	61	52	59	50		
71	73	64	64	55	61	52	59	50
80	76	67	67	58	63	54	61	52
90	77	68	70	61	66	57	65	56
100	78	69	73	64	70	61	68	59
112	83	74	74	65	72	63	70	61
132	86	77	80	71	78	69	73	64
160	84	75	78	69	72	63	68	59
180	88	79	81	72	80	71	71	62
200	88	79	81	72	75	66	69	60
225	88	79	81	72	78	69	73	64
250	88	79	84	75	81	72	73	64
280	87	78	83	74	82	73	79	70
315	94	85	88	79	84	75	82	73
355	99	90	89	80	85	76	86	77

* Media valorilor masurate la 1 m de suprafata exterioara al motorului situat in camp liber si pe un plan reflectorizant.

Sound levels

The table provides the nominal values as per the standard production value of the sound power level LWA dB(A) and mean sound pressure level LpA* dB(A), valid for the unladen motor at a power frequency of 50 Hz.
For frequencies of 60 Hz, increase the values by 3-4 dB(A).

* Mean obtained by measuring values at 1 m from the external surface of the motor standing in a free field on a reflective surface.

(tab. 10)

◆ 3.8 Vibratii

Motoarele sunt echilibrate dinamic cu o semi-pana aplicata la capatul arborelui conform IEC 60034-14 si au standard clasa de vibratii A. Limitele de intensitate a vibratiilor sunt prezentate in tabelul de mai jos.
Motoarele cu clasa de vibratii B pot fi furnizate la cerere.

Vibrations

Motors are dynamically balanced with a half key applied to the shaft end as per standard IEC 60034-14 and standard designs have vibration class A. The limits of intensity of vibrations are reported in the table below.
On request, motors can be supplied with vibration class B.

	Asamblare Assembly	56 ≤ H ≤ 132			132 < H ≤ 280			H > 280		
		Mutare Displacement μm	Viteza Speed mm/s	Accelerare Acceleration m/s ²	Mutare Displacement μm	Viteza Velocity mm/s	Accelerare Acceleration m/s ²	Mutare Displacement μm	Viteza Speed mm/s	Accelerare Acceleration m/s ²
A	Suspensie libera Free suspension	25	1,6	2,5	35	2,2	3,5	45	2,8	4,4
	Montare rigida Rigid mounting	21	1,3	2,0	29	1,8	2,8	37	2,3	3,6
B	Suspensie libera Free suspension	11	0,7	1,1	18	1,1	1,7	29	1,8	2,8
	Montare rigida Rigid mounting				14	0,9	1,4	24	1,5	2,4

Atentie: Un motor echilibrat corect, asa cum este descris in tabelul de mai sus, poate prezenta vibratii anormale atunci cand este instalat in sistem, din cauza diversilor factori (fundatii nepotrivite, reactii din sistemul actionat, fluctuatii de tensiune). Vibratiile pot aparea si din cauza echilibrarii incorecte a maselor rotative ale sistemului; in aceste cazuri, trebuie efectuate verificari asupra tuturor elementelor instalatiei (a se vedea ISO 10816-3).

Attention: a properly balanced motor as described in the table above may manifest anomalous vibrations when installed in-situ due to various factors (inadequate foundations, reactions by driven machine, current ripples). Vibrations may also be caused by the incorrect balancing of driving elements; in this case, all elements of the installation must be inspected (See ISO 10816-3).

(tab. 11)



3. Caracteristici generale

◆ 3.9 Metoda de racire

Motoarele in executie standard de la marimea 56 la 450 sunt caracterizate prin metoda de racire IC 411, cu ventilator radial bidirectional.

Cooling method

Standard motors in sizes from 56 to 450 utilise the IC 411 cooling method with two-way radial fan.

Definitia metodei de racire este data de codul IC (International Cooling), in conformitate cu IEC 60034-6
The cooling method is defined by the IC (International Cooling) code, in accordance with

Cod IC (simplificat) / Code IC (simplified)

IC 4 1 -

Schema circuitului / Circuit layout

Metode de circulatie secundara a agentului de racire.
secondary cooling method.

Metode primare de circulatie a agentului de racire.
Cooling circulation method.

Toate motoarele pot fi furnizate la cerere cu sisteme de racire IC 416. In acest caz, in carcasa ventilatorului va fi instalat un ventilator adecvat, ranforsat corespunzator pentru a face ventilatia independenta de viteza de rotatie. (vezi DESIGNURI SPECIALE)

All motors can be supplied with IC 416 cooling systems on request. In this case, a suitable fan will be installed in the fan cover, properly reinforced to make ventilation independent of the rotation speed. (see SPECIAL DESIGNS)

IC 411

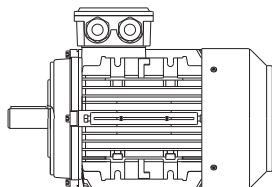

Motor autoventilat. Masina inchisa.
 Ventilator extern montat pe arborele motorului.
*Self-cooling motor. Closed machine.
 External fan mounted on motor shaft.*

construite in serie
standard configuration.

IC 416

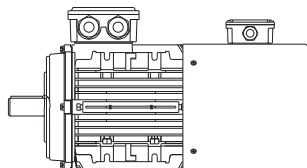

Motor cu ventilatie fortata.
 Masina inchisa, cu aripi externe.
 Ventilator independent montat in interiorul carcasei ventilatorului.
*Motor with assisted cooling.
 Closed machine, externally finned.
 Independent fan mounted inside fan cover.*

la cerere
on request

IC 418

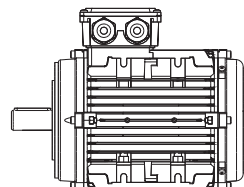

Motor ventilat extern. Masina inchisa. Racirea este asigurata de un dispozitiv care nu este montat pe motor.
*Motor with external cooling. Closed machine.
 Cooling ensured by a device not mounted on the motor.*

la cerere
on request

IC 410

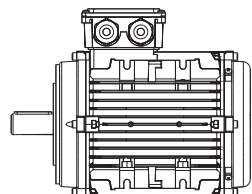

Motor ventilat natural. Masina inchisa.
*Motor with natural cooling.
 Closed machine.*

la cerere
on request

(tab. 12)

◆ 3.10 Grad de protectie IP

Selectarea gradului corect de protectie este esentiala pentru a asigura functionarea optima si de lunga durata a motorului, tinand cont de mediul de lucru. Clasificarea, in conformitate cu standardul IEC EN 60034-5, consta in acronimul IP (International Protection - Protectie Internationala), urmat de o prima cifra (0-6) care determina protectia impotriva contactului si patrunderii obiectelor solide; o a doua cifra (0-8) determina protectia impotriva infiltratiilor de apa.

IP protection level

Choosing the correct protection level is important to ensure excellent and long-lasting motor performance in relation to the workplace conditions. Pursuant to standard IEC EN 60034-5, protection levels are classified by the letters IP (International Protection) followed by a first digit 0-6, which determines the level of protection against contact with and the entry of solid impurities; the second digit 0-8 determines the level of protection against the infiltration of water.

IP 5 5

Prima cifra / First digit

0		Neprotejat <i>Not protected</i>
1		Protejat impotriva corpurilor straine solide cu $\varnothing \geq 50\text{mm}$ <i>Protected against solid foreign impurities $\varnothing \geq 50\text{mm}$</i>
2		Protejat impotriva corpurilor straine solide cu $\varnothing \geq 12,5\text{mm}$ <i>Protected against solid foreign impurities $\varnothing \geq 12.5\text{mm}$</i>
3		Protejat impotriva corpurilor straine solide cu $\varnothing \geq 2,5\text{mm}$ <i>Protected against solid foreign impurities $\varnothing \geq 2.5\text{mm}$</i>
4		Protejat impotriva corpurilor straine solide cu $\varnothing \geq 1,0\text{mm}$ <i>Protected against solid foreign impurities $\varnothing \geq 1.0\text{mm}$</i>
5		Protejat impotriva prafului <i>Protected against dust</i>
6		Fara patrunderea prafului <i>No entry of dust</i>

A doua cifra / Second digit

0		Neprotejat <i>Not protected</i>
1		Protejat impotriva picaturilor de apa care cad pe verticala <i>Protected against vertically falling drops of water</i>
2		Protejat impotriva picaturilor de apa care cad pe verticala la o inclinare de pana la 15° <i>Protected against vertically falling drops of water with an inclination up to 15°</i>
3		Protejat impotriva ploii <i>Protected against rain</i>
4		Protejat impotriva stropilor de apa din toate directiile <i>Protected against spurts of water from all directions</i>
5		Protejat impotriva jeturilor de apa <i>Protected against spurts of water</i>
6		Protejat impotriva jeturilor de apa sub presiune <i>Protected against spurts of pressurised water</i>
7		Protejat impotriva efectelor imersiunii temporare <i>Protected against the effects of temporary immersion</i>
8		Protejat impotriva efectelor imersiunii continue <i>Protected against the effects of continuous immersion</i>

(tab. 13)

3. Caracteristici generale

◆ 3.11 Izolatie si infasurare statorica

Infasurarea statorului are o clasa de izolatie F, desi poate fi realizata si in clasa H la cerere speciala. Infasurarea statorului este realizata din sarma de cupru lacuita cu sectiune rotunda, izolata cu vopsea de inalta calitate. Infasurarea statorului este plasata in fante, impregnata in exteriorul carcusei si introdusa intr-un cuptor. Procesul tehnologic adoptat pentru impregnare si materialele de inalta calitate utilizate asigura: o rezistenta mecanica si dielectrica excelenta a infasurarii, rezistenta la agresiunile mediului si fiabilitate a motorului.

Insulation and stator winding

Insulation system of stator winding is in the thermal class F and on special request motors can be manufactured in class H as well. Stator winding is made of round copper conductors insulated by high quality varnish.

Stator winding is inserted and impregnated outside the frame. High quality materials and adopted technological process of impregnation ensure high mechanical and dielectrical strenght of winding, resistance to the negative effects of environment and reliability of motors.

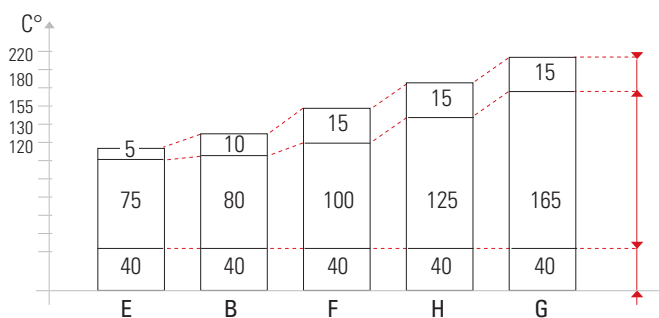

Marja de siguranta
Safety margin

Supratemperatura admisibila
Allowable overtemperature

Temperatura conventionala a camerei 40°C
Conventional environmental temperature 40°C

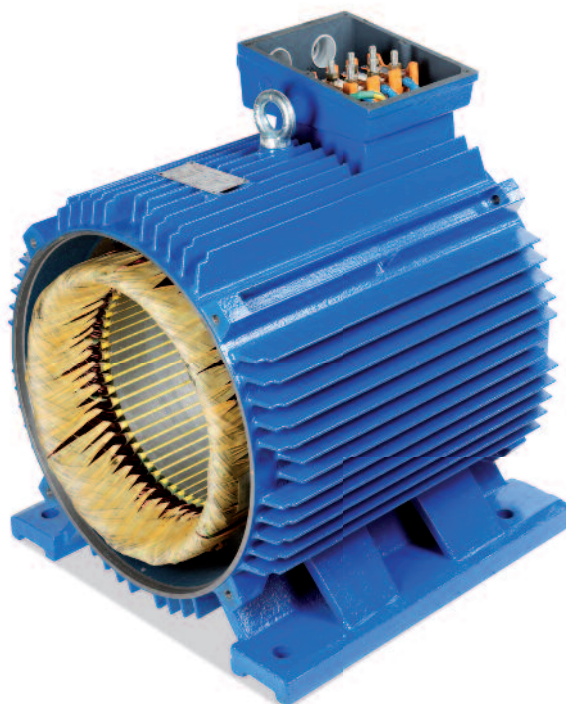
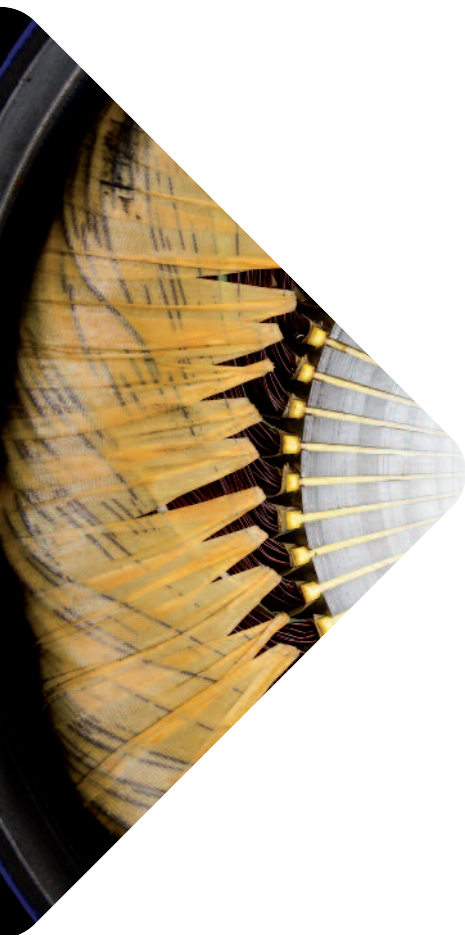

◆ 3.12 Variatia puterii datorata conditiilor de mediu

Daca motorul functioneaza la o temperatura ambientala mai mare de 40°C si/sau la o inaltime deasupra nivelului etansarii mai mare de 1000 m, atunci acesta trebuie declasificat conform tabelului:

Variations of power related to environmental conditions

If the motor works at an environmental temperature higher than 40°C and/or at a height above seal level greater than 1000 m, then it must be declassified as per the table:

Altitudine deasupra nivelului marii (m) Height above sea level (m)		Puteri permise / Allowable output / P / (%) Temperatura camerei °C / Environmental temperature °C				
		0-40	45	50	55	60
pana la / to	1000	100	97	93	88	82
	1500	98	95	91	86	80
	2000	94	91	87	82	77
	2500	91	88	84	80	74
	3000	87	84	81	76	71
	3500	82	79	76	72	67
	4000	77	74	71	67	63

(tab. 14)

◆ 3.13 Modificarea caracteristicilor nominale

Caracteristicile de functionare ale unui motor trifazat alimentat de tensiuni si/sau frecvente altele decat frecventele normale ale infasarilor pot fi obtinute cu o buna aproximare prin inmultirea valorilor nominale cu coeficientii de corectie din tabelul de mai jos.

Variation of nominal specifications

The operating specifications of a three-phase motor powered by voltage and/or frequencies different to nominal ones, can be obtained with good approximation by multiplying the nominal values by the correction coefficients as per the table below.

Sursa de alimentare nominala Nominal supply	Sursa alternativa de alimentare Alternative supply	Factori corectivi / Correction factors								
		Pn	rpm	In	Cn	Is/In	Cs/Cn	Cmax/Cn		
Δ230 Y400V-50Hz	50Hz Δ220 Y380 Δ380	1	1	1	1	0,96	0,9	0,9		
	50Hz Δ240 Y415 Δ415	1	1	1	1	1,04	1,08	1,08		
Δ400V-50Hz	60Hz Δ220 Y380 Δ380	1	1,2	1	0,83	0,79	0,84	0,84		
	60Hz Δ255 Y440 Δ440	1,1	1,2	1,02	0,93	0,92	0,92	0,92		
	60Hz Δ265 Y460 Δ460	1,15	1,2	1	0,95	0,96	0,96	0,96		
	60Hz Δ277 Y480 Δ480	1,2	1,2	1	1	1	1	1		

(tab. 15)

3. Caracteristici generale

◆ 3.14 Tipul de serviciu

Puterea nominala indicata pe placuta de identificare a motorului electric se refera de obicei la utilizarea continua la o sarcina constanta (functionare S1). Toate tipurile de functionare descrise de standardele IEC 60034-1 sunt enumerate mai jos.

S1

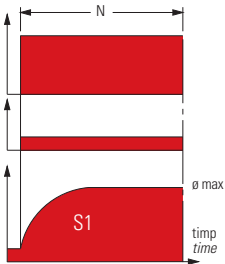

Functionare continua. Functionare la o sarcina constanta pentru o durata suficienta pentru a permite echilibrul termic.

Continuous duty.
Operation with steady load for an indefinite period sufficient to reach a thermal balance.

S4

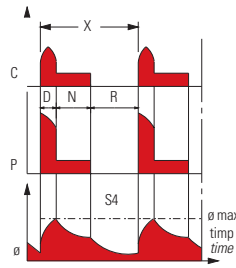

Functionare intermitenta periodica cu pornire.

O secventa de cicluri de functionare identice, fiecare cuprinzand o faza de pornire, o perioada de functionare la sarcina constanta si o perioada de repaus. Echilibrul termic nu este atins in timpul perioadei de sarcina.

Intermittent periodic duty with start-up. Sequence of identical operating cycles, each including a start-up phase, a period of operation with a steady load and a rest period. During the loaded period, a thermal balance is not reached.

$$S4 : [(D+N) / (D+N+R) \times 100\%]$$

S2

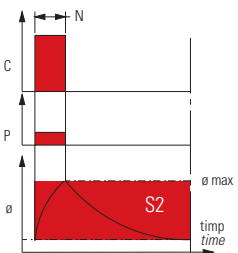

Functionare continua. Functionare la sarcina constanta pentru o perioada de timp mai scurta decat cea necesara pentru echilibrul termic, urmata de o perioada de repaus suficient de lunga pentru a readuce motorul la temperatura ambianta.

Continuous duty.
Duty with a steady load for a shorter period of time than that needed to reach a thermal balance, followed by an indefinite rest period sufficient to bring the motor back to the environmental temperature.

S5

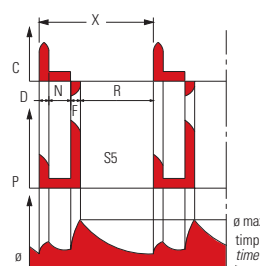

Functionare periodica intermitenta cu franare electrica. O secventa de cicluri de functionare identice, fiecare cuprinzand o faza de pornire, o perioada de functionare la sarcina constanta, o faza de franare electrica rapida si o perioada de repaus. Echilibrul termic nu este atins in timpul perioadei de sarcina.

Intermittent periodic duty with electric brake. Sequence of identical operating cycles, each including a start-up phase, a period of operation with a steady load, a rapid electric brake phase and a rest period. During the loaded period, a thermal balance is not reached.

$$S5 : [(T(D+N+F) / X) \times 100\%]$$

S3

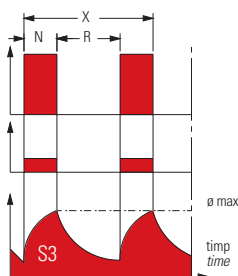

Functionare intermitenta periodica. O secventa de cicluri de functionare identice, fiecare cuprinzand o perioada de functionare la sarcina constanta si o perioada de repaus. Curentul de pornire nu afecteaza temperatura. Echilibrul termic nu este atins in timpul perioadei de sarcina.

Intermittent periodic duty
Sequence of identical operating cycles, each including a start-up phase, a period of operation with a steady load, a rapid electric brake phase and a rest period. During the loaded period, a thermal balance is not reached.

$$S3 : [N / (N+R) \times 100\%]$$

S6

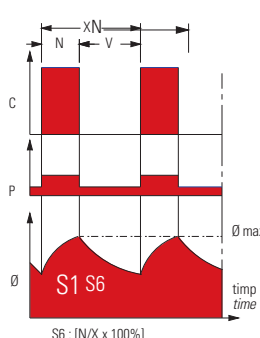

Functionare periodica neintrerupta. O secventa de cicluri de functionare identice, fiecare cuprinzand o perioada de functionare cu sarcina constanta si o perioada de functionare fara sarcina, fara nicio perioada de repaus.

Continuous periodic duty. Sequence of identical operating cycles, each including a start-up phase, a period of operation with a steady load, a rapid electric brake phase and a rest period.

$$S6 : [N/X \times 100\%]$$

S7

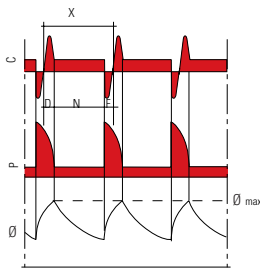

Functionare periodica continua cu franare electrica. O secventa de cicluri de functionare identice, fiecare cuprinzand o faza de pornire, o perioada de functionare la sarcina constanta si o faza de franare electrica rapida fara perioada de repaus. Echilibrul termic nu este atins in timpul perioadei de sarcina.

Continuous periodic duty with electric brake. Sequence of identical operating cycles, each including a start-up phase, a period of operation with a steady load, a rapid electric brake phase without a rest period. During the loaded period, a thermal balance is not reached.

S9

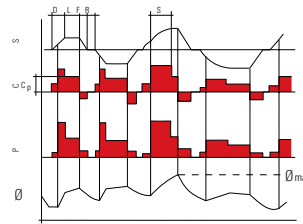

Regim de functionare cu variatii neperiodice ale sarcinii si vitezei. Regim de functionare in care sarcina si viteza variaza neperiodic in intervalul de functionare admis. Acest regim include supraincari aplicate frecvent, care pot fi semnificativ mai mari decat valorile la sarcina maxima.

Duty with non periodic changes in load and speed. Duty whereby the load and speed vary within the allowable operating range, at no specific intervals. This duty includes frequent overloads that may be significantly higher than full load values.

LEGEND

LEGENDA

- | | |
|--|--|
| <i>N:</i> Timp de functionare la sarcina constanta | <i>N:</i> Steady load operating time |
| <i>R:</i> Timp de repaus | <i>R:</i> Rest time |
| <i>D:</i> Timp de pornire | <i>D:</i> Starting time |
| <i>F:</i> Timpul de franare electric | <i>F:</i> Electric brake time |
| <i>V:</i> Timp de functionare fara sarcina | <i>V:</i> No load operating time |
| <i>max:</i> Temperatura maxima in timpul ciclului | <i>max:</i> Maximum temperature during the cycle |
| <i>L:</i> Timp de functionare la sarcini variabile | <i>L:</i> Variable loads operating time |
| <i>Cp:</i> Sarcina maxima | <i>Cp:</i> Full load |
| <i>O:</i> Timp de functionare la suprasarcina | <i>O:</i> Overload operating time |
| <i>X:</i> Timp de ciclu | <i>X:</i> Cycle time |
| <i>S:</i> Viteza | <i>S:</i> Speed |
| <i>Ø:</i> Temperatura | <i>Ø:</i> Temperature |
| <i>P:</i> Pierderi electrice | <i>P:</i> Electrical losses |
| <i>C:</i> Sarcina | <i>C:</i> Load |
| <i>T:</i> Timp | <i>T:</i> Time |

S8

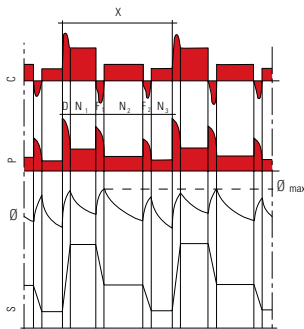

Functionare periodica neintrerupta cu variatii corelate ale sarcinii si vitezei. O secventa de cicluri de functionare identice, constand in perioade de functionare la sarcina constanta de marime variabila, fara nicio perioada de repaus.

Continuous periodic duty with electric brake. Sequence of identical operating cycles, each including a start-up phase, a period of operation with a steady load, a rapid electric brake phase without a rest period. During the loaded period, a thermal balance is not reached.

Serviciile de tip S2 si S3 va permit sa cresteti puterea motorului in comparatie cu S1, asa cum se arata in tabelul de mai jos:

Duty types S2 and S3 can increase the motor output with respect to S1, as per the table below:

Tipul de serviciu / Type of duty	Putere admisa vs. putere in S1 (nr. de ori) / Allowable output with respect to output in S1 (no. of times)	
S2	Durata serviciului / Duration of duty	
	10 min.	1,35
	30 min.	1,15
	60 min.	1,05
S3	Raportul de intermitenta / Intermittence	
	25%	1,25
	40%	1,15
	60%	1,10
S4 ÷ S9	Contacteaza-ne / Contact us	

(tab. 16)

(I) Raportul de intermitenta / Intermittence:

$$I = \frac{N}{N + R} \times 100\%$$

Timpul ciclului in serviciul S3 trebuie sa fie mai mic de 10 minute. Pentru timpi de ciclu mai lungi, va rugam sa ne contactati.

The duration of the cycle in S3 duty must be less than 10 min. For higher durations, contact us.

3. Caracteristici generale

◆ 3.15 *Directia de rotatie*

Motoarele pot functiona in ambele sensuri de rotatie. Prin conectarea bornelor U1, V1 W1 la fazele de linie R, S, T, se obtine rotatia in sensul acelor de ceasornic daca se priveste arborele dinspre capatul cuplajului. Rotatia in sensul invers acelor de ceasornic se obtine prin inversarea celor doua faze.

Direction of rotation

It is possible for motors to operate in both directions of rotation. By connecting terminals U1, V1 W1 to line phases R, S, T, clockwise rotation is obtained if looking at the shaft from the coupling end. Anti-clockwise rotation is obtained by swapping the two phases.

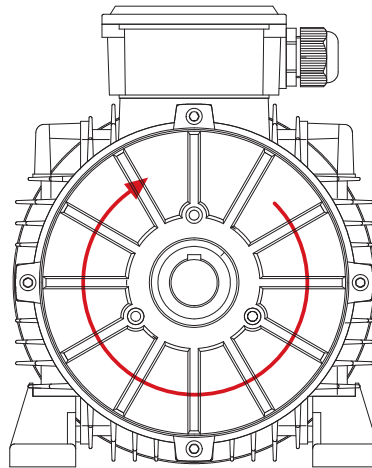

03

◆ 3.16 *Pornire*

Mai jos sunt principalele metode de pornire pentru motoare:

- ◆ Pornire directa
- ◆ Pornire stea-triunghi
- ◆ Pornirea autotransformatorului
- ◆ Pornire usoara (*)
- ◆ Pornire cu inverter (**)

(*) Ocoliti pornirea lina dupa pornire, in caz contrar utilizati aceleasi precautii ca si pentru motorul alimentat de inverter.
(**) Consultati sectiunea „Alimentare cu inverter”.

Starters

Following are the types with which aLLindustrial motors can be started:

- ◆ *Direct starter*
- ◆ *Star - triangle starter*
- ◆ *Autotransformer starter*
- ◆ *Soft-start starter (*)*
- ◆ *Starter with inverter (**)*

(*) *Bypass the soft-start at the end of starting, otherwise use the same techniques as the inverter controlled motor.*
(**) *See the section "Inverter control".*

◆ 3.17 Controlul invertorului

Utilizarea unui motor electric de inalta eficienta combinata cu convertizoare de frecventa (invertoare) permite o optimizare suplimentara a economiilor de energie, adaptand caracteristicile motorului la cerintele reale de sarcina atat in timpul utilizarii normale, cat si la pornire, reducand in acelasi timp solicitarile mecanice asupra tuturor elementelor de transmisie.

Toate motoarele trifazate unipolare sunt potrivite pentru functionarea cu invertoare, datorita adoptarii unor caracteristici constructive specifice, cum ar fi:

- ◆ Sistem excelent de izolatie
- ◆ Utilizarea separatoarelor de faza
- ◆ Infasurare ranforsata a bobinelor de infasurare
- ◆ Impregnarea in vid a infasurarilor
- ◆ Placi cu pierderi reduse
- ◆ Dimensionare electromagnetica generoasa
- ◆ Rotor echilibrat corespunzator pentru a rezista la viteze mari
- ◆ Rulmenti C3 cu vaselina pentru temperaturi ridicate.

Operatiune

Motorul isi variaza viteza de rotatie in functie de frecventa de alimentare, mentinand un raport V/f constant (Fig. 1). Tensiunea de alimentare, extrasa din retea cu o amplitudine si o frecventa fixe, este convertita intr-o tensiune cu amplitudine si frecventa variabile.

Invertorul nu poate genera o tensiune de iesire mai mare decat tensiunea de intrare (tensiunea retelei), dar poate creste frecventa mult peste valoarea retelei (Fig. 2).

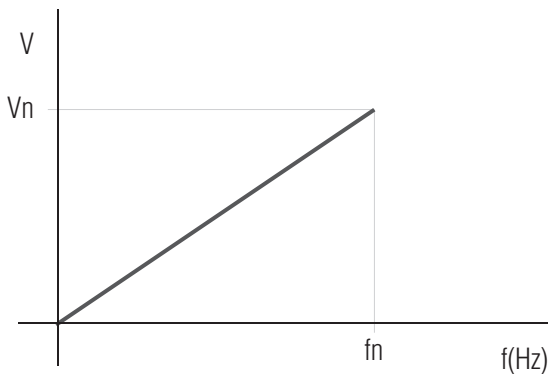

fig. 1

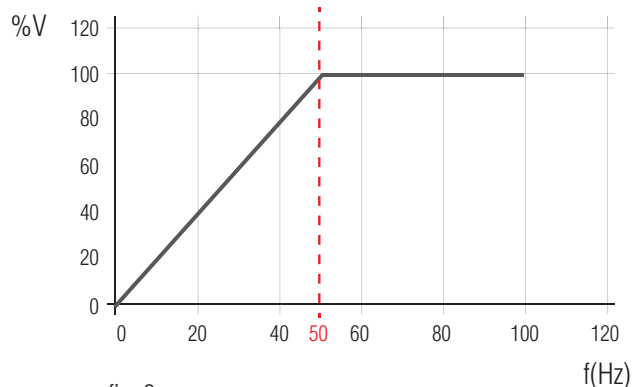

fig. 2

Prin urmare, de la 0 la 50 Hz, debitul creat de infasurarile statorului va fi constant, in timp ce la frecvente mai mari debitul va fi mai mic decat valoarea maxima, afectand in consecinta cuplul motorului. Pentru frecvente de functionare intre 5 si 35 Hz, motoarele trebuie declasate corespunzator in cuplu, deoarece racirea motorului nu va mai fi eficienta. Putem totusi mentine un cuplu constant chiar si sub 50 Hz, prin configurarea motorului cu racire fortata (IC 416).

Urmatoarele grafice fig. 3 si fig. 4 reprezinta valori ale cuplului in functie de frecventa pentru motoarele IC411 si IC416; graficul din fig. 5 indica variatia puterii de iesire ca urmare a frecventei.

Inverter control

Use of a high efficiency electric motor in combination with frequency converters (inverters) allows improved energy savings, adapting the characteristics of the motor to real load needs, both during normal operation and during start-up, while also reducing mechanical stress for all drive elements.

All three-phase single polarity all industrial motors can be operated with inverters thanks to the use of special construction techniques, such as:

- ◆ excellent insulation system
- ◆ use of phase separators
- ◆ reinforced wrapping of winding cores
- ◆ vacuum pressure impregnated windings
- ◆ low loss plates
- ◆ generous electromagnetic sizing
- ◆ rotor suitably balanced to support high speeds
- ◆ C3 bearings with grease for high temperatures.

Operation

The motor adjusts the rotation speed depending on the frequency of the power supply, maintaining a constant V/f ratio (fig.1). The supply voltage, withdrawn from the network with fixed amplitude and frequency, is converted into voltage with variable amplitude and frequency.

In output, the inverter cannot generate a voltage higher than the inbound value (network voltage), but can however increase the frequency well beyond the network value (fig.2).

Therefore, from 0 to 50Hz the flow created by the stator windings will be constant, while at higher frequencies the flow will be less than the maximum value, consequently affecting the motor torque. For operating frequencies between 5 and 35Hz, motors must be suitably declassified in torque insofar as motor cooling will no longer be efficient. We can however maintain a constant torque even below 50Hz, by setting up the motor with forced cooling (IC 416).

The following graphs fig.3 and fig.4 represent torque values depending on frequency for IC411 and IC416 motors; the graph in fig.5 indicates the variation in output as a result of the frequency.

3. Caracteristici generale

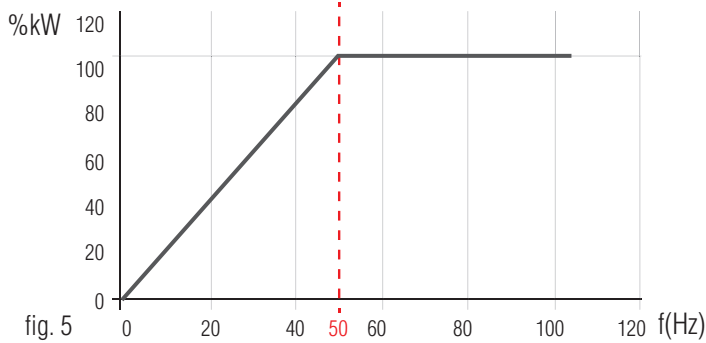
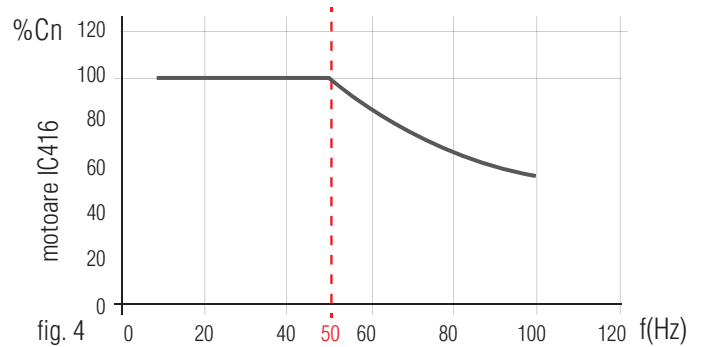
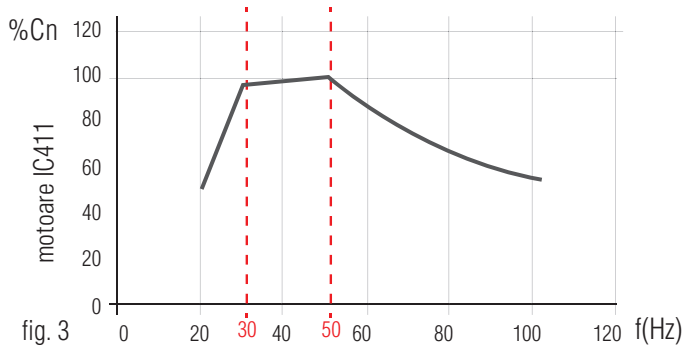

Functionare V/f constanta pana la 87Hz

Prin conectarea in triunghi a motoarelor cu infasurari de 230/400V 50Hz, putem obtine un flux magnetic constant al motorului de pana la 87Hz, rezultand o putere crescuta si o curba de cuplu mai larga (Fig. 6). Invertorul trebuie dimensionat pentru a tine cont de cresterea de putere rezultata.

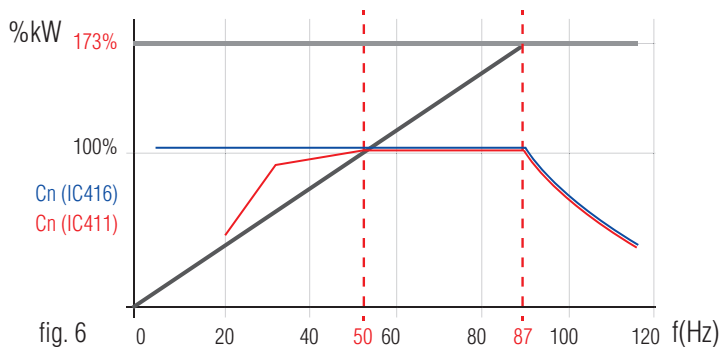

Note generale

Sursele de alimentare cu inverter implica anumiti factori care trebuie luati in considerare:

- ◆ pe masura ce viteza de rotatie a motorului creste, uzura pieselor mecanice si vibratiile cresc si ele; la motoarele autoventilate
- ◆ (IC411) zgomotul creste si el semnificativ
- ◆ tensiunea de alimentare furnizata de inverter nu este pur sinusoidala si provoaca un continut armonic, legat in principal de tipul de inverter, frecventa de comutare si lungimea cablurilor de alimentare; continutul armonic poate fi atenuat folosind filtre speciale.
- ◆ in prezenta mai multor motoare conectate in paralel la acelasi inverter, se recomanda verificarea formei de unda a tensiunii la capetele cablurilor de alimentare
- ◆ motoarele cu autofranare trebuie sa aiba o sursa separata de alimentare a franei pentru a asigura functionarea corecta a electromagnetului de frana

Operation with constant V/f up to 87Hz

By connecting motors with a 230/400V/50Hz winding in delta, we can obtain a constant magnetic flow of the motor up to 87Hz, with a consequent increase in output and extension of the torque curve (fig.6). The inverter will need to be sized in consideration of the following increase in output.

General notes

Inverter control involves certain phenomena that must be duly taken into account:

- ◆ as the motor rotation speed increases, so too does the wear of mechanical parts and vibrations; in self-cooling motors (IC411), sound levels also increase considerably
- ◆ the voltage supplied by the inverter is not purely sinusoidal and causes some harmonic distortion tied mainly to the type of inverter, the value of the switching frequency, the length of power cables; harmonic distortion can be reduced by using special filters
- ◆ if multiple motors are connected in parallel to the same inverter, it is recommended to check the waveform of the voltage at the power cable lugs
- ◆ brake motors must have a separate power supply to the brake, to guarantee the correct operation of the brake electric magnet

◆ 3.18 Sarcini radiale si axiale

Daca legatura dintre motor si masina se realizeaza cu o transmisie care genereaza sarcini radiale pe capatul arborelui, este necesar sa se verifice daca acestea sunt mai mici sau egale cu cele prezentate in tabelul de mai jos. Sarcina radiala se obtine din:

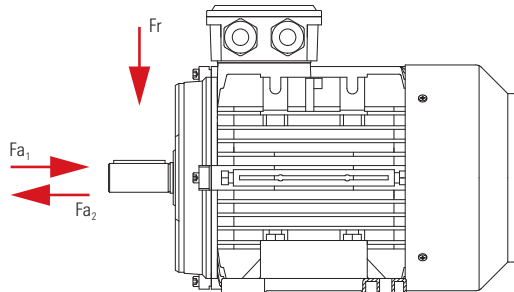

unde:

Pn este puterea necesara motorului (kW)

rpm este viteza unghiulara (min-1)

dp este diametrul initial al rotii sau scripetelui (m)

C este un coeficient care ia o valoare diferita in functie de tipul de transmisie:

C = 1 pentru transmisie cu lant

C = 1,1 pentru transmisie cu angrenaje

C = 1,5 pentru transmisie cu curea dintata

C = 2,5 pentru transmisie cu curea trapezoidala

Tabelul indica valorile maxime admisibile pentru sarcinile radiale si axiale care actioneaza asupra capatului arborelui (de la mijlocul arborelui), calculate pentru o perioada egala cu 2000 de ore. Pentru perioade mai lungi, valorile indicate trebuie inmultite cu coeficientii de corectie corespunzatori.

Radial and axial loads

If the connection between the motor and machine is made using a transmission that generates radial loads on the shaft end, it must be checked whether these are less than or equal to those reported in the table below. The radial load is obtained from:

$$Fr = \frac{C \cdot 19100 \cdot P_n}{rpm \cdot dp} \text{ (N)}$$

where:

Pn is the power required by the motor (kW)

rpm is the angular velocity (min -1)

dp is the primitive diameter of the wheel or pulley (m)

C is a coefficient that assumes a different value depending on the type of drive:

C= 1 for chain drive

C= 1.1 for wheel drive

C= 1.5 for toothed belt drive

C= 2.5 for V-belt drive

The table indicates the maximum allowable values for radial and axial loads that act on the shaft end (From middle of shaft), calculated for a period equal to 2000 hours. For longer periods, the values shown must be multiplied by the relevant correction coefficients.

DIMENSIONE FRAME	Linia centrala Fr(N) a arborelui Fr(N) middle of the shaft				Plasarea orizontala Fa1(N) - Fa2(N) Fa1(N) - Fa2(N) horizontal mounting				Plasarea verticala Fa2(N) Fa2(N) vertical mounting			
	2 POLI POLES	4 POLI POLES	6 POLI POLES	8 POLI POLES	2 POLI POLES	4 POLI POLES	6 POLI POLES	8 POLI POLES	2 POLI POLES	4 POLI POLES	6 POLI POLES	8 POLI POLES
rpm												
56	225	285	-	-	175	225	-	-	135	170	-	-
63	235	300	350	-	180	225	250	-	135	170	200	-
71	360	450	520	550	250	325	360	410	190	270	320	350
80	400	520	600	675	350	475	540	580	320	430	400	540
90	570	740	875	990	375	540	620	650	360	475	540	585
100	770	990	1130	1250	550	750	825	900	500	690	780	860
112	800	1010	1150	1250	550	750	825	900	500	690	780	860
132	1175	1485	1700	1875	900	1250	1330	1450	700	950	1175	1340
160	2050	2610	2950	3275	1300	1580	1925	2140	1035	1375	1725	1950
180	2950	3820	4370	4825	1900	2475	3050	3510	1575	2090	2475	2850
200	3400	4350	4970	5490	2340	3050	3550	3825	1845	2500	2975	3350
225	3850	4750	5450	6020	2650	3375	4005	4450	1870	2550	3200	3700
250	4350	5450	6288	6920	3000	3825	4575	5100	2230	3010	3700	4350
280	4300	7000	8000	8830	2950	5400	6475	7270	1980	3550	4850	6550
315	5700	15750	17400	18500	3850	6210	7600	8350	2790	4100	4400	5300
355	6875	21500	24100	25500	4250	6975	8275	9350	2880	4230	4500	5400
355LX	5425	16700	20200	21000	3400	5885	6725	7600	-	-	-	-
400	5300	24700	27300	29050	3050	8010	8775	9800	-	-	-	-
450	-	29450	32000	34600	-	8100	8900	9750	-	-	-	-

(tab. 17)

◆ 3.19 Rulmenti

Lagarele de susținere a rotorului sunt introduse în scuturile motorului:

- **Rulment DE** (Capatul de Actionare): acesta este rulmentul frontal în corespondența cu arborele motorului.

- **Rulment NDE** (Capatul Negativ): acesta este rulmentul posterior, în corespondența cu ventilatorul de răcire. În versiunile standard, motoarele de la MEC56 la MEC132 au rulmenți de tip închis ZZ sau 2RS unși pe viața, de la MEC160 la MEC450, rulmenții sunt deschiși și echipați cu un niplu de ungere pentru lubrifiere periodică. Motoarele MEC400 și MEC450 au 2 rulmenți pe partea LA și 1 rulment pe partea NDE. Pentru a atenua dilatarea termică a rotorului în timpul funcționării motorului, există întotdeauna un inel de compensare care acționează în mod normal asupra rulmentului NDE preîncărcându-l spre interior; pentru motoarele cu frână sau pentru altele.

TIP DE RULMENT

Codurile de identificare pentru rulmenții cu rostogolire sunt standardizate la nivel internațional; ultimele trei cifre ale codului identifică dimensiunea rulmentului, prima parte a codului identifică tipul:

- **Rulmenți tip 6000:**

Rulmenții radiali cu bile suportă sarcini radiale și axiale medii; sunt potriviți pentru majoritatea instalațiilor și, prin urmare, sunt furnizați ca standard pentru motoare până la și inclusiv MEC250 sau în combinație cu rulmenți de tip NU... sau 7000.

- **Rulmenți de tip NU...:**

Rulmenții cilindrici suportă doar sarcini radiale mari; potriviți pentru aplicații cu sarcină radială pe partea DE (de exemplu, scripeti și angrenaje).

- **Rulmenți de tip 7000:** Aceștia sunt rulmenți axiali cu bile și suportă sarcini radiale mari și sarcini axiale mari într-o singură direcție. Sunt destinați numai instalării verticale.

AVERTISMENT: Pentru motoarele instalate vertical de la MEC280 la MEC450, este necesar să identificați poziția corectă de montare consultând tabelul „Forme de construcție și amplasare” (contactați aLLindustrial dacă este necesar); rulmenții axiali de tip 7000 trebuie orientați corespunzător pe partea DE, în sus sau în jos.

Bearings

The motor support bearings are inserted in the motor endshields:

- **Cuscinetto DE** (Drive End) bearing: this is the front bearing in correspondence with the motor shaft.

- **Cuscinetto NDE** (Non Drive End) bearing: this is the rear bearing, in correspondence with the cooling fan. In standard versions, motors from MEC56 to MEC132 have closed type bearings ZZ or 2RS greased for life, from MEC160 to MEC450, bearings are open and fitted with a greasing nipple for periodic lubrication. MEC400 and MEC450 motors have 2 bearings on the DE side and 1 bearing in the NDE side. To mitigate the thermal expansion of the rotor during motor operation, there is always a compensation ring that normally acts on the NDE bearing preloading it inwards; for brake motors or for other applications, the compensation ring acts on the DE bearing.

TYPE OF BEARING

The identification codes of roller support bearings are unified at an international level; the last 3 digits of the code identify the dimensions of the bearing, the first part of the code identifies the type:

- **Type 6000 bearings:**

radial ball bearings, support medium radial and axial loads; suitable for the majority of installations and therefore supplied standard for motors up to MEC250, including or combined with type NU... bearings or type 7000

- **Type NU... bearings:**

cylindrical roller, support only high radial loads; suitable for applications that weigh in a radial direction on the DE side (for example pulleys and spur gears)

- **Type 7000 bearings:** thrust ball bearings that support high radial and axial loads in one direction only; to be used only for vertical mounting arrangements.

ATTENTION: for motors from MEC280 to MEC450 installed in vertical arrangements, it is important to identify the correct mounting position using the “Configurations and mounting arrangements” table as a guide (contact aLLindustrial if necessary); type 7000 thrust ball bearings must be properly oriented for the DE side upwards or downwards.

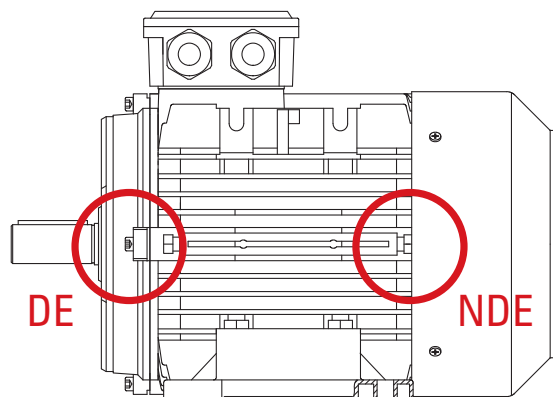

Date despre rulmenti / Bearing specifications

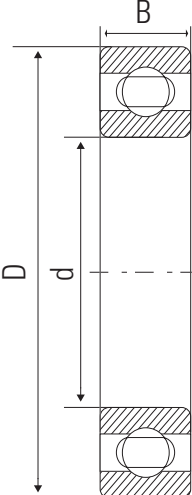

Dimensiunea motorului Motor size	Pozitia de montare a rotii sau a scripetelui Mounting position of wheel or pulley	DE DE	NDE NDE	DE Bearing / d	Rulmenti DE D	DE B
56	oriz./vert hor/ver	6201 C3	6201 C3	12	32	10
63	oriz./vert hor/ver	6201 C3	6201 C3	12	32	10
71	oriz./vert hor/ver	6202 C3	6202 C3	15	35	11
80	oriz./vert hor/ver	6204 C3	6204 C3	20	47	14
90	oriz./vert hor/ver	6205 C3	6205 C3	25	52	15
100	oriz./vert hor/ver	6206 C3	6206 C3	30	62	16
112	oriz./vert hor/ver	6306 C3	6206 C3	30	72	19
132	oriz./vert hor/ver	6308 C3	6208 C3	40	90	23
160	oriz./vert hor/ver	6309 C3	6309 C3	45	100	25
180	oriz./vert hor/ver	6311 C3	6311 C3	55	120	29
200	oriz./vert hor/ver	6312 C3	6312 C3	60	130	31
225	oriz./vert hor/ver	6313 C3	6313 C3	65	140	33
250	oriz./vert hor/ver(*)	6314 C3	6314 C3	70	150	35
280 2	orizontal / horizontal(*)	6314 C3	6314 C3	70	150	35
280 2	vertical / vertical(*)	6314 C3	7314	70	150	35
280 4-8	orizontal / horizontal(*)	6317 C3	6317 C3	85	180	41
280 4-8	vertical / vertical(*)	6317 C3	7317	85	180	41
315 2	orizontal / horizontal(*)	6316 C3	6316 C3	80	170	39
315 2	vertical / vertical(*)	6316 C3	7316	80	170	39
315 4-8	orizontal / horizontal(*)	NU319 C3	6319 C3	95	200	45
315 4-8	vertical / vertical(*)	NU319 C3	7319	95	200	45
355 2	orizontal / horizontal(*)	6319 C3	6319 C3	95	200	45
355 2	vertical / vertical(*)	6319 C3	7319	95	200	45
355 4-8	orizontal / horizontal(*)	NU322 C3	6322 C3	110	240	50
355 4-8	vertical / vertical(*)	NU322 C3	7322	110	240	50
355LX 2	orizontal / horizontal(*)	6319 C3	6319 C3	95	200	45
355LX 2	vertical / vertical(*)	6319 C3	7319	95	200	45
355LX 4-8	orizontal / horizontal(*)	NU324 C3	6324 C3	120	260	55
355LX 4-8	vertical / vertical(*)	NU324 C3	7324	120	260	55
400 2	orizontal / horizontal(*)	6319 C3	6319 C3	95	200	45
400 2	vertical / vertical(*)	6319 C3	7319	95	200	45
400 4-8	orizontal / horizontal(*)	NU224 C3+6224 C3	NU224 C3	120	215	40
400 4-8	vertical / vertical(*)	NU224 C3+7224	NU224 C3	120	215	40
450 2	orizontal / horizontal(*)	6319 C3	6319 C3	95	200	45
450 2	vertical / vertical(*)	6319 C3	7319	95	200	45
450 4	orizontal / horizontal(*)	NU226 C3+6226 C3	NU226 C3	130	230	40
450 4	vertical / vertical(*)	NU226 C3+7226	NU226 C3	130	230	40
450 6-8	orizontal / horizontal(*)	NU228 C3+6228 C3	NU228 C3	140	250	42
450 6-8	vertical / vertical(*)	NU228 C3	7228+7228	140	250	42

(*): Sunt disponibili si rulmenti cu role conice; contactati aLLindustrialL pentru a identifica combinatia corecta intre rulmentii DE si NDE.
Tapered roller bearings can also be supplied; contact aLLindustrialL for information regarding correct pairings between DE and NDE bearings

(tab. 18)

Dimensiunile rulmentilor motorului din fonta si intervalele de lubrifiere *Bearing dimensions for cast iron motors and lubricating intervals*

	d	D	B	interval de lubrifiere in ore (h) pentru functionare la 50Hz <i>lubrication interval in hours (h) for operation at 50Hz</i>				grame de grasime (g) pentru rulment <i>grams of grease (g) for bearing</i>
				2P	4P	6P	8P	g
6309 C3	45	100	25	3400	6300	8000	9200	13
6311 C3	55	120	29	2900	5900	7600	8800	17
6312 C3	60	130	31	2500	5500	7200	8500	20
6313 C3	65	140	33	2300	5300	7100	8400	23
6314 C3	70	150	35	2100	5200	7000	8200	26
6316 C3	80	170	39	1800	4900	6700	8000	33
6317 C3	85	180	41	1700	4800	6600	7900	37
6319 C3	95	200	45	1300	4600	6500	7800	51
6322 C3	110	240	50	1300	4600	6500	7800	60
6324 C3	120	260	55	1100	3700	5600	7000	72
6224 C3	120	215	40	1100	3700	5600	7000	93
6226 C3	130	230	40	1000	3600	5300	6800	95
6228 C3	140	250	42	1000	3600	5300	6800	95
NU309 C3	45	100	25	1500	2900	3900	4400	13
NU311 C3	55	120	29	1300	2800	3600	4300	17
NU312 C3	60	130	31	1200	2700	3500	4200	20
NU313 C3	65	140	33	1100	2600	3500	4100	23
NU314 C3	70	150	35	1000	2500	3400	4000	26
NU316 C3	80	170	39	800	2300	3200	3900	33
NU317 C3	85	180	41	700	2300	3200	3800	37
NU319 C3	95	200	45	500	2200	3100	3800	51
NU322 C3	110	240	50	300	2100	3000	3700	60
NU324 C3	120	260	55	300	2000	2900	3600	72
NU224 C3	120	215	40	300	1800	2800	3400	93
NU226 C3	130	230	40	300	1800	2800	3400	93
NU228 C3	140	250	42	300	1800	2800	3400	93
7317	85	180	41	1400	4700	6600	7900	37
7319	95	200	45	1200	3800	5700	7100	51
7322	110	240	50	1200	3800	5700	7100	60
7324	120	260	55	1200	3800	5700	7100	72
7224	120	215	40	1200	3800	5700	7100	51
7226	130	230	40	1200	3800	5700	7100	60
7228	140	250	42	1200	3800	5700	7100	72

Intervalele de lubrifiere enumerate pentru rulmentii din seria 6000 si seria NU... se refera la utilizarea cu o axa orizontala la 50 Hz; pentru functionarea cu o axa verticala, intervalele trebuie injumatatite; pentru functionarea la 60 Hz, intervalele trebuie reduce cu 20%.

Recomandam utilizarea unei unsori de inalta performanta special concepute pentru motoare electrice, sapun de litiu pe baza minerala, consistenta 3 (NLGI) si viscozitate cinematica 100 (IP71 40°C).

The lubrication intervals indicated for series 6000 and NU... bearings refer to use with a horizontal axis at 50Hz; for operation with a vertical axis, intervals must be halved; for operation at 60Hz, intervals must be reduced by 20%.

We recommend using a specific high-performance grease for electric motors, which is mineral lithium soap based, with consistency 3 (NLGI) and kinematic viscosity 100 (IP71 40 °C).

(tab. 19)

Instalarea rulmentilor pentru motoarele din fonta
Installation of bearings for cast iron motors

160-280 2-8P

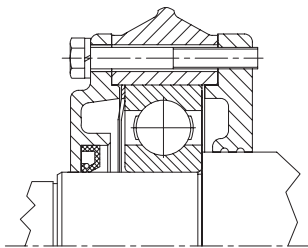

315-355 2P

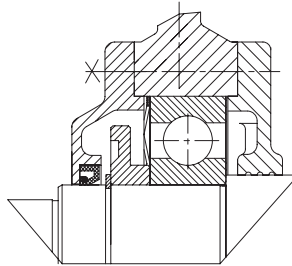

315-355 4-8P

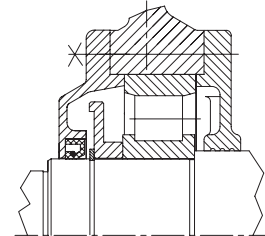

DE

NDE

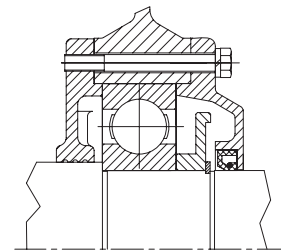
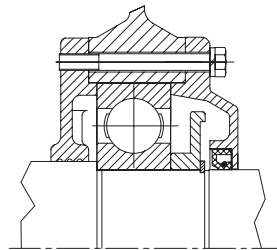
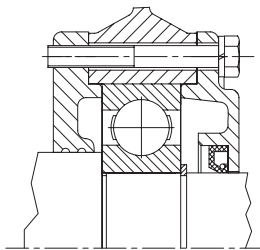

355LX-400 2P

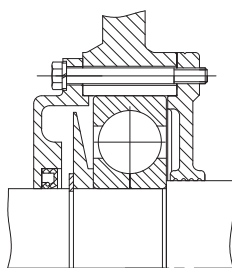

355LX 4-8P

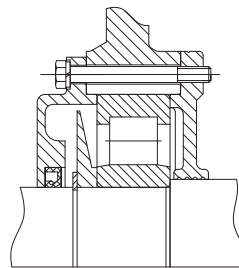

400 4-8P 450 2-8P

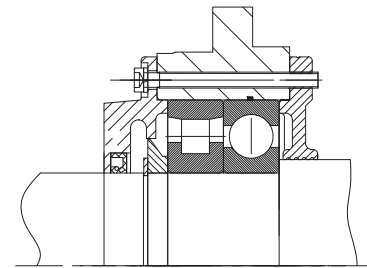

DE

NDE

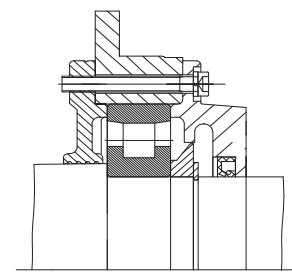
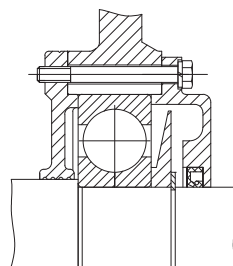
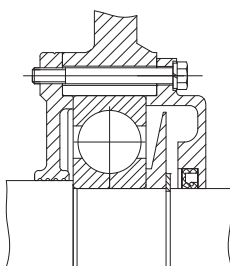

(tab. 20)



◆ 3.20 Dimensiunile garniturii de etansare a uleiului
Oil seal dimensions

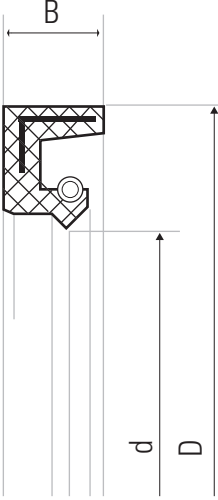

CADRU	DE			NDE		
	d	D	B	d	D	B
56	12	22	5	12	22	5
63	12	24	5	12	24	5
71	15	25	7	15	25	7
80	20	34	7	20	34	7
90	25	37	7	25	37	7
100	30	44	7	30	44	7
112	30	44	7	30	44	7
132	40	58	7	40	58	7
160	45	65	8	45	65	8
180	55	75	8	55	75	8
200	60	80	8	60	80	8
225	65	90	10	65	90	10
250	70	95	10	70	95	10
280 2	70	95	10	70	95	10
280 4-8	85	110	12	85	110	12
315 2	80	100	10	80	100	10
315 4-8	95	120	12	95	120	12
355 2	95	120	12	95	120	12
355 4-8	95	120	12	95	120	12
355LX 2	95	120	12	95	120	12
355LX 4-8	110	140	12	110	140	12
400 2	95	120	12	95	120	12
400 4-8	120	150	12	120	150	12
450 2	95	120	12	95	120	12
450 4	130	160	12	130	160	12
450 6-8	140	170	12	140	170	12

(tab. 21)

4.0 Performanta si date tehnice

Technical performance and specifications

◆ 4.1 Seria 6T3 / 7T3 - IE3 6T3 / 7T3 series - IE3

2 POLI / 2 POLES IE3 3000rpm													
Type	kW	hp	rpm	$\eta\%$ 100% load	$\eta\%$ 75% load	$\eta\%$ 50% load	cos ϕ	In (A) 400V 50Hz	Is In	Cn (Nm)	Cs Cn	Cmax Cn	kg
6T3 71C2	0,75	1	2830	81,6	81,7	79,1	0,81	1,63	7,10	2,48	3,0	3,2	7,9
6T3 80A2	0,75	1	2890	80,7	80,3	77,2	0,81	1,66	7,4	2,48	3,1	3,2	8,9
6T3 80B2	1,1	1,5	2890	82,7	82,5	79,9	0,83	2,31	8,7	3,63	3,4	3,4	10,6
6T3 80C2	1,5	2	2900	85,4	85,1	82,6	0,81	3,15	9,5	4,91	4,1	4,1	12
6T3 90S2	1,5	2	2900	84,2	83,8	81,4	0,82	3,14	8,3	4,94	3,5	3,7	14,0
6T3 90L2	2,2	3	2910	85,9	86,1	84,7	0,82	4,51	8,1	7,22	3,1	3,5	16,3
6T3 90LB2	3	4	2910	87,1	87,1	84,2	0,80	6,21	9,6	9,85	4	4,1	18,5
6T3 100L2	3	4	2910	87,1	87,5	86,3	0,89	5,59	9,4	9,85	3,2	3,6	23,7
6T3 100LB2	4	5,5	2910	88,1	88,7	88,1	0,90	7,28	10,1	13,13	3,3	3,6	27,6
6T3 112M2	4	5,5	2920	88,1	88,2	87,0	0,91	7,20	10,5	13,08	3,4	3,9	30,1
6T3 112MB2	5,5	7,5	2920	89,2	89,6	89,1	0,91	9,78	11,9	17,99	3,3	4,2	35,7
6T3 132SA2	5,5	7,5	2930	89,2	89,4	88,2	0,89	10,0	10	17,93	3,2	4	43,4
6T3 132SB2	7,5	10	2930	90,1	90,2	89,1	0,90	13,4	11,9	24,45	3,6	4,7	51,7
6T3 132MA2	9,2	12,5	2930	90,6	91,2	90,5	0,91	16,1	11,6	29,99	3,2	4,2	58,3
6T3 132MB2	11	15	2930	91,2	91,5	91,2	0,92	18,9	12,2	35,85	3,6	4,1	63,5
7T3 160MA2	11	15	2940	91,2	91,1	89,8	0,89	19,6	8,1	35,73	2	2,3	120
7T3 160MB2	15	18	2940	91,9	91,8	90,7	0,89	26,5	8,1	48,72	2	2,3	130
7T3 160L2	18,5	25	2940	92,4	92,3	90,4	0,89	32,5	8,2	60,09	2	2,3	148
7T3 180M2	22	30	2955	92,7	92,6	91,6	0,89	38,5	8,2	71,10	2	2,3	192
7T3 200LA2	30	40	2965	93,3	93,2	92,1	0,89	52,1	7,6	96,63	2	2,3	248
7T3 200LB2	37	50	2965	93,7	93,5	92,3	0,89	64,0	7,6	119,17	2	2,3	270
7T3 225M2	45	60	2970	94	93,6	92,4	0,90	76,8	7,7	144,70	2	2,3	324
7T3 225MB2	55	75	2975	94,2	94,2	93,6	0,91	92,9	8	176,60	2,3	3	346
7T3 250M2	55	75	2975	94,3	94,1	93,0	0,90	93,5	7,7	176,55	2	2,3	438
7T3 250MB2	75	100	2975	94,7	94,3	93,0	0,90	127,0	7,1	240,76	1,8	2,3	486
7T3 280S2	75	100	2975	94,7	94,3	93,0	0,90	127,0	7,1	240,76	1,8	2,3	518
7T3 280M2	90	125	2975	95	94,6	94,3	0,90	151,9	7,1	288,91	1,8	2,3	584
7T3 280MB2	110	150	2980	95,2	94,8	93,6	0,90	185,3	7,1	352,52	1,8	2,3	746
7T3 315S2	110	150	2980	95,2	94,8	93,6	0,90	185,3	7,1	352,52	1,8	2,3	956
7T3 315M2	132	180	2980	95,4	95,0	93,9	0,90	221,9	7,1	423,02	1,8	2,3	1127
7T3 315LA2	160	220	2980	95,6	95,0	94,2	0,91	265,5	7,2	512,75	1,8	2,3	1106
7T3 315LB2	200	270	2980	95,8	95,1	94,2	0,91	331,1	7,2	640,94	1,8	2,2	1170
7T3 355MB2	250	340	2980	95,8	95,2	94,5	0,90	413,9	7,2	801,20	1,6	2,2	1730
7T3 355LB2	315	430	2980	95,8	95,2	94,8	0,91	521,5	7,2	1009,50	1,6	2,2	1910
7T3 355LX2	355	480	2980	95,8	95,2	94,5	0,91	587,8	2,5	1282	1,3	6,50	2148

Datele tehnice si caracteristicile pot fi supuse modificarilor / Technical data and performances may change

4. Performanta si date tehnice

4 POLI / 4 POLES IE3 1500rpm													
Type	kW	hp	rpm	$\eta\%$ 100% load	$\eta\%$ 75% load	$\eta\%$ 50% load	$\cos\phi$	I_n (A) 400V 50Hz	I_s — I_n	C_n (Nm)	C_s — C_n	C_{max} — C_n	kg
6T3 80B4	0,75	1	1440	82,5	82,5	80,1	0,69	1,90	6,3	4,97	3,1	3,1	11,7
6T3 80C4	1,1	1,5	1430	84,3	85,1	83,9	0,74	2,55	6,6	7,32	3,1	3,1	12,5
6T3 90S4	1,1	1,5	1440	84,1	84,2	82,9	0,73	2,59	7,1	7,30	4	3,4	15,1
6T3 90L4	1,5	2	1430	85,3	85,5	84,1	0,74	3,43	7,1	10,02	3,4	3,3	18
6T3 90LB4	2,2	3	1440	86,7	85,8	83,9	0,72	5,14	7,5	14,61	3,9	3,3	20
6T3 100LA4	2,2	3	1450	86,7	87,1	86,2	0,80	4,58	7,9	14,49	2,8	3,3	23,9
6T3 100LB4	3	4	1450	87,7	88,0	86,9	0,78	6,33	8,1	19,76	3,3	3,4	28,3
6T3 100LC4	4	5,5	1450	88,6	88,1	86,7	0,77	8,55	8,9	26,18	3,9	3,5	30,5
6T3 112M4	4	5,5	1450	88,6	88,8	88,2	0,82	7,95	8,6	26,34	3,1	3,7	33,9
6T3 112MB4	5,5	7,5	1450	89,6	89,9	89,1	0,80	11,2	9,1	36,12	3,8	3,6	36,1
6T3 132S4	5,5	7,5	1460	89,6	89,8	89,4	0,84	10,5	9	35,98	2,3	3,5	47,4
6T3 132M4	7,5	10	1460	90,4	90,9	90,3	0,84	14,3	8,9	49,06	2,6	3,4	57,4
6T3 132MA4	9,2	12,5	1460	90,8	91,3	90,7	0,82	17,8	10	60,18	3,2	3,6	60
6T3 132MB4	11	15	1460	91,4	92,0	91,6	0,84	20,7	10,5	71,95	3,5	3,7	67
7T3 160M4	11	15	1465	91,4	91,2	91,0	0,85	20,4	7,7	71,71	2,2	2,3	128
7T3 160L4	15	20	1465	92,1	91,9	91,7	0,86	27,3	7,8	97,78	2,2	2,3	150
7T3 180M4	18,5	25	1470	92,6	92,7	91,8	0,86	33,5	7,8	120,19	2	2,3	182
7T3 180L4	22	30	1475	93	93,3	92,9	0,86	39,7	7,8	142,44	2	2,3	208
7T3 200L4	30	40	1475	93,6	93,3	92,1	0,86	53,8	7,3	194,24	2	2,3	268
7T3 225S4	37	50	1480	93,9	94,0	93,5	0,86	66,1	7,4	238,75	2	2,3	332
7T3 225M4	45	60	1480	94,2	94,3	93,8	0,86	80,2	7,4	290,37	2	2,3	342
7T3 250M4	55	75	1480	94,6	94,3	93,5	0,86	97,6	7,4	354,90	2,2	2,3	460
7T3 250MB4	75	100	1480	94,6	94,7	94,1	0,90	127,0	6,9	482,80	2,2	2,9	480
7T3 280S4	75	100	1485	95	94,7	93,5	0,88	129,5	6,9	482,32	2	2,3	556
7T3 280M4	90	125	1485	95,2	94,9	93,7	0,88	155,1	6,9	578,79	2	2,3	658
7T3 280MB4	110	150	1485	94,9	94,8	93,9	0,90	186,0	6,8	706,60	2	2,3	678
7T3 315S4	110	150	1485	95,4	95,5	94,6	0,89	187,0	7	707,41	2	2,2	914
7T3 315M4	132	180	1485	95,6	95,4	95,1	0,89	223,9	7	848,89	2	2,2	1034
7T3 315LA4	160	220	1485	95,8	95,5	95,3	0,89	270,9	7,1	1028,96	2	2,2	1078
7T3 315LB4	200	270	1485	96	95,6	95,2	0,90	334,1	7,1	1286,20	2	2,2	1160
7T3 315LC4	250	340	1490	96	96,2	95,7	0,88	427,2	6,2	1602,00	1,5	2,5	1643
7T3 355M4	250	340	1490	96	95,7	95,1	0,90	417,7	7,1	1602,30	2	2,2	1706
7T3 355L4	315	430	1490	96	95,7	95,1	0,90	526,2	7,1	2018,90	2	2,2	1820
7T3 355LB4	355	480	1490	96	95,7	95,1	0,88	606,5	7	2275,30	1,7	2,2	1922

Datele tehnice si caracteristicile pot fi supuse modificarilor / Technical data and performances may change

6 POLI / 6 POLES IE3 1000rpm													
Type	kW	hp	rpm	$\eta\%$ 100% load	$\eta\%$ 75% load	$\eta\%$ 50% load	cos ϕ	In (A) 400V 50Hz	$\frac{I_s}{I_n}$	Cn (Nm)	$\frac{C_s}{C_n}$	$\frac{C_{max}}{C_n}$	kg
6T3 80C6	0,75	1	950	78,70	78,30	74,70	0,63	2,19	4,80	7,61	2,8	2,8	12,2
6T3 90S6	0,75	1	950	78,9	80,1	78,1	0,67	2,05	4,7	7,54	2,3	2,6	13,8
6T3 90L6	1,1	1,5	950	81	81,1	78,4	0,67	2,93	5,2	11,06	2,7	2,9	16,2
6T3 90LB	1,5	2	950	82,5	82,7	80,5	0,67	3,93	5,6	15,10	2,9	3,1	18,7
6T3 100L6	1,5	2	955	82,5	83,0	81,8	0,70	3,75	5,5	15,00	2,4	2,9	22,1
6T3 112M6	2,2	3	965	84,3	84,5	83,2	0,68	5,54	5,5	21,77	2	2,5	27,1
6T3 132S6	3	4	965	85,6	86,0	85,1	0,74	6,84	6	29,69	2	2,7	38,6
6T3 132MA6	4	5,5	970	86,8	87,1	86,2	0,74	8,99	6,8	39,38	2,3	3	47,6
6T3 132MB6	5,5	7,5	975	88	88,3	87,1	0,71	12,7	7,4	53,9	2,9	3,5	55,7
6T3 132MC6	7,5	10	970	89,1	89,6	88,6	0,72	16,9	8,2	73,7	3,3	3,3	67,6
7T3 160M6	7,5	10	970	89,1	89,2	87,8	0,79	15,4	7	73,8	2	2,1	116
7T3 160L6	11	15	970	90,3	90,5	89,4	0,8	22,0	7,2	108,3	2	2,1	140
7T3 180L6	15	20	975	91,2	91,4	90,8	0,81	29,3	7,3	146,9	2	2,1	188
7T3 200LA6	18,5	25	975	91,7	92	91,4	0,81	36,0	7,3	181,2	2	2,1	234
7T3 200LB6	22	30	975	92,2	92,4	91,9	0,81	42,5	7,4	215,5	2	2,1	256
7T3 225M6	30	40	985	92,9	93,1	92	0,83	56,2	6,9	290,9	2	2,1	308
7T3 250M6	37	50	985	93,3	93,3	92,5	0,84	68,1	7,1	358,7	2	2,1	408
7T3 280S6	45	60	985	93,7	92,6	91,4	0,85	81,6	7,3	436,3	2	2	502
7T3 280M6	55	75	985	94,1	93,9	93	0,86	98,1	7,3	533,2	2	2	590
7T3 315S6	75	100	990	94,6	94,45	93,8	0,84	136,2	6,6	723,5	2	2	848
7T3 315M6	90	125	990	94,9	94,68	94,1	0,85	161,0	6,7	868,2	2	2	942
7T3 315LA6	110	150	990	95,1	94,9	94,6	0,85	196,4	6,7	1061,1	2	2	1004
7T3 315LB6	132	180	990	95,4	95,1	94,7	0,86	232,2	6,8	1273,3	2	2	1140
7T3 355MA6	160	220	990	95,6	95,3	94,5	0,86	280,9	6,8	1543,4	1,8	2	1606
7T3 355MB6	200	270	990	95,8	95,4	94,6	0,87	346,4	6,8	1929,3	1,8	2	1768
7T3 355LB6	250	340	990	95,8	95,4	94,6	0,87	433,0	6,8	2411,6	1,8	2	1902
7T3 355LX6	315	430	990	95,8	95,4	94,6	0,86	551,9	5,8	3039,0	1,6	2,6	2231
7T3 355LX6	355	480	990	95,8	96	95,5	0,86	622,0	5,8	3425,0	1,6	2,6	2214
7T3 400M6	355	480	990	95,8	96	95,5	0,86	622,0	5,8	3425,0	1,6	2,6	2900

Datele tehnice si caracteristicile pot fi supuse modificarilor / Technical data and performances may change

◆ 4.2 Seria 6T2/7T2 - IE2 6T2 / 7T2 series - IE2

2 POLI / 2 POLES IE2 3000rpm													
Type	kW	hp	rpm	$\eta\%$ 100% load	$\eta\%$ 75% load	$\eta\%$ 50% load	cos ϕ	In (A) 400V 50Hz	Is In	Cn (Nm)	Cs Cn	Cmax Cn	kg
6T2 71C2	0,75	1	2810	77,4	77,9	76,0	0,80	1,69	5,7	2,5	3,4	3,5	7,5
6T2 80A2	0,75	1	2840	77,4	78,0	75,2	0,81	1,73	6,1	2,52	2,6	2,8	8,4
6T2 80B2	1,1	1,5	2860	79,6	79,9	77,5	0,82	2,43	7	3,67	2,6	2,6	9,8
6T2 80C2	1,5	2	2880	81,3	82,0	80,4	0,84	3,17	7,4	4,97	2,9	3,1	11,3
6T2 90S2	1,5	2	2880	81,3	81,6	79,5	0,82	3,25	7,2	4,97	2,8	3	12,4
6T2 90L2	2,2	3	2890	83,2	83,8	82,1	0,83	4,60	7,6	7,27	2,8	3,1	15,0
6T2 90LB2	3	4	2880	84,6	85,8	85,2	0,85	6,02	7,9	9,95	3,4	3,3	17,2
6T2 100L2	3	4	2910	84,6	84,9	83,5	0,84	6,09	8,8	9,85	3,1	3,5	21,7
6T2 100LB2	4	5,5	2910	85,8	86,0	84,7	0,87	7,73	9,9	13,13	3,7	4,2	25,8
6T2 112M2	4	5,5	2920	85,8	86,2	85,0	0,89	7,56	9,6	13,08	3,3	3,6	26,7
6T2 112MB2	5,5	7,5	2920	87	87,3	86,1	0,87	10,5	10,2	17,99	3,4	4,1	32,5
6T2 132SA2	5,5	7,5	2920	87	87,6	86,6	0,89	10,3	8,3	17,99	2,4	3,4	39,7
6T2 132SB2	7,5	10	2920	88,1	88,5	87,5	0,89	13,8	10,3	24,53	3,1	3,7	47,3
6T2 132MA2	9,2	12,5	2920	88,7	89,0	88,1	0,89	16,8	10,8	30,09	3,4	4,1	52
6T2 132MB2	11	15	2930	89,4	89,6	88,7	0,9	19,7	12,7	35,85	4	3,9	58,5
7T2 160MA2	11	15	2930	89,4	89,7	87,9	0,89	20,0	6	35,90	2,1	2,8	108
7T2 160MB2	15	20	2935	90,3	90,6	90,1	0,89	26,9	6,9	48,80	2,5	3,1	122
7T2 160L2	18,5	25	2930	90,9	91,2	91,0	0,89	33,0	6,2	60,20	2,2	2,8	136
7T2 160LB2	22	30	2950	91,3	91,7	91,4	0,89	39,1	7,1	71,20	2,3	3,3	154
7T2 180M2	22	30	2950	91,3	91,7	91,4	0,89	39,1	7,1	71,20	2,3	3,3	172
7T2 180MB2	30	40	2930	92	91,8	91,0	0,89	52,9	6,7	96,80	1,8	3,2	215
7T2 200LA2	30	40	2960	92	92,1	91,7	0,89	52,9	6,7	96,80	1,8	3,2	234
7T2 200LB2	37	50	2960	92,5	92,6	91,9	0,89	64,9	6,9	119,40	1,9	3,3	242
7T2 200LC2	45	60	2965	92,9	92,8	91,6	0,89	78,6	6,3	144,80	1,8	3,1	275
7T2 225M2	45	60	2965	92,9	92,8	91,6	0,89	78,6	6,3	144,80	1,8	3,1	308
7T2 225MB2	55	75	2965	93,2	93,8	93,3	0,89	95,7	6,1	177,00	1,8	2,9	330
7T2 250M2	55	75	2965	93,2	93,8	93,3	0,89	95,7	6,1	177,00	1,8	2,9	402
7T2 250MB2	75	100	2975	93,4	94,2	93,8	0,89	130,2	6,9	240,80	1,8	2,3	545
7T2 280S2	75	100	2970	93,8	93,9	93,5	0,89	129,7	6	240,90	1,7	2,9	524
7T2 280M2	90	125	2970	94,1	94,2	93,6	0,89	155,1	5,9	289,20	1,8	2,8	616
7T2 315S2	110	150	2980	94,3	94,5	93,9	0,9	187,1	6,7	352,70	2	3,2	890
7T2 315M2	132	180	2980	94,6	95,0	94,1	0,9	223,8	7,5	423,30	2,4	3,6	970
7T2 315LA2	160	220	2975	94,8	94,9	94,2	0,91	267,7	6,3	513,80	2	3	1070
7T2 315LB2	200	270	2980	95	95,2	94,6	0,91	333,9	7,6	641,20	2,6	3,7	1136
7T2 355M2	250	340	2980	95	95,1	94,3	0,92	412,9	6,1	801,10	1,5	2,4	1420
7T2 355L2	315	430	2980	95	95,1	94,4	0,92	520,2	6	1009,50	1,5	2,3	1834
7T2 355LX2	355	480	2980	95	95,2	94,5	0,92	586,3	6,5	1139,10	1,3	2,5	2148

Datele tehnice s caracteristicile pot avea variatii / Technical data and performances may change

4. Prestatii si date tehnice

4 POLI / 4 POLES IE2 1500rpm													
Type	kW	hp	rpm	$\eta\%$ 100% load	$\eta\%$ 75% load	$\eta\%$ 50% load	$\cos\phi$	I_n (A) 400V 50Hz	I_s — I_n	C_n (Nm)	C_s — C_n	C_{max} — C_n	kg
6T2 80B4	0,75	1	1420	79,6	79,8	77,1	0,71	1,92	5,7	5,04	2,7	2,9	10,4
6T2 80C4	1,1	1,5	1420	81,4	81,9	79,7	0,72	2,71	5,9	7,40	3,1	3,1	12,3
6T2 90S4	1,1	1,5	1440	81,4	81,8	79,8	0,74	2,64	6,8	7,30	2,9	3,1	13,9
6T2 90L4	1,5	2	1440	82,8	83,2	81,6	0,74	3,53	6,5	9,95	3,1	3,2	16,5
6T2 90LB4	2,2	3	1430	84,3	85,3	84,3	0,75	5,02	7,1	14,69	3,4	2,4	18,8
6T2 100LA4	2,2	3	1440	84,3	85,2	84,3	0,82	4,59	6,6	14,59	2,4	2,9	22,2
6T2 100LB4	3	4	1450	85,5	86,1	84,9	0,8	6,33	7,6	19,76	2,3	3,2	25,9
6T2 100LC4	4	5,5	1440	86,6	87,4	86,5	0,8	8,33	7,2	26,53	2,8	3,2	28,6
6T2 112M4	4	5,5	1440	86,6	87,7	87,2	0,82	8,13	7,9	26,53	2,5	3,3	31,4
6T2 112MB4	5,5	7,5	1440	87,7	88,6	88,1	0,8	11,3	8,3	36,48	3,7	3,6	36,7
6T2 132S4	5,5	7,5	1460	87,7	88,1	87,0	0,83	10,9	8,6	35,98	2,1	3,5	44,3
6T2 132M4	7,5	10	1460	88,7	89,4	88,6	0,83	14,7	8,9	49,06	2,7	3,2	54,5
6T2 132MA4	9,2	12,5	1460	89,2	90,1	89,9	0,85	17,5	8,7	60,18	2,9	3,2	56,6
6T2 132MB4	11	15	1460	89,8	90,5	90,1	0,85	20,8	9,3	71,95	3,3	3,6	66,2
7T2 160M4	11	15	1465	89,8	90,0	89,4	0,85	20,8	6,3	71,60	1,8	3	118
7T2 160L4	15	20	1470	90,6	90,8	90,1	0,86	27,8	7,3	97,40	2,3	3,4	134
7T2 160LB4	18,5	25	1470	91,2	91,8	89,0	0,86	34,0	7,7	120,25	2,4	2,9	155
7T2 180M4	18,5	25	1470	91,2	91,8	91,0	0,86	34,0	6,8	120,00	1,9	3	176
7T2 180L4	22	30	1470	91,6	92,0	91,6	0,86	40,3	6,9	142,70	2	3	196
7T2 180LB4	30	40	1470	92,3	92,4	91,8	0,86	54,6	7,1	194,00	2,1	2,3	202
7T2 200L4	30	40	1470	92,3	92,4	91,8	0,86	54,6	6,1	194,50	2,2	2,7	242
7T2 200LB4	37	50	1475	92,4	92,8	92,4	0,86	66,9	6,2	239,50	2,4	2,6	269
7T2 225S4	37	50	1480	92,7	92,9	92,5	0,86	67,0	6,4	238,60	2,1	2,6	296
7T2 225M4	45	60	1480	93,1	93,4	93,0	0,86	81,1	6,7	290,10	2,4	2,7	328
7T2 225MB4	55	75	1480	93,8	94,0	93,6	0,88	96,2	6,1	354,50	2	2,6	374
7T2 250M4	55	75	1480	93,5	93,7	93,6	0,86	98,7	6,1	354,50	2	2,6	420
7T2 250MB4	75	100	1480	93,7	93,8	93,7	0,86	134,3	6,8	482,30	2,2	2,3	471
7T2 280S4	75	100	1485	94	94,1	93,7	0,88	130,9	6,5	481,80	2,1	2,8	540
7T2 280M4	90	125	1485	94,2	94,3	93,7	0,88	156,7	6,4	578,30	2,1	2,7	622
7T2 315S4	110	150	1485	94,5	94,7	94,2	0,88	190,9	6,7	706,30	2,2	2,9	848
7T2 315M4	132	180	1485	94,7	94,6	94,3	0,88	228,6	7,4	848,00	2,4	2,9	942
7T2 315LA4	160	220	1485	94,9	95,0	94,6	0,89	273,4	6,7	1027,50	2,3	2,8	1018
7T2 315LB4	200	270	1485	95,1	94,9	94,6	0,89	341,1	6,2	1285,10	2,2	2,6	1158
7T2 315LC4	250	340	1490	95	95,4	94,5	0,88	431,6	6,2	1602,00	1,5	2,5	1503
7T2 355M4	250	340	1490	95,1	95,1	94,6	0,9	421,6	6,7	1603,90	2,1	2,5	1660
7T2 355L4	315	430	1490	95,1	95,0	94,8	0,9	531,2	7,1	2020,30	2,1	2,2	1690
7T2 355LB4	355	480	1490	95,1	95,2	94,7	0,9	598,7	7	2277,72	2,1	2,2	1757

Datele tehnice si caracteristicile pot avea variatii / Technical data and performances may change

6 POLI / 6 POLES IE2 1000rpm													
Type	kW	hp	rpm	$\eta\%$ 100% load	$\eta\%$ 75% load	$\eta\%$ 50% load	cos ϕ	In (A) 400V 50Hz	Is In	Cn (Nm)	Cs Cn	Cmax Cn	kg
6T2 80C6	0,75	1	920	75,9	75,4	71,3	0,67	2,13	4,2	7,79	2,7	2,6	11,7
6T2 90S6	0,75	1	940	75,9	75,3	71,1	0,65	2,19	4,5	7,62	2,2	2,5	12,6
6T2 90L6	1,1	1,5	950	78,1	78,4	75,6	0,69	2,95	4,9	11,06	2	2,4	15,2
6T2 90LB6	1,5	2	945	79,8	80,1	77,5	0,68	3,99	5,1	15,16	2,7	3	18,2
6T2 100L6	1,5	2	950	79,8	81,7	81,2	0,74	3,67	4,8	15,08	1,7	2,2	20,7
6T2 100LB6	2,2	3	950	81,8	82,6	81,1	0,72	5,39	5,5	22,12	2,5	2,7	25
6T2 112M6	2,2	3	955	81,8	82,9	81,8	0,73	5,32	5,5	22,00	2,1	2,7	26
6T2 112MB6	3	4	955	83,3	84,4	83,3	0,72	7,22	5,7	30,00	2,3	2,8	31
6T2 132S6	3	4	960	83,3	84,8	84,4	0,76	6,84	5,6	29,84	1,6	2,4	37,8
6T2 132MA6	4	5,5	965	84,6	85,6	84,8	0,74	9,22	5,9	39,59	2	2,6	43,8
6T2 132MB6	5,5	7,5	965	86	87,2	86,8	0,75	12,3	6,6	54,43	2,4	2,6	51,8
6T2 132MC6	7,5	10	970	87,2	87,8	87,0	0,76	16,3	7,9	73,84	3,1	3,2	66
7T2 160M6	7,5	10	970	87,2	87,8	87,1	0,78	15,9	5,7	73,90	2,2	2,8	112
7T2 160L6	11	15	970	88,7	89,2	88,5	0,79	22,7	5,8	108,10	2,2	2,8	134
7T2 180L6	15	20	980	89,7	90,2	90,1	0,81	29,8	6,9	146,30	2,1	2,7	176
7T2 200LA6	18,5	25	980	90,4	90,6	90,0	0,81	36,5	5,9	180,10	2	2,6	223
7T2 200LB6	22	30	980	90,9	91,2	90,7	0,82	42,60	5,9	214,10	2	2,6	234
7T2 200LC6	30	40	985	91,8	92,4	92,3	0,81	54,80	5,7	291,40	1,9	2,2	263
7T2 225M6	30	40	985	91,7	92,2	91,9	0,81	58,30	5,7	291,40	1,9	2,2	292
7T2 250M6	37	50	985	92,2	92,6	92,4	0,84	69,00	6,4	358,60	2,2	2,7	388
7T2 280S6	45	60	990	92,7	92,9	92,5	0,86	81,50	6,4	434,60	2,2	2,7	494
7T2 280M6	55	75	990	93,1	93,3	92,9	0,86	99,20	6,4	531,20	2,1	2,6	516
7T2 280MB6	75	100	990	93,4	93,7	93,0	0,86	134,80	6,7	722,80	2,3	2,9	723
7T2 315S6	75	100	990	93,7	93,6	92,8	0,85	135,90	6,7	722,80	2,3	2,9	765
7T2 315M6	90	125	990	94	93,9	93,3	0,84	164,50	6,8	867,30	2,4	2,9	938
7T2 315LA6	110	150	990	94,3	94,4	93,7	0,85	198,1	6,2	1061,20	2,2	2,6	1024
7T2 315LB6	132	180	990	94,6	94,6	94,1	0,86	234,2	7,1	1271,60	2,6	2,9	1110
7T2 315LC6	160	220	990	94,8	94,7	94,3	0,89	283,3	6,7	1543,40	2	2	1400
7T2 355MA6	160	220	990	95	94,9	94,4	0,87	279,4	6,5	1543,50	2	2,6	1560
7T2 355MB6	200	270	990	95	95,1	94,7	0,87	349,3	6,3	1929,30	1,9	2,5	1600
7T2 355L6	250	340	990	95	95,2	95,0	0,87	436,6	6,3	2415,30	1,7	2,2	1840
7T2 355LX6	315	430	990	95	95,2	94,5	0,86	556,5	5,8	3039,00	1,6	2,6	2150
7T2 355LXB6	355	480	990	95	95,2	94,8	0,87	620,0	5,8	3425,00	1,6	2,6	2454
7T2 400M6	355	480	990	95	95,2	94,5	0,86	627,2	5,8	3425,00	1,6	2,6	2820

Datele tehnice si caracteristicile pot avea variatii / Technical data and performances may change

◆ 4.3 Seria 6T1 / 7T1 - IE1 6T1 / 7T1 series - IE1

2 POLI / 2 POLES IE1 3000rpm												
Type	kW	hp	rpm	$\eta\%$ 100% load	cos ϕ	In (A) 400V 50Hz	$\frac{I_s}{I_n}$	Cn (Nm)	$\frac{C_s}{C_n}$	$\frac{C_{max}}{C_n}$	kg	
6T1 56A2	0,09	0,12	2670	57	0,72	0,35	6	0,32	2,2	2,4	2,8	
6T1 56B2	0,12	0,16	2730	62	0,72	0,42	6	0,42	2,2	2,4	3,2	
6T1 56C2	0,18	0,25	2750	65	0,72	0,56	6	0,63	2,2	2,4	3,5	
6T1 63A2	0,18	0,25	2710	63	0,75	0,55	6	0,63	2,2	2,4	3,7	
6T1 63B2	0,25	0,34	2710	65	0,78	0,71	6	0,88	2,2	2,4	4,1	
6T1 63C2	0,37	0,5	2710	65	0,78	1,05	6	1,30	2,2	2,4	4,6	
6T1 71A2	0,37	0,5	2730	70	0,79	0,97	6	1,29	2,2	2,4	5,34	
6T1 71B2	0,55	0,75	2760	71	0,79	1,42	6	1,90	2,2	2,4	6,14	
6T1 71C2	0,75	1	2730	72	0,82	1,83	6	2,62	2,2	2,4	7,1	
6T1 80A2	0,75	1	2860	69,2	0,83	1,88	5,7	2,50	2,1	2,5	8,15	
6T1 80B2	1,1	1,5	2870	79	0,83	2,42	6,5	3,66	2,6	2,8	9,7	
6T1 80C2	1,5	2	2870	81	0,83	3,22	6,8	4,99	2,7	2,8	11	
6T1 90S2	1,5	2	2880	80	0,83	3,3	6,6	4,97	2,3	2,8	12,3	
6T1 90L2	2,2	3	2880	83,5	0,84	4,5	7,1	7,30	2,6	2,7	14,9	
6T1 90LB2	3	4	2900	86	0,85	5,9	8,1	9,88	2,9	3	17,1	
6T1 100L2	3	4	2900	83	0,84	6,2	7,7	9,88	2,7	3,2	20,1	
6T1 100LB2	4	5,5	2890	84,5	0,83	8,2	8,1	13,22	3,1	3,6	23	
6T1 112M2	4	5,5	2910	85	0,87	7,8	9,2	13,13	2,8	3,6	26,15	
6T1 112MB2	5,5	7,5	2900	86,5	0,88	10,4	9,8	18,11	3	3,8	31,2	
6T1 132SA2	5,5	7,5	2890	84,4	0,87	10,8	6,8	18,17	2,2	2,8	37,6	
6T1 132SB2	7,5	10	2890	88	0,87	14,1	8,2	24,78	2,7	3,2	45	
6T1 132MA2	9,2	12,5	2910	88	0,9	16,8	9,7	30,19	3,1	3,8	51	
6T1 132MB2	11	15	2920	89	0,89	20,0	10,7	35,98	3,3	4	56,5	
7T1 160MA2	11	15	2930	87,6	0,89	20,4	6,7	35,8	2,6	2,9	101	
7T1 160MB2	15	20	2930	88,7	0,9	27,4	6,7	48,8	2,6	2,9	111	
7T1 160L2	18,5	25	2930	89,3	0,9	33,2	6,8	60,4	2,5	2,8	126	
7T1 160LB2	22	30	2930	89,9	0,9	37,6	6,8	71,4	2,5	2,8	158	
7T1 180M2	22	30	2940	89,9	0,9	39,2	6,6	71,4	2,6	2,8	176	
7T1 180MB2	30	40	2950	90,7	0,9	52,5	6,6	96,9	2,6	2,8	190	
7T1 200LA2	30	40	2950	90,7	0,9	53,0	6,5	97,2	2,5	2,7	226	
7T1 200LB2	37	50	2950	91,2	0,9	65,1	6,5	119,8	2,4	2,6	245	
7T1 225M2	45	60	2970	91,7	0,9	78,7	6,8	144,8	2,4	2,6	280	
7T1 250M2	55	75	2970	92,1	0,9	95,8	6,8	177	2,5	2,8	379	
7T1 280S2	75	100	2970	92,7	0,9	129,8	6,7	241,3	2,4	2,7	512	
7T1 280M2	90	125	2970	93,0	0,91	153,5	6,7	289,5	2,4	2,7	578	
7T1 315S2	110	150	2980	93,3	0,91	187,0	6,6	352,7	2	2,5	845	
7T1 315M2	132	180	2980	93,5	0,91	223,9	6,6	423,2	2,1	2,5	942	
7T1 315LA2	160	220	2980	93,8	0,91	270,6	6,7	513	1,9	2,4	1019	
7T1 315LB2	200	270	2980	94,0	0,92	333,8	6,7	641,2	1,9	2,4	1177	
7T1 355M2	250	340	2980	94,0	0,92	417,3	6,5	801,5	1,6	2,3	1638	
7T1 355L2	315	430	2980	94,0	0,92	520,1	6,5	1010	1,6	2,3	1834	
7T1 355LB2	355	483	2980	94,0	0,91	584,7	6,5	1137,7	1,3	2,5	2300	
7T1 355LX2	400	540	2980	94,0	0,9	682,5	6,5	1282,0	1,3	2,5	2150	
7T1 400M2	450	600	2980	94,0	0,9	767,8	6,5	1442,0	1,3	2,5	2620	
7T1 400L2	500	680	2980	94,0	0,9	853,1	6,5	1602,0	1,3	2,5	2720	
7T1 400LB2	560	760	2980	95,5	0,9	940,0	7,5	1975,0	1,2	2,6	3200	
7T1 400LC2	630	840	2980	95,6	0,9	1057,0	7,5	2019,0	1,2	2,6	3490	
7T1 400LD2	710	965	2980	95,6	0,9	1191,0	7,5	2275,0	1,2	2,6	3660	
7T1 450L2	560	760	2980	94,0	0,9	955,5	6,5	1795,0	1,3	2,5	3340	
7T1 450LB2	800	1075	2985	95,6	0,88	1373,0	7,2	2559,0	0,8	2	5000	
7T1 450LC2	900	1200	2985	95,7	0,88	1543,0	7,2	2879,0	0,8	2	5200	
7T1 450LD2	1000	1340	2985	95,8	0,88	1712,0	7,2	3199,0	0,8	2	5500	

Datele tehnice si caracteristicile pot fi supuse modificarilor / Technical data and performances may change

6 POLI / 6 POLES IE1 1000rpm											
Type	kW	hp	rpm	η % 100% load	cos ϕ	In (A) 400V 50Hz	$\frac{I_s}{I_n}$	Cn (Nm)	$\frac{C_s}{C_n}$	$\frac{C_{max}}{C_n}$	kg
6T1 63A6	0,09	0,12	840	42,0	0,61	0,51	3,5	1,02	2	2	4,2
6T1 63B6	0,12	0,16	850	45,0	0,62	0,62	3,5	1,35	2	2	4,5
6T1 71A6	0,18	0,25	880	56,0	0,66	0,70	4	1,95	1,6	1,7	5,6
6T1 71B6	0,25	0,34	900	59,0	0,7	0,87	4	2,65	2,1	2,2	6
6T1 71C6	0,37	0,5	890	61,0	0,69	1,27	4	3,97	2	2,1	6,8
6T1 80A6	0,37	0,5	910	61,0	0,66	1,33	3,2	3,88	1,9	2,2	8
6T1 80B6	0,55	0,75	910	65,5	0,65	1,86	3,5	5,77	2,1	2,3	9,25
6T1 80C6	0,75	1	910	70,5	0,69	2,2	3,8	7,87	2,1	2,2	10,6
6T1 90S6	0,75	1	940	71,5	0,68	2,2	4,1	7,62	1,8	2,2	11,8
6T1 90L6	1,1	1,5	930	73,5	0,66	3,3	4,1	11,30	1,9	2,3	14,2
6T1 90LB6	1,5	2	930	75,0	0,69	4,2	4,3	15,40	2	2,2	15,5
6T1 100L6	1,5	2	940	77,0	0,69	4,1	4,6	15,24	1,9	2,6	18,7
6T1 100LB6	2,2	3	940	79,5	0,75	5,3	5,1	22,35	2	2,3	22,8
6T1 112M6	2,2	3	945	79,3	0,69	5,8	4,8	22,23	1,9	2,3	24,5
6T1 112MB6	3	4	950	81,0	0,69	7,7	5	30,16	1,9	2,8	28,5
6T1 132S6	3	4	960	82,5	0,72	7,3	5,7	29,84	1,9	2,5	36,4
6T1 132MA6	4	5,5	965	84,5	0,73	9,4	5,9	39,59	2	2,6	42,2
6T1 132MB6	5,5	7,5	950	85,5	0,72	12,9	6,2	55,29	2,1	2,7	51,4
6T1 132MC6	7,5	10	965	87,0	0,75	16,6	7,3	74,22	2,7	2,9	62,6
7T1 160M6	7,5	10	970	84,7	0,77	16,6	5,6	73,90	2	2,6	103
7T1 160L6	11	15	970	86,4	0,78	23,6	5,8	108,3	2,1	2,4	121
7T1 180L6	15	20	970	87,7	0,81	30,5	5,7	147,7	2	2,4	173
7T1 200LA6	18,5	25	970	88,6	0,81	37,2	6,7	182,2	2,2	2,8	221
7T1 200LB6	22	30	970	89,2	0,83	42,9	6,6	216,7	2,3	2,9	236
7T1 225M6	30	40	980	90,2	0,84	57,2	6,8	292,5	2,2	2,7	301
7T1 250M6	37	50	980	90,8	0,86	68,4	6,2	360,7	2	2,5	370
7T1 280S6	45	60	980	91,4	0,86	82,6	6,1	438,7	1,9	2,5	478
7T1 280M6	55	75	980	91,9	0,86	100,4	6,7	536,2	2,1	2,7	535
7T1 280MB6	75	100	985	92,6	0,87	133	5,8	727,2	2,1	2,3	682
7T1 315S6	75	100	990	92,6	0,86	135,9	6,5	723,8	2	2,7	790
7T1 315M6	90	125	990	92,9	0,86	162,6	6,2	868,6	2	2,6	880
7T1 315LA6	110	150	990	93,3	0,86	197,9	6	1062	1,9	2,7	997
7T1 315LB6	132	180	990	93,5	0,87	234,2	5,8	1274	2	2,7	1103
7T1 355MA6	160	220	990	93,8	0,87	283,0	6,3	1544	1,6	2,8	1554
7T1 355MB6	200	270	990	94,0	0,88	349,0	6,6	1930	2	2,9	1768
7T1 355L6	250	340	990	94,0	0,89	431,3	6,5	2413	1,6	3	1902
7T1 355LX6	315	430	990	94,0	0,86	562,4	5,8	3039	1,6	2,6	2480
7T1 355LXB6	355	480	990	94,0	0,86	633,9	5,8	3425	1,6	2,6	2590
7T1 400M6	355	480	990	94,0	0,86	633,9	5,8	3425	1,6	2,6	2780
7T1 400L6	400	535	990	94,0	0,86	714,2	5,8	3859	1,6	2,6	2860
7T1 450MA6	450	600	990	94,0	0,86	803,5	5,8	4341	1,6	2,6	3280
7T1 450MB6	500	670	990	94,0	0,86	892,8	5,8	4823	1,6	2,6	3380
7T1 450MC6	560	750	990	94,0	0,86	999,9	5,8	5402	1,6	2,6	3460
7T1 450L6	630	840	990	94,0	0,86	1124,9	5,8	6077	1,6	2,6	3520

Datele tehnice si caracteristicile pot fi supuse modificarilor / Technical data and performances may change

4. Performanta si date tehnice

8 POLI / 8 POLES IE1 750rpm											
Type	kW	hp	rpm	$\eta\%$ 100% load	cos φ	I _n (A) 400V 50Hz	I _s I _n	C _n (Nm)	C _s C _n	C _{max} C _n	kg
6T1 71A8	0,09	0,12	680	48,0	0,56	0,5	3	1,26	1,5	1,7	5,6
6T1 71B8	0,12	0,16	690	51,0	0,59	0,6	2,7	1,66	1,6	1,7	6
6T1 80A8	0,18	0,25	690	55,0	0,58	0,8	3	2,49	2,2	2,4	8,3
6T1 80B8	0,25	0,3	690	58,5	0,58	1,1	3,1	3,46	2,3	2,4	9,3
6T1 90S8	0,37	0,5	710	64,0	0,59	1,4	3,3	4,98	1,9	2,3	11,38
6T1 90L8	0,55	0,75	705	65,0	0,58	2,1	3,4	7,45	1,9	2,3	13,94
6T1 90LB8	0,75	1	700	69,0	0,61	2,6	3,5	10,23	1,8	2,1	15,5
6T1 100LA8	0,75	1	685	68,5	0,65	2,4	3,6	10,46	1,9	1,8	17,6
6T1 100LB8	1,1	1,5	690	72,0	0,66	3,3	3,5	15,22	1,9	2,1	20
6T1 112M8	1,5	2	700	76,0	0,66	4,3	4	20,46	1,8	2,3	25,3
6T1 132S8	2,2	3	715	79,0	0,69	5,8	4,9	29,38	1,9	2,4	39,6
6T1 132M8	3	4	715	81,0	0,7	7,6	5,1	40,07	2	2,5	47,4
7T1 160MA8	4	5,5	720	79,2	0,73	10	4,4	53,1	2,2	2,5	90
7T1 160MB8	5,5	7,5	720	81,4	0,74	13,2	5	73	2,2	2,4	102
7T1 160L8	7,5	10	720	83,1	0,75	17,4	5,7	99,5	2,1	2,3	122
7T1 180L8	11	15	720	85	0,75	24,9	5,6	144	2,3	2,5	150
7T1 200L8	15	20	730	86,2	0,76	33	5,5	196,3	2,1	2,4	212
7T1 225S8	18,5	25	730	86,9	0,76	40,4	5,6	242,1	2,2	2,6	285
7T1 225M8	22	30	740	87,4	0,78	46,6	5,4	284	2,1	2,4	385
7T1 250M8	30	40	740	88,3	0,79	62,1	5,3	387,3	2,2	2,5	378
7T1 280S8	37	50	740	88,8	0,79	76,1	5,6	477,7	2,3	2,7	485
7T1 280M8	45	60	740	89,2	0,79	92,2	5,2	581	2,1	2,8	568
7T1 315S8	55	75	740	89,7	0,81	109,3	5,7	710,1	1,9	2,5	745
7T1 315M8	75	100	740	90,3	0,81	148,0	5,9	968,3	2,1	2,8	805
7T1 315LA8	90	125	740	90,7	0,82	174,7	6,2	1162	2,3	2,9	998
7T1 315LB8	110	150	740	91,1	0,82	212,5	6	1420	2,2	2,8	1175
7T1 355MA8	132	180	740	91,5	0,82	246,4	6,4	1704	1,9	2,7	1556
7T1 355MB8	160	220	740	91,9	0,82	298	6,3	2066	1,7	2,6	1704
7T1 355LA8	200	270	740	92,5	0,83	366,9	6,5	2582	1,8	2,9	1989
7T1 355LB8	250	340	740	92,5	0,82	475,7	5,5	3226	1,5	2,6	2450
7T1 355LX8	280	380	740	92,5	0,82	532,6	5,5	3614	1,5	2,6	2560
7T1 400L8	315	430	740	92,5	0,82	599,4	5,5	4065	1,5	2,6	2840
7T1 450LA8	355	480	740	92,5	0,82	675,6	5,5	4581	1,5	2,6	3250
7T1 450LB8	400	535	740	92,5	0,82	761,2	5,5	5162	1,5	2,6	3370
7T1 450LC8	450	600	740	92,5	0,82	856,3	5,5	5807	1,5	2,6	3460

Datele tehnice si caracteristicile pot fi supuse modificarilor / Technical data and performances may change

4.4 Motoare trifazate cu doua viteze / Three-phase double speed motors

2/4 POLI / 2/4 POLES 3000 / 1500rpm Conexiune Dahlander cu cuplu constant / constant torque Dahlander connection												
Type	kW	hp	rpm	$\eta\%$ 100%	cos ϕ	In (2p)	In (4p)	Is/In (2p)	Is/In (4p)	Cs/Cn (2p)	Cs/Cn (4p)	kg
6P 71A	0.30/0.22	0.41/0.3	2760/1410	68/69	0.90/0.82	1.3	0.9	3.2	3	1.7	1.8	6
6P 71B	0.45/0.3	0.61/0.41	2720/1390	68/69	0.90/0.82	1.6	1.1	3.7	3.5	2	2	6.1
6P 80A	0.59/0.44	0.8/0.6	2730/1390	70/71	0.91/0.84	1.8	1.3	3.8	4	2	2	10
6P 80B	0.81/0.59	1.1/0.8	2800/1420	72/73	0.91/0.94	2.6	2	5	4	2	2	11
6P 90S	1.32/1	1.8/1.36	2770/1380	69/67	0.91/0.80	3.7	2.65	3.8	3.8	1.8	1.7	13
6P 90L	2/1.32	2.7/1.8	2780/1380	72/70	0.91/0.79	4.7	3.5	4	4.2	2	1.8	14
6P 100LA	2.4/1.8	3.2/2.4	2880/1420	77/79	0.90/0.82	5.9	4.5	4.4	4.6	2.2	2	21
6P 100LB	3.1/2.4	4.2/3.3	2860/1400	79/80	0.90/0.84	8.3	6.1	5	5.2	2.2	2.1	24
6P 112M	4.2/3.2	5.7/4.3	2900/1430	80/83	0.93/0.87	11	7.5	5.5	5.5	2.2	2.1	28
6P 132S	5.5/4.5	7.5/6.1	2900/1450	77.5/81.5	0.93/0.89	11.5	9.5	6.5	6	2.3	2.2	42
6P 132M	7.5/6.2	10.2/8.4	2910/1450	81/83	0.93/0.89	17	13.5	7	6	2.3	2.2	51
6P 132MA	9.5/7.5	13/10	2910/1450	81/84	0.93/0.90	20	16	7	6	2.3	2.2	54
7P 160M	11/8.8	15/12	2930/1460	81/88	0.90/0.86	24	20	7.3	6	2.3	2.2	118
7P 160L	15/11.8	20/16	2930/1460	87/89	0.93/0.98	30	26	8	7	1.8	2.2	130
7P 180M	18.5/15	25/20	2930/1460	87/88	0.91/0.89	36.2	30	8	7.6	2.5	2.4	165
7P 180L	22/18.5	30/25	2950/1460	86/87	0.90/0.91	43	37.2	8	7.8	2	2	181
7P 200L	30/22	40/30	2930/1460	86/87	0.93/0.91	57	44	6.8	6.7	2	1.8	245
7P 225S	38/32	51.7/43.5	2930/1460	87/89	0.91/0.89	70	60	6.8	6.7	2	1.8	258
7P 225M	45/38	60/51.7	2930/1460	87/88	0.93/0.89	84	64	6.8	6.7	2	1.8	290
7P 250M	55/45	75/60	2940/1465	87/88	0.90/0.87	100	76	7	6.5	2.1	1.7	388
7P 280S	70/55	95/75	2945/1470	87/88	0.90/0.89	128	100	6.9	6.4	2	1.7	510
7P 280M	85/70	116/95	2945/1470	87/88	0.91/0.89	148	131	6.9	6.3	2	1.7	606

2/4 POLI / 2/4 POLES 3000 / 1500rpm conexiune Dahlander cu cuplu patrat / quadratic torque Dahlander connection												
Type	kW	hp	rpm	$\eta\%$ 100%	cos ϕ	In (2p)	In (4p)	Is/In (2p)	Is/In (4p)	Cs/Cn (2p)	Cs/Cn (4p)	kg
6V 71A	0.35/0.08	0.48/0.12	2760/1400	68/72	0.90/0.82	1.3	0.34	3.5	3	1.8	1.8	6
6V 71B	0.51/0.12	0.7/0.16	2720/1390	69/73	0.91/0.90	1.6	0.45	4	3.5	2	2	6.1
6V 80A	0.7/0.15	0.95/0.2	2730/1390	68/73	0.90/0.82	1.8	0.5	4	3.5	1.9	1.9	10
6V 80B	0.96/0.25	1.3/0.34	2800/1410	71/76	0.90/0.84	2.6	0.7	4.5	3.5	1.9	2	11
6V 90S	1.4/0.33	1.9/0.45	2770/1400	67/69	0.93/0.86	4.2	0.8	4.5	3.9	2	1.9	13
6V 90L	2/0.5	2.7/0.68	2780/1400	72/72	0.94/0.85	5.2	1.15	4.7	4	2	1.9	14
6V 100LA	2.4/0.65	3.3/0.88	2880/1410	77/79	0.93/0.87	6.2	1.5	4.9	4	2.2	1.6	21
6V 100LB	3.1/0.81	4.2/1.1	2860/1440	79/80.5	0.92/0.86	8.3	1.8	5	4.9	2.2	1.8	24
6V 112M	4.4/1.1	6/1.5	2900/1450	80/80	0.93/0.89	12	2.5	5.6	4.9	2.2	1.6	28
6V 132S	5.9/1.5	8/2	2900/1450	78.5/83	0.92/0.88	13	3.2	6.8	5.2	2.3	2.1	42
6V 132M	8/2	10.9/2.7	2910/1450	81/84	0.93/0.89	17	4.2	7	5.8	2.3	2.2	51
6V 132MA	10.3/2.6	14/3.5	2910/1450	81/83	0.93/0.89	18.5	5.5	7.1	5.8	2.4	2	54
7V 160M	11.5/3	15.6/4	2930/1465	88/83	0.88/0.91	24	6	7.2	5.8	2.4	2.1	118
7V 160L	15.4/3.8	21/5.2	2935/1465	89/86	0.93/0.91	30	7.5	8	6.5	2.4	2.2	130
7V 180M	20/5	27/6.8	2930/1460	89/86	0.88/0.91	39	10	8	7.5	2.5	2.4	165
7V 180L	24/6	33/8.2	2950/1470	88/87	0.89/0.90	48	11	8	7.5	2.6	2.5	181
7V 200L	30/7.5	40/10	2930/1460	87/88	0.90/0.91	57	16	6.6	6.4	2	1.8	245
7V 225S	38/9	51.7/12.2	2930/1460	87/89	0.91/0.89	70	18	6.8	6.6	2	1.8	258
7V 225M	45/11	60/15	2930/1460	87/88	0.93/0.89	84	22	6.8	6.6	2	1.8	290
7V 250M	55/13.5	75/18.4	2940/1465	87/88	0.90/0.87	100	27	7	6.4	2.1	1.7	388
7V 280S	70/16	95.2/21.8	2945/1470	87/88	0.90/0.88	128	31	6.9	6.3	2	1.7	510
7V 280M	85/19	115/25.8	2945/1470	87/89	0.91/0.90	147	37	6.9	6.2	2	1.7	606

Datele tehnice si caracteristicile pot fi supuse modificarilor / Technical data and performances may change

4. Performanta si date tehnice

4/8 POLI / 4/8 POLES 1500 / 750rpm
Conexiune Dahlander cu cuplu constant / constant torque Dahlander connection

Type	kW	hp	rpm	$\eta\%$ 100%	$\cos\varphi$	I_n (4p)	I_n (8p)	I_s/I_n (4p)	I_s/I_n (8p)	C_s/C_n (4p)	C_s/C_n (8p)	kg
6P 71B	0.2/0.1	0.27/0.14	1370/660	73/51	0.87/0.62	0.65	0.7	3	2.5	1.7	1.7	7
6P 80A	0.3/0.15	0.4/0.2	1350/680	74/50	0.87/0.62	1	1.1	3.5	2.5	1.7	1.9	9.5
6P 80B	0.37/0.22	0.5/0.3	1370/680	72/53	0.87/0.62	1.4	1.5	3.5	3	1.7	1.9	10
6P 90S	0.7/0.37	0.95/0.5	1350/680	72/58	0.89/0.60	1.8	1.9	3.5	3	1.7	1.8	12
6P 90L	1.03/0.55	1.4/0.75	1340/680	72/60	0.89/0.65	2.5	2.5	3.7	3	1.7	1.9	13
6P 100LA	1.25/0.7	1.7/0.95	1400/700	76/64	0.89/0.62	3.2	3	4	3	1.5	1.5	22
6P 100LB	1.6/0.88	2.2/1.2	1420/690	79/66	0.88/0.61	3.9	3.7	4.5	3	1.7	1.7	24
6P 112M	2.4/1.5	3.3/2	1370/680	81/73	0.89/0.65	5.5	4.8	4.5	3.5	1.7	1.8	26
6P 132S	3.3/2.2	4.5/3	1420/690	80/75	0.91/0.67	8	6	5	4	1.7	1.8	46
6P 132MA	4.4/3	6/4	1410/690	82/78	0.91/0.65	9.80	10.5	5.5	4	1.7	1.8	50
6P 132MB	5.5/4	7.5/5.5	1410/690	82/79	0.90/0.66	12	11	5.5	4	1.7	1.8	51
7P 160MA	7.5/4.8	10/6.5	1430/710	87/80	0.90/0.61	16.9	12.8	6	5	1.8	1.8	101
7P 160MB	8.1/5.5	11/7.5	1430/710	88/81	0.90/0.62	17.6	13.8	6	5	1.8	1.8	102
7P 160L	10.3/6.6	14/9	1450/720	87/85	0.92/0.68	21	15.3	7	5.5	2	2	103.7
7P 180M	11.8/7.5	16/10	1450/720	85/83	0.90/0.67	23.3	17	7.5	6	2	2	159
7P 180L	15/9.2	20/12.5	1450/720	86/84	0.90/0.66	29.8	21	7.5	6	2	2.1	163
7P 200LA	18.5/11.8	25/16	1455/725	86/84	0.91/0.69	37	24	6.8	5.6	2.2	2.1	226
7P 200LB	22/15	30/20	1455/725	86/84	0.91/0.70	42	36	6.8	5.6	2.2	2.1	228
7P 225S	30/19	40/26	1455/725	88/85	0.90/0.71	55	44	6.9	5.6	2.2	2.1	242
7P 225M	33.8/22	46/30	1455/725	88/85	0.90/0.71	63	52	6.8	5.5	2.1	2	265
7P 250M	40/27	55/37	1460/730	87/85	0.89/0.71	74	63	6.9	5.5	2.1	2	357
7P 280S	48/32	65/44	1460/730	89/88	0.88/0.70	87	72	7	5.7	2.3	2.1	469
7P 280M	56/38	76/52	1460/730	88/86	0.89/0.70	100	82	7	5.8	2.3	2.1	472

4/8 POLI / 4/8 POLES 1500 / 750rpm
conexiune Dahlander cu cuplu patrat / quadratic torque Dahlander connection

Type	kW	hp	rpm	$\eta\%$ 100%	$\cos\varphi$	I_n (4p)	I_n (8p)	I_s/I_n (4p)	I_s/I_n (8p)	C_s/C_n (4p)	C_s/C_n (8p)	kg
6V 71A	0.22/0.05	0.3/0.07	1380/650	68/52	0.78/0.60	0.8	0.3	3	1.8	1.4	1.2	6.5
6V 71B	0.3/0.07	0.41/0.09	1380/650	68/53	0.79/0.61	1.1	0.4	3	2	1.5	1.2	7
6V 80A	0.5/0.11	0.68/0.15	1380/685	73/55	0.80/0.60	1.5	0.6	3.5	2.5	1.6	1.6	9.5
6V 80B	0.7/0.15	0.95/0.2	1390/660	74/56	0.83/0.66	2.2	0.8	4	2.5	1.7	1.6	10
6V 90S	1/0.22	1.36/0.3	1400/690	68/62	0.83/0.70	3.2	1.3	4	2.5	1.7	1.6	12
6V 90L	1.32/0.33	1.8/0.45	1400/680	72/66	0.82/0.71	4	1.6	4.1	2.5	2	1.6	13
6V 100LA	2/0.51	2.7/0.7	1420/700	73/67	0.89/0.75	5.1	2.1	4.5	3	1.7	1.4	22
6V 100LB	2.6/0.66	3.6/0.9	1440/710	76/69	0.89/0.75	6.4	2.6	5.2	3.1	2.2	1.6	24
6V 112M	3.6/0.96	4.9/1.3	1410/710	78/75	0.86/0.70	8.5	3.5	5.5	3.1	2.2	1.6	26
6V 132S	4.5/1.1	6/1.5	1430/710	81/75	0.81/0.69	10.5	3.8	5.5	3.1	2	1.6	46
6V 132M	6.1/1.4	8.3/1.9	1440/710	81/78	0.90/0.75	13	5	6	3.5	2	1.7	50
7V 160M	9/2.2	12.2/3	1460/725	87/83	0.87/0.71	18.5	5.5	6	4	1.6	1.4	101
7V 160L	12/3	16.3/4	1430/715	87/82	0.85/0.70	26	9.30	7	4.5	2	1.6	103
7V 180M	16.2/3.7	22/5	1470/740	85/83	0.88/0.71	34	11.5	7.5	5	2	2.2	158
7V 180L	19/4.5	26/6	1470/730	86/84	0.87/0.72	39	14	7.5	5	2.5	2.2	163
7V 200L	26/6	35/8.2	1455/725	86/84	0.89/0.70	49	14	6.4	6.1	2.3	2.2	226
7V 225S	35/8.1	48/11	1455/725	87/83	0.90/0.71	66	19	6.5	6.1	2.2	2.2	242
7V 225M	42/10.3	57/14	1455/725	87/82	0.90/0.70	76	23	6.6	6	2.1	2.1	244
7V 250M	48/11.8	65/16	1460/725	88/81	0.90/0.71	87	26	6.5	6	2	2.1	356
7V 280S	63/15	86/20	1460/730	87/81	0.89/0.69	114	32	6.4	6.2	2.1	2.2	469
7V 280M	75/18.5	100/25	1460/730	84/82	0.88/0.71	133	39	6.3	6.1	2	2.1	472

Datele tehnice si caracteristicile pot fi supuse modificarilor / Technical data and performances may change

4-6 POLI / 4-6 POLES 1500 / 1000rpm infasurari separate cu cuplu constant / constant torque separate windings												
Type	kW	hp	rpm	$\eta\%$ 100%	$\cos\varphi$	I_n (4p)	I_n (6p)	I_s/I_n (4p)	I_s/I_n (6p)	C_s/C_n (4p)	C_s/C_n (6p)	kg
6P 80A	0.37/0.22	0.5/0.3	1420/920	70/59	0.84/0.74	1.3	0.97	4	3	1.8	1.8	10.5
6P 80B	0.45/0.3	0.6/0.4	1420/930	69/59	0.83/0.77	1.5	1.3	4.3	3.5	1.9	1.9	11
6P 90S	0.66/0.45	0.9/0.6	1420/930	68/59	0.85/0.79	1.9	1.8	4.1	3.1	1.8	1.5	13
6P 90L	0.95/0.59	1.3/0.8	1420/940	71/62	0.84/0.77	2.8	2.2	4.1	3.1	1.8	1.5	14.5
6P 100LA	1.32/0.88	1.8/1.2	1440/940	74/71	0.79/0.76	3.6	2.8	4.5	3.5	1.6	1.6	21
6P 100LB	1.7/1.2	2.3/1.6	1450/940	75/73	0.79/0.76	5.2	3.8	4.5	3.5	1.6	1.6	23
6P 112M	2.2/1.5	3/2	1450/950	80/75	0.80/0.72	6.5	4.5	5.3	4.2	1.6	1.6	27
6P 132S	3.4/2.4	4.7/3.2	1460/960	80/76	0.88/0.75	8	6	5.5	4.5	1.8	1.7	41
6P 132MA	4.6/3.2	6.2/4.3	1460/960	82/77	0.89/0.78	10	8.30	5.5	4.5	1.8	1.7	45
6P 132MB	5.1/3.3	7/4.5	1460/960	83/78	0.89/0.78	11	8.6	5.5	4.4	1.8	1.7	49
7P 160M	6.6/4.5	9/6	1470/970	86/83	0.89/0.81	14	11	6.4	4.6	2.1	1.9	117
7P 160L	8.8/5.9	12/8	1470/970	89/85	0.89/0.82	18.5	15	6.8	5.4	2.3	2.2	141
7P 180M	11/7.5	15/10	1470/980	86/83	0.89/0.81	23	18	6.8	5.6	2.3	2.3	170
7P 180L	13.2/8.8	18/12	1480/980	87/83	0.89/0.82	27	21	7	5.6	2.3	2.3	174
7P 200LA	18.5/13.2	25/18	1470/975	87/83	0.88/0.82	37	28	6.4	6.1	2.2	2.2	200
7P 200LB	22/15	30/20	1470/975	88/83	0.89/0.82	44	32	6.5	6.1	2.2	2.2	221
7P 225S	26/16	35/22	1470/975	88/81	0.89/0.80	49	35	6.5	6.1	2.1	2.1	255
7P 225M	30/19	40/26	1470/975	88/81	0.88/0.79	56	40	6.6	6	2	2.1	265
7P 250M	33/22	45/30	1475/980	89/83	0.89/0.82	60	47	6.5	6	2.1	2.2	362
7P 280S	40/26	55/35	1475/980	87/82	0.89/0.83	75	53	6.4	6.2	2.2	2.1	490
7P 280M	50/33	68/45	1475/980	87/82	0.89/0.83	95	71	6.3	6.1	2	2.1	540

4-6 POLI / 4-6 POLES 1500 / 1000rpm infasurari separate cu cuplu patrat / quadratic torque separate windings												
Type	kW	hp	rpm	$\eta\%$ 100%	$\cos\varphi$	I_n (4p)	I_n (6p)	I_s/I_n (4p)	I_s/I_n (6p)	C_s/C_n (4p)	C_s/C_n (6p)	kg
6V 71A	0.15/0.08	0.2/0.1	1350/660	70/60	0.84/0.71	0.52	0.35	3.3	2.4	1.7	1.3	6
6V 71B	0.26/0.09	0.35/0.13	1360/660	70/60	0.84/0.71	0.89	0.4	3.3	2.4	1.7	1.3	6.3
6V 80A	0.37/0.12	0.5/0.16	1420/950	70/59	0.84/0.74	1.3	0.53	3.8	2.5	1.9	1.4	10.5
6V 80B	0.55/0.18	0.75/0.25	1420/935	69/59	0.83/0.77	1.4	1.2	4	3	1.9	1.5	12
6V 90S	0.81/0.28	1.1/0.38	1420/950	68/59	0.85/0.79	1.8	1.5	3.8	2.8	1.8	1.5	13
6V 90L	1.1/0.37	1.5/0.5	1420/950	71/62	0.84/0.77	2.4	1.3	3.6	2.9	1.7	1.6	18
6V 100LA	1.7/0.6	2.3/0.82	1430/950	74/71	0.79/0.77	3.9	2.2	4.7	3.3	1.9	1.6	25
6V 100LB	2.2/0.75	3/1	1430/950	75/73	0.79/0.76	4.8	2.6	4.8	3	2.2	1.5	25
6V 112M	3/0.9	4/1.2	1440/970	80/75	0.80/0.74	6.3	3.5	4.7	3.5	2.2	1.6	31
6V 132S	4.2/1.4	5.7/1.9	1450/970	80/76	0.88/0.75	8.4	4	5.8	4.8	2.2	1.6	45
6V 132MA	5/1.7	6.8/2.3	1450/970	82/77	0.89/0.78	9.9	4.9	7	4.4	2.2	1.6	53
6V 132MB	5.9/2	8/2.7	1450/970	83/78	0.88/0.77	11.6	5.8	6.5	4.8	2.2	1.6	54
7V 160M	7.5/2.5	10/3.4	1460/980	86/83	0.89/0.81	14.6	6.2	6	5	2	1.6	118
7V 160L	11/3.7	15/5	1465/980	89/85	0.89/0.82	21.2	8.30	6.5	5.5	2.2	1.9	120
7V 180M	15/5.2	20/7.1	1470/985	86/83	0.88/0.80	28.4	12.5	6.6	5.8	2.4	2.2	176
7V 180L	18/6.2	24.5/8.4	1465/985	87/83	0.89/0.82	32.6	13.1	6.8	5.8	2.4	2.2	180
7V 200L	25/9	34/12.2	1475/985	87/83	0.89/0.82	45.6	17.6	6.4	6.1	2.2	2.2	258
7V 225S	30/11	40/15	1470/980	88/81	0.89/0.83	65	23	6.5	6.1	2.2	2.2	312
7V 225M	37/14	50/19	1470/980	88/81	0.88/0.79	79	28	6.6	6	2.1	2.1	346
7V 250M	50/17.5	68/23.8	1470/980	89/83	0.89/0.82	95	36	6.5	6	2	2.1	362
7V 280S	60/20	81.6/27.2	1470/985	87/82	0.88/0.83	114	43	6.4	6.2	2.1	2.2	490
7V 280M	75/25	100/34	1470/985	87/82	0.89/0.83	142	52	6.3	6.1	2	2.1	540

Datele tehnice si caracteristicile pot fi supuse modificarilor / Technical data and performances may change

4. Performanta si date tehnice

6-8 POLI / 6-8 POLES 1000-750rpm infasurari separate cu cuplu constant / constant torque separate windings

Type	kW	hp	rpm	$\eta\%$ 100%	cos ϕ	In (6p)	In (8p)	Is/In (6p)	Is/In (8p)	Cs/Cn (6p)	Cs/Cn (8p)	kg
6P 80A	0.18/0.13	0.25/0.18	920/630	56/51	0.76/0.69	0.78	0.65	2.7	2	1.5	1.8	8.69
6P 80B	0.26/0.15	0.35/0.2	920/630	57/51	0.76/0.69	1.12	0.75	2.7	2	1.5	1.8	10.5
6P 90S	0.37/0.28	0.5/0.38	930/690	57/50	0.77/0.70	1.6	1.4	3	3	1.5	1.8	12
6P 90L	0.59/0.3	0.8/0.4	930/700	62/53	0.74/0.68	2.15	1.5	3.3	3	1.5	1.8	13.7
6P 100LA	0.81/0.55	1.1/0.75	950/700	67/55	0.77/0.63	2.7	2.1	3.8	3.3	1.5	1.8	22
6P 100LB	1.03/0.66	1.4/0.9	950/700	68/56	0.76/0.64	3.3	2.5	3.8	3.3	1.5	1.8	24
6P 112M	1.4/1.03	1.9/1.4	960/705	71/55	0.74/0.66	4.4	3.6	4.5	4	1.5	1.8	27
6P 132S	1.84/1.32	2.5/1.8	970/720	78/70	0.72/0.67	5.2	4	5	4.5	1.7	1.9	43
6P 132MA	2.6/1.84	3.5/2.5	975/725	78/70	0.72/0.66	7.4	5.7	5.5	4.5	2	1.9	54
6P 132MB	3/2	4/2.7	975/725	78/71	0.72/0.67	8.5	6	5.3	5	2	1.9	59
7P 160M	4/2.6	5.5/3.5	980/730	79/71	0.74/0.69	11	7.5	6.5	5.1	1.8	1.9	104
7P 160L	5.5/4	7.5/5.5	980/730	79/71	0.73/0.69	13	10	6.8	5.1	1.8	1.8	112
7P 180M	6.6/5.1	9/7	950/720	79/72	0.70/0.69	16	13.5	6.8	5.5	1.7	1.8	144
7P 180L	8.1/5.9	11/8	950/720	79/72	0.70/0.69	18	15	6.8	5.5	1.7	1.8	159
7P 200LA	11/8.1	15/11	980/730	78/71	0.71/0.68	23	18	6	5.6	1.8	1.8	170
7P 200LB	13.2/9.5	18/13	980/730	78/71	0.71/0.68	30	24	6	5.6	1.8	1.8	227
7P 225S	16/13.2	22/18	980/730	77/71	0.73/0.69	35	30	5.9	5.5	1.7	1.7	233
7P 225M	22/17	30/23	980/730	77/72	0.73/0.69	46	38	5.8	5.4	1.7	1.7	241
7P 250M	30/22	40/30	980/730	78/74	0.72/0.68	65	50	6.1	5.6	1.8	1.8	366
7P 280S	35/26	48/36	980/735	79/73	0.72/0.68	76	58	6	5.4	1.7	1.7	470
7P 280M	41/33	56/45	980/735	79/73	0.74/0.67	82	74	6.1	5.5	1.7	1.8	536

6-8 POLI / 6-8 POLES 1000-750rpm infasurari separate cu cuplu patrat / quadratic torque separate windings

Type	kW	hp	rpm	$\eta\%$ 100%	cos ϕ	In (6p)	In (8p)	Is/In (6p)	Is/In (8p)	Cs/Cn (6p)	Cs/Cn (8p)	kg
6V 80A	0.25/0.09	0.34/0.12	920/720	56/51	0.76/0.69	1	0.5	3.5	3	1.6	1.8	9
6V 80B	0.37/0.15	0.5/0.20	930/710	57/51	0.76/0.69	1.3	0.8	3.5	3	1.8	1.8	10
6V 90S	0.55/0.2	0.75/0.27	930/710	57/50	0.77/0.70	2	1.1	3.5	3	1.8	1.8	12
6V 90L	0.75/0.3	1/0.4	930/700	62/53	0.74/0.68	2.6	1.5	3.5	3	1.8	1.8	13
6V 100L	1/0.4	1.36/0.54	950/710	67/55	0.77/0.63	3.4	1.4	4.3	3.4	1.7	1.8	22
6V 112M	1.4/0.6	1.9/0.81	960/710	71/55	0.74/0.66	4.1	2.3	4.9	3.5	2	1.5	27
6V 132S	2.2/0.9	3/1.2	970/720	78/70	0.72/0.67	5.8	2.8	5.5	4	2	1.5	44
6V 132MA	2.8/1.1	3.8/1.5	975/730	78/70	0.72/0.66	7.7	3.7	5.5	4.3	2	1.8	54
6V 132MB	3.5/1.5	4.8/2	975/730	78/71	0.72/0.67	10	4.6	6	4.5	2.2	1.9	59
7V 160M	5.5/2.6	7.5/3.5	975/730	79/70	0.74/0.69	13	7.3	6	4.5	2	1.7	104
7V 160L	8/3	10.8/4	980/740	79/70	0.73/0.69	19	8.6	6.5	5	2	1.7	114
7V 180M	9.5/4	13/5.5	975/730	79/72	0.70/0.69	21	11	7	5.5	2	1.7	144
7V 180L	11/5	15/6.8	970/740	79/72	0.70/0.69	23	14	7	5.5	2	1.7	159
7V 200LA	12/6.5	16/8.8	975/735	78/71	0.71/0.68	28	16	5.6	5.4	2	1.9	169
7V 200LB	14/8	19/10.8	975/735	78/71	0.71/0.68	32	19	5.6	5.4	2	1.9	227
7V 225S	18/8.5	24.5/11.6	975/735	77/71	0.73/0.69	38	22	5.6	5.4	2	1.9	234
7V 225M	25/11	34/15	975/735	77/72	0.73/0.69	50	27	5.6	5.4	1.8	1.9	241
7V 250M	30/14	40/19	975/735	78/73	0.72/0.69	60	35	5.5	5.5	1.9	2	367
7V 280S	37/17	50/23	980/740	79/74	0.72/0.68	75	40	5.6	5.4	1.8	1.8	471
7V 280M	45/20	60/27	980/740	79/74	0.73/0.68	85	48	5.6	5.4	1.8	1.8	537

Datele tehnice si caracteristicile pot fi supuse modificarilor / Technical data and performances may change

◆ 4.5 Motoare monofazate / Single phase motors

2 POLI / 2 POLES 6M 3000rpm condensator de functionare / run capacitor												
Type	kW	hp	rpm	$\eta\%$	$\cos\varphi$	I_n	I_s/I_n	C_n	C_s/C_n	C_{max}/C_n	Run Cap. (μF)	kg
6M 56A2	0,09	0,12	2760	54,00	0,90	0,805	3,73	0,31	0,7	1,6	4	2,9
6M 56B2	0,12	0,16	2770	58,00	0,92	0,978	4,09	0,41	0,7	1,6	6	3,2
6M 63A2	0,18	0,25	2780	60,00	0,92	1,418	4,94	0,62	0,7	1,7	10	4
6M 63B2	0,25	0,34	2780	61,00	0,92	1,937	5,16	0,86	0,68	1,7	12	4,5
6M 63C2	0,37	0,5	2740	68,00	0,99	2,390	3,50	1,29	0,7	1,8	16	5,3
6M 71A2	0,37	0,5	2800	63,00	0,93	2,746	4,37	1,26	0,65	1,7	20	5,1
6M 71B2	0,55	0,75	2800	68,00	0,93	3,781	3,97	1,88	0,65	1,7	25	7,2
6M 71C2	0,75	1	2540	67,00	0,98	4,970	3,00	2,82	0,67	1,55	30	8,2
6M 80A2	0,75	1	2810	69,00	0,94	5,028	3,98	2,55	0,65	1,7	30	9,6
6M 80B2	1,1	1,5	2820	70,00	0,94	7,268	3,85	3,73	0,65	1,7	40	11
6M 80C2	1,84	2,5	2710	62,50	0,99	12,900	3,00	6,48	0,75	1,67	55	13,1
6M 90S2	1,5	2	2820	71,00	0,94	9,772	4,09	5,08	0,65	1,8	50	14
6M 90L2	2,2	3	2820	74,00	0,94	13,751	4,36	7,45	0,65	1,8	60	16,5
6M 100L2	3	4	2840	75,00	0,94	18,501	4,05	10,09	0,6	1,8	90	25

4 POLI / 4 POLES 6M 1500rpm condensator de functionare / run capacitor												
Type	kW	hp	rpm	$\eta\%$	$\cos\varphi$	I_n	I_s/I_n	C_n	C_s/C_n	C_{max}/C_n	Run Cap. (μF)	kg
6M 56A4	0,06	0,08	1360	48,00	0,92	0,591	4,23	0,42	0,75	1,6	4	3,5
6M 56B4	0,09	0,12	1370	51,00	0,92	0,834	3,60	0,63	0,75	1,6	6	3,8
6M 63A4	0,12	0,16	1380	52,00	0,92	1,091	3,21	0,83	0,65	1,6	10	4
6M 63B4	0,18	0,25	1390	55,00	0,92	1,547	3,56	1,24	0,65	1,5	12	4,6
6M 63C4	0,25	0,34	1380	62,50	0,99	1,760	2,60	1,73	0,63	1,57	14	5,4
6M 71A4	0,25	0,34	1380	51,00	0,92	2,317	3,45	1,73	0,75	1,5	20	6,7
6M 71B4	0,37	0,5	1390	55,00	0,90	3,250	3,08	2,54	0,67	1,5	25	8,2
6M 71C4	0,55	0,75	1385	70,00	0,99	3,450	3,04	3,79	0,45	1,47	20	8,4
6M 80A4	0,55	0,75	1360	63,00	0,94	4,038	3,71	3,86	0,7	1,7	25	9,2
6M 80B4	0,75	1	1360	65,00	0,94	5,337	3,75	5,27	0,68	1,7	35	9
6M 80C4	0,9	1,2	1345	68,50	0,97	5,890	4,00	6,39	0,64	1,69	40	10,3
6M 90S4	1,1	1,5	1360	70,00	0,94	7,268	4,13	7,72	0,65	1,8	45	14,5
6M 90L4	1,5	2	1360	72,00	0,94	9,636	4,15	10,53	0,62	1,8	55	16,2
6M 90LA4	1,84	2,5	1360	76,00	0,99	10,600	4,00	12,92	0,69	1,8	70	19,1
6M 100LA4	1,84	2,5	1380	76,00	0,97	10,900	4,00	12,73	0,45	1,6	60	20
6M 100LB4	2,2	3	1400	68,00	0,90	15,629	3,84	15,01	0,67	1,8	110	24,5
6M 100LC4	3	4	1400	76,00	0,94	18,258	4,11	20,46	0,48	1,8	100	30

Datele tehnice si caracteristicile pot fi supuse modificarilor / Technical data and performances may change

4. Performanta si date tehnice

2 POLI / 2 POLES 6L 3000rpm intrerupator centrifugal / centrifugal switch													
Type	kW	hp	rpm	$\eta\%$	cos ϕ	In	Is/In	Cn	Cs/Cn	Cmax/Cn	Run Cap. (μ F)	Start Cap. (μ F)	kg
6L 63A2	0,18	0,25	2710	63	0,9	1,38	5,80	0,63	2,5	1,6	10	30	4,2
6L 63B2	0,25	0,34	2710	64	0,9	1,89	5,29	0,88	2,5	1,6	12	40	4,7
6L 71A2	0,37	0,5	2780	65	0,93	2,66	5,64	1,27	2,5	1,8	12	75	5,3
6L 71B2	0,55	0,75	2790	68	0,93	3,78	5,29	1,88	2,5	1,8	16	100	7,4
6L 80A2	0,75	1	2800	72	0,93	4,87	6,16	2,56	2,5	1,8	20	100	9,5
6L 80B2	1,1	1,5	2810	73	0,93	7,04	5,68	3,74	2,5	1,8	30	150	11,2
6L 90S2	1,5	2	2810	74	0,93	9,48	5,80	5,1	2,5	1,8	40	200	14
6L 90L2	2,2	3	2810	75	0,94	13,57	5,53	7,48	2,5	1,8	50	250	17
6L 100L2	3	4	2830	77	0,95	17,83	6,17	10,13	2,5	1,7	60	400	25
6L 112MA2	3,7	5	2850	78	0,96	21,48	6,52	12,4	2,5	1,7	60	600	30,5
6L 112MB2	4	5,5	2850	80	0,98	22,18	6,76	13,41	2,5	1,7	60	600	31,5

4 POLI / 4 POLES 6L 1500rpm intrerupator centrifugal / centrifugal switch													
Type	kW	hp	rpm	$\eta\%$	cos ϕ	In	Is/In	Cn	Cs/Cn	Cmax/Cn	Run Cap. (μ F)	Start Cap. (μ F)	kg
6L 63A4	0,12	0,16	1350	55	0,9	1,05	5,71	0,85	2,5	1,6	10	30	4,1
6L 63B4	0,18	0,25	1350	56	0,9	1,55	5,48	1,27	2,5	1,6	12	40	4,4
6L 71A4	0,25	0,34	1380	60	0,9	2,01	4,98	1,73	2,5	1,7	12	50	5,9
6L 71B4	0,37	0,5	1380	63	0,9	2,84	5,28	2,56	2,5	1,7	16	75	6,9
6L 80A4	0,55	0,75	1400	66	0,9	4,03	4,96	3,75	2,5	1,8	20	100	9,6
6L 80B4	0,75	1	1410	69	0,9	5,25	5,71	5,08	2,5	1,8	25	100	10,8
6L 90S4	1,1	1,5	1410	71	0,93	7,24	5,52	7,45	2,5	1,8	35	150	13,5
6L 90L4	1,5	2	1400	73	0,93	9,61	5,72	10,24	2,5	1,8	40	200	16,5
6L 100LA4	2,2	3	1430	74	0,93	13,9	5,40	14,7	2,5	1,8	50	300	24
6L 100LB4	3	4	1440	75	0,93	18,7	5,88	19,91	2,5	1,8	60	500	30
6L 112MA4	3,7	5	1440	77	0,95	21,99	6,37	24,55	2,5	1,7	60	600	36
6L 112MB4	4	5,5	1440	80	0,97	22,41	6,69	26,54	2,5	1,7	60	600	37,5

Datele tehnice si caracteristicile pot fi supuse modificarilor / Technical data and performances may change

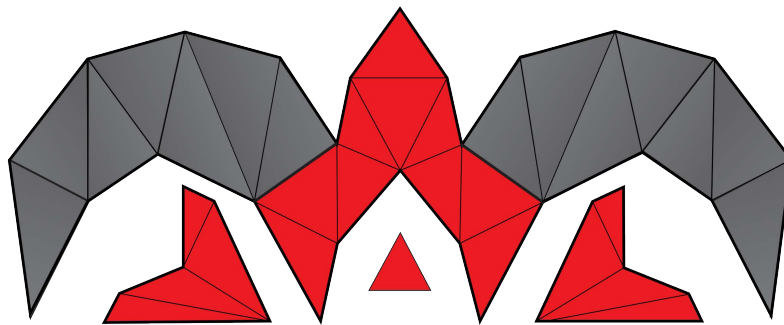

ALL INDUSTRIAL

5.0 Motoare electrice cu frana Brake motors

◆ 5.1 Alegerea franei

Alegerea franei in functie de cuplul de franare C_f necesar pentru o anumita aplicatie depinde de cunoasterea datelor de proiectare. Aceste date sunt urmatoarele:

- 1) Inertia totala J_{tot} (kgm^2) a pieselor rotative redusa la arborele cotit;
- 2) Turatia maxima de rotatie a motorului n (rotatii pe minut);
- 3) Timpul maxim admis de franare t_f (secunde);
- 4) Cuplul care actioneaza asupra sistemului CL (Nm), care poate fi reprezentat, de exemplu, printr-o sarcina care trebuie ridicata sau un moment rezistent;
- 5) Frecventa de actionare a franei, adica numarul de actionari ale franei efectuate pe ora (m /h).

Pe langa acestea, alte date, cum ar fi temperatura ambianta medie, conditiile specifice de mediu (de exemplu, umiditate, praf etc.) si pozitia de montare a motorului, sunt utile in determinarea celui mai eficient mod de functionare a franei.

Criterii de selectie

Pentru definirea cuplului de franare, au fost identificate patru cazuri care apar cel mai frecvent:

- A) Ridicarea unei greutati P (N) cu un moment CL fata de axa de rotatie;
- B) Coborarea unei greutati P (N) cu un moment CL fata de axa de rotatie;
- C) Cuplu rezistent constant CL (Nm) care se opune rotatiei motorului;
- D) Cuplu rezistent constant CL (Nm) care favorizeaza rotatia motorului.

Formulele utilizate calculeaza mai multe marimi necesare pentru verificarea aplicatiei, in conformitate cu tabelele si graficele prezentate in paginile catalogului. Aceste formule sunt:

S Coeficientul de siguranta (trebuie sa fie $S \geq 2$);

C_t Coeficientul de reducere a timpului de declansare (medie 0,995);

L Lucrul mecanic per manevra (Jouli) care trebuie disipat sub forma de caldura de catre frana.

Brake selection

The choice of brake in terms of brake torque C_f necessary for a given application is subordinate to knowledge of the project data.

Said data refers to the following:

- 1) Total inertia J_{tot} (Kgm^2) of the rotating parts reduced with respect to the motor shaft;
- 2) Maximum number of motor revolutions n (rpm);
- 3) Maximum brake time (seconds);
- 4) Torque CL (Nm) acting on the system, which may be represented, for example, by a load being lifted or by a moment of resistance;
- 5) Operating frequency of the brake, or the number of manoeuvres made by the brake in one hour m (1/h).

In addition, other data such as the mean environmental temperature, specific environmental conditions (e.g. humidity, dust etc.) and the motor mounting position, are useful in determining the most efficient way of operating the brake.

Selection criteria

Four of the most frequently occurring cases have been identified to define the brake torque:

- A) Lifting a load P (N) with a CL moment with respect to the rotation axis;
- B) Lowering a load P (N) with a CL moment with respect to the rotation axis;
- C) Constant resistant torque CL (Nm) which opposes motor rotation;
- D) Constant resistant torque CL (Nm) which favours motor rotation. In the formulas used, certain quantities are calculated, which are needed to check the application as per the tables and graphs in the catalogue. These formulas are:
 S safety coefficient (must be $S \geq 2$);
 C_t intervention time reduction coefficient (equal to 0.995 on average);
 L work per operation (Joule) which must be dissipated in heat by the brake.

Calcularea cuplului de franare necesar

Cuplul de franare necesar se calculeaza folosind formulele de mai jos. Inmultirea rezultatului acestor formule cu factorul de siguranta S, in general egal cu 2, produce cuplul de franare dorit. Graficul prezinta tipul de frana care aproximeaza valoarea obtinuta prin exces.

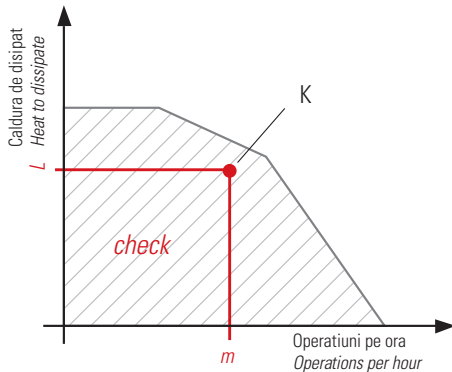

Verificarea disipatiei termice

In timpul franarii, se genereaza o anumita cantitate de caldura care trebuie disipata de frana. Prin urmare, este necesar sa se asigure ca aceasta cantitate de caldura este compatibila cu numarul de cicluri de franare pe ora. Pentru a calcula energia (L) care trebuie disipata, se utilizeaza urmatoarele formule:

Cunoscand numarul de cicluri pe ora care trebuie efectuate, se introduce graficul si se verifica daca punctul K este sub curba limita pentru tipul de frana selectat. Daca nu este cazul, se trece la o „liniuta” superioara si se repeta operatiunea.

Formula 4 (cazul A) / Formula 4 (case A)

$$L = \frac{J_{TOT} (2\pi n / 60)^2}{2} \times \left(\frac{C_f}{C_f + C_i} \right)$$

Formula 5 (cazul B) / Formula 5 (case B)

$$L = \frac{J_{TOT} (2\pi n / 60)^2}{2} \times \left(\frac{C_f}{C_f + C_i} \right)$$

Estimare aproximativa a cuplului de franare

Cunoscand doar puterea motorului exprimata in wati (W) si numarul maxim de rotatii (n), cuplul de franare necesar (Cf) poate fi calculat aproximativ cu urmatoarea formula:

$$C_f = \frac{W}{(2\pi n / 60)} \times S$$

Daca nu este posibil sa se controleze disiparea caldurii, factorul de siguranta S trebuie selectat cu atentie in functie de aplicatia necesara.

Calculation of brake torque

The formulas below can be used to calculate the brake torque needed. By multiplying the results of these formulas by the safety coefficient S, generally equal to 2, the desired brake torque is obtained. The graph indicates the type of brake, with the value rounded up.

Formula 1 (aproximativ A si C) / Formula 1 (cases A e C)

$$C_{fc} = \frac{(2\pi n / 60) \times J_{TOT}}{tr \times C_t} - (C_i)$$

Formula 2 (cazurile B si D) / Formula 2 (cases B e D)

$$C_{fc} = \frac{(2\pi n / 60) \times J_{TOT}}{tr \times C_t} + (C_i)$$

Formula 3 / Formula 3

$$C_f = C_{fc} \times S$$

Heat dissipation test

During brake, a quantity of heat is generated which must be dissipated by the brake. It is therefore important to check that this quantity of heat is compatible with the number of operations/hour the brake needs to make. To calculate the value of the energy (L) that needs to be dissipated, use the following formulas: Knowing the number of operations/hour the brake needs to make, enter the graph and check that point K is below the limit curve for the selected brake type. If this is not the case, move up to the next “dash” and repeat the operation.

Formula 6 (cazurile C si D) / Formula 6 (cases C e D)

$$L = \frac{J_{TOT} (2\pi n / 60)^2}{2}$$

Approximate calculation of brake torque

Knowing only the motor output expressed in Watt (W) and the maximum number of revolutions (n), the necessary brake torque (Cf) can be roughly calculated using the following formula:

$$C_f = \frac{W}{(2\pi n / 60)} \times S$$

If it is not possible to check the heat dissipation, the safety coefficient S must be selected using criteria based on the requested application.

◆ 5.2 Redresoare

Motoarele cu frana de curent continuu (seriile S, K, H și R) sunt echipate cu o punte redresoare introdusă în cutia de borne a motorului. Toate redresoarele sunt echipate cu protecție la supratensiune în limitele toleranțelor permise. Sunt disponibile diverse versiuni de redresoare, inclusiv modele cu pornire de varf și tipuri rapide pentru o aplicare mai rapidă a franei.

Rectifiers

Brake motors with direct current brake (series S, K, H and R) are equipped with a bridge rectifier inserted inside the motor's terminal box. All rectifiers are equipped with surge protection within the allowed tolerances. Different versions of rectifiers are available, including models with peak start and rapid types for increased brake reaction speed.

Tip Tipo	V _~ Input	V _~ Output	A (max)	Cablu INTRARE Wires INPUT	Cablu IESIRE (+/-) Wires OUTPUT (+/-)	Forma unda de iesire Output waveform
AS4	0-500	0-225	2	Gri/Gri Grey/Grey	Rosu/Negru Red/Black	
AP2	150-280	67-126	1	Maro/Maro Brown/Brown	Rosu/Negru Red/Black	
AP4	250-480	112-215	1	Mov/Mov Violet/Violet	Rosu/Negru Red/Black	
AS2R	190-280	85-126	1	Albastru/Albastru Blue/Blue	Rosu/Negru Red/Black	
AS4R	250-480	112-215	1	Galben/Galben Yellow/Yellow	Rosu/Negru Red/Black	
AP2R	150-280	67-126	1	Maro/Maro Brown/Brown	Rosu/Negru Red/Black	
AP4R	250-480	112-215	1	Mov/Mov Violet/Violet	Rosu/Negru Red/Black	

(tab. 22)

Model AS

Redresor simplu cu unda întreaga, protejat de varistoare la intrare și iesire. Potrivit pentru alimentarea franelor electromagnetice unde nu sunt necesare un cuplu de franare ridicat, un răspuns rapid și o dezactivare.

Model AP

Redresor cu tehnologie avansată, potrivit pentru aplicații care necesită o viteză mare de deschidere sau un cuplu de franare crescut. Circuitul furnizează un curent cu undă întreaga la pornire, care scade la o undă întreaga după aproximativ o secundă. Acest lucru permite amplificarea franei la pornire, obținându-se astfel efectele descrise mai sus.

Nota: Este important să utilizați redresorul la intrarea în tensiune și nu la cablurile de ieșire. Funcționarea perfectă a redresorului nu este garantată pentru cicluri de funcționare mai scurte de 1,5 secunde.

Nota: Înainte de utilizare, asigurați-vă că sursa de alimentare este sinusoidală (nu patrata) și nu depășește temperatura nominală. De asemenea, asigurați-vă că nu există interferențe de radiofrecvență, electromagnetice sau alte interferențe electrice.

Model R

Potrivit în special pentru aplicații care necesită un timp de oprire rapid, fără a fi nevoie de un contact pe circuitul de curent continuu. Datorită unui comutator static, circuitul de curent continuu este deschis atunci când alimentarea cu curent alternativ se întrerupe, eliminând astfel necesitatea unui contact extern.

AS model

Simple half wave rectifier protected by varistors in input and output. Suitable to power electromagnetic brakes where there are no particular requirements for brake torque, intervention speed and de-energisation.

AP model

Advanced technology rectifier for circumstances where high speed opening or greater brake torque is required. The circuit supplies the starter with a full wave current, which after about one second becomes a half wave. This means that during the "start" moment, the brake is supplied with a power surge, thus obtaining the above-described effects.

Note: When using the rectifier, it is important to act on the inbound voltage and not on the outbound cables. For work cycles less than 1.5s, perfect rectifier operation cannot be guaranteed.

Note: Before use, make sure the wave type is sinusoidal and not square and do not exceed the temperature indicated on the ID plate. Also make sure there are no electromagnetic radio frequency disturbances and electrical disturbances in general.

R model

Particularly suited in cases where a rapid stop time is necessary, without the need to use a contact on the direct current circuit. Thanks to a static switch, the DC circuit opens the instant the alternate power is cut off, thus eliminating the need for an external contact.

◆ 5.3 Motoare cu frana de curent continuu, cu economie de spatiu, seria S S Series compact direct current brake motors

Frana cu arc din seria S este o frana de curent continuu. Scopul franei este de a opri miscarea de rotatie a unui arbore mecanic.

The S series spring activated brake is a direct current brake. The aim of the brake is to stop the rotary movement of a mechanical shaft.

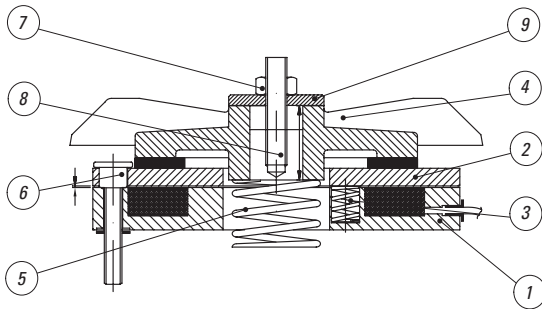

fig.1

- 1 Electromagnet
- 2 Ancora
- 3 Arcuri de torsiune
- 4 Ventilator
- 5 Arc de compresie
- 6 Suruburi de fixare
- 7 Piulita
- 8 Surub cap etans
- 9 Saiba

- 1 Electromagnet
- 2 Armature Plate
- 3 Torque springs
- 4 Fan
- 5 Compensating spring
- 6 Fixing screws
- 7 Nut
- 8 Stud
- 9 Washer



Principalele caracteristici ale franei:

- ◆ Structura extrem de robusta;
- ◆ Extrem de silentioasa in timpul functionarii (<70 dBA in conformitate cu Directiva 2006/42/CE);
- ◆ Cuplu de franare ridicat. In special, seria S atinge cupluri de franare ridicate pentru o frana de curent continuu de aceasta dimensiune;
- ◆ Disipare excelenta a caldurii. Ventilatorul actioneaza si ca disc de franare, disipand caldura generata in timpul franarii, reducand la minimum uzura materialului de frictiune;
- ◆ Bobina electromagnetului este complet calita cu rasina epoxidica, iar piesele mecanice sunt protejate prin placare cu zinc tropicalizat;
- ◆ Gama larga de aplicatii. Frana poate fi utilizata in orice aplicatie cu un motor standardizat, fara a utiliza echipamente sau piese speciale. In plus, frana poate functiona in orice pozitie.

Main brake specifications:

- ◆ Very sturdy structure;
- ◆ Extremely silent inverters and operation (<70dBA as per directive 2006/42/EC);
- ◆ High brake torque. In particular, the S series allows high brake torques for direct current brakes of these dimensions;
- ◆ Excellent heat dissipation. The fan also acts as a disc brake with the advantage of dissipating the heat that forms during brake, thus limiting the wear of the friction material;
- ◆ The electromagnetic coil is completely cemented with epoxy resin and the mechanical parts are protected by tropicalised galvanising;
- ◆ Broad possibilities for use. The brake can in fact be used in any application with a normalised motor, without the need for any particular equipment or special parts. Moreover, the brake can work in any position.

5. Motoare cu autofranare

Operatiune

Frana este proiectata sa asigure, in repaus si prin intermediul arcurilor de torsiune, o siguranta intrinseca egala cu si care nu depaseste valoarea sa de identificare exprimata in Nm. Cand electromagnetul (1) este alimentat, armatura (2) este atrasa spre el, solicitand arcurile de torsiune (3). Acest lucru permite ventilatorului (4), cuplat la arborele mecanic printr-o cheie, sa se roteasca liber. In absenta curentului, campul magnetic inceteaza si, in consecinta, arcurile de torsiune imping armatura impotriva ventilatorului, franand astfel arborele mecanic.

Operation

The brake has been designed to guarantee intrinsic safety equal to and not higher than the value expressed in Nm on the ID plate, during rest and through the torque springs. When the electromagnet (1) is energised, the armature plate (2) is attracted to it, thus loading the torque springs (3). This allows the fan (4), coupled to the mechanical shaft by way of a key, to turn freely. In the absence of power, the magnetic field is eliminated and the torque springs consequently push the armature plate towards the fan, thus brake the mechanical shaft.

Date tehnice frana S / S brake technical specifications

Tip frana / Brake Model		S 63	S 71	S 80	S 90	S 100	S 112	S 132	S 160/180
cuplu de franare static / static brake torque	(Nm)	2,5	4	9	10	12	13	17	50
turatie maxima de rotatie a motorului / max motor rotation speed	(rpm)	3600	3600	3600	3600	3600	3600	3600	3600
putere / output	(W)	23	23	45	45	60	60	60	70
moment de inertie maxim admis / max allowable moment of inertia	(Kg m ²)	0,0458	0,0534	0,0552	0,0628	0,1061	0,1283	0,1544	0,460
inertia ventilatorului / fan inertia	(Kg m ²)	3,7	4,7	11,1	11,1	27	27	66	147
moment de inertie al motorului / moment of inertia of motor	(Kg m ²)	0,00096	0,0021	0,0068	0,0093	0,015	0,024	0,059	0,17
nivel maxim de zgomot / max sound level	(dB-A)	68	68	69	69	66	66	66	67

Nota: Inainte de rodajul franei, valoarea cuplului de franare static poate abate cu aproximativ ±20% de la valoarea raportata.

Notes: Before the brake is run-in, the value of the static brake torque may deviate by about ± 20% from the indicated value.

(tab. 23)

05

Schema de conectare a franei si tensiunile permise Brake connection diagram and allowed voltage

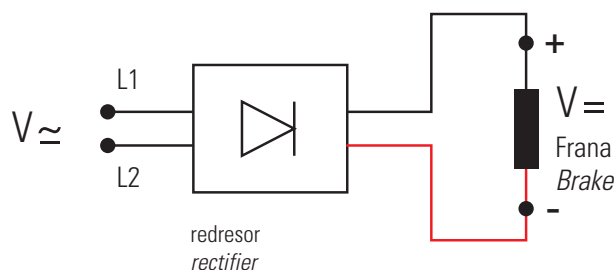

S			
Hz	V ≈ intrare / input L1 - L2	redresor / rectifier	V = frana / brake
50	220 - 230 - 240	AS4 - AS4R - AP2 - AP2R	100
	255		
60	220 - 230 - 240	AP2 - AP2R	180
	380 - 400 - 415	AS4 - AS4R - AP2 - AP2R	
60	440	AP4 - AP4R	180
	380 - 400 - 415		

Alte tensiuni disponibile la cerere / Other voltages supplied on request

(tab. 24)

Timpii de interventie / Intervention times

S			
Frana Brake	Timpul de dezactivare a electromagnetului Electromagnet de-energising time [ms]	Timpul de activare a electromagnetului Electromagnet energising time [ms]	Timp rapid de energizare a electromagnetului Electromagnet rapid energising time [ms]
63	20	40	25
71	15	100	30
80	15	120	45
90	15	120	45
100	10	200	55
112	10	200	55
132	10	200	55
160/180	13	215	65

Note. Daca redresoarele rapide sunt utilizate (P-PR) pentru mai mult de 15 interventii pe minut in regim continuu, este necesara o deconectare de la tensiune de 2 secunde intre fiecare interventie.

Notes. If the rapid rectifiers are used (P-PR) for more than 15 interventions per minute in continuous duty, 2-second de-energising is needed between each intervention.

(tab. 25)

Important!

Functionarea corecta a franelor poate fi garantata atunci cand functioneaza la temperatura ambianta. Daca frana este utilizata in medii uleioase sau cu temperaturi ridicate, va rugam sa contactati personalul nostru tehnic.

Important!

Correct brake operation can be guaranteed when operating at environmental temperature. If the brake is used in oily or high-temperature environments, we kindly request that you contact our technical staff.

Intretinere si reparatii

Frana si toate componentele acesteia trebuie inspectate frecvent, deoarece frecarea depinde de o multitudine de factori, cei mai importanti fiind inertia sarcinii, viteza motorului si frecventa de utilizare.

Placa de armatura trebuie inlocuita odata ce materialul de frictiune a fost consumat cu 1,5 mm. Cand intrefierul atinge o valoare egala cu 0,7 mm, valoarea respectiva trebuie adusa la 0,2 mm.

Asigurati-va ca, dupa inspectie, intrefierul a fost reglat corect. Inspectiile trebuie efectuate cu frana deconectata electric si dupa verificarea conexiunii la masa. Performanta franei poate fi garantata numai daca este utilizata cu piese originale furnizate de producator. Pentru informatii mai detaliate, va rugam sa ne informati cu privire la conditiile specifice de functionare ale franei.

Maintenance and repairs

The brake and all of its parts must be frequently inspected as friction depends on a multitude of factors, most importantly load inertia, motor speed and frequency of use.

The armature plate must be replaced once the friction material has been consumed by 1.5 mm. When the air-gap reaches a value equal to 0.7 mm, said value must be brought to 0.2 mm.

Make sure that after the inspection, the air-gap has been properly adjusted. Inspections must be carried out with the brake electrically disconnected and after checking for a ground connection. Brake performance can only be guaranteed if used with original parts supplied by the manufacturer. For more detailed information, we kindly ask you to inform us of the specific operating conditions of the brake.

Reglarea spatiului liber

Folosind piulita (fig.1) reglatai spatiul liber dintre placa de armatura si electromagnet. Daca este reglat dupa o tura de lucru, asigurati-va ca corpul franei nu este supraincalzit. Valoarea maxima admisa a spatiului liber este de 0,7 mm. Daca aceasta valoare este depasita din cauza consumului de material de frictiune, performanta franei poate fi afectata. Mai mult, daca valoarea maxima a spatiului liber este depasita, acest lucru va duce la deschiderea sistemului in timpul rotatiei, provocand ulterior supraincalzirea motorului si a franei. Depasirea valorii spatiului liber poate duce la o scadere a performantei franei si, in cele din urma, la defectarea acesteia.

Air-gap regulation

Using the nut (fig.1), adjust the air-gap between the armature plate and the electromagnet. If adjusted after a work shift, make sure the body of the brake is not overheated. The maximum allowed value of the air-gap is 0.7 mm. If this value is exceeded due to the consumption of friction material, brake performance may be affected. Moreover, if the maximum air-gap value is exceeded, this will cause the system to open during rotation, subsequently causing the motor and brake to overheat. Exceeding the air-gap value may lead to a decline in brake performance and eventually brake failure.

Curbe limita maxima de functionare seria S / S series maximum operating limit curves

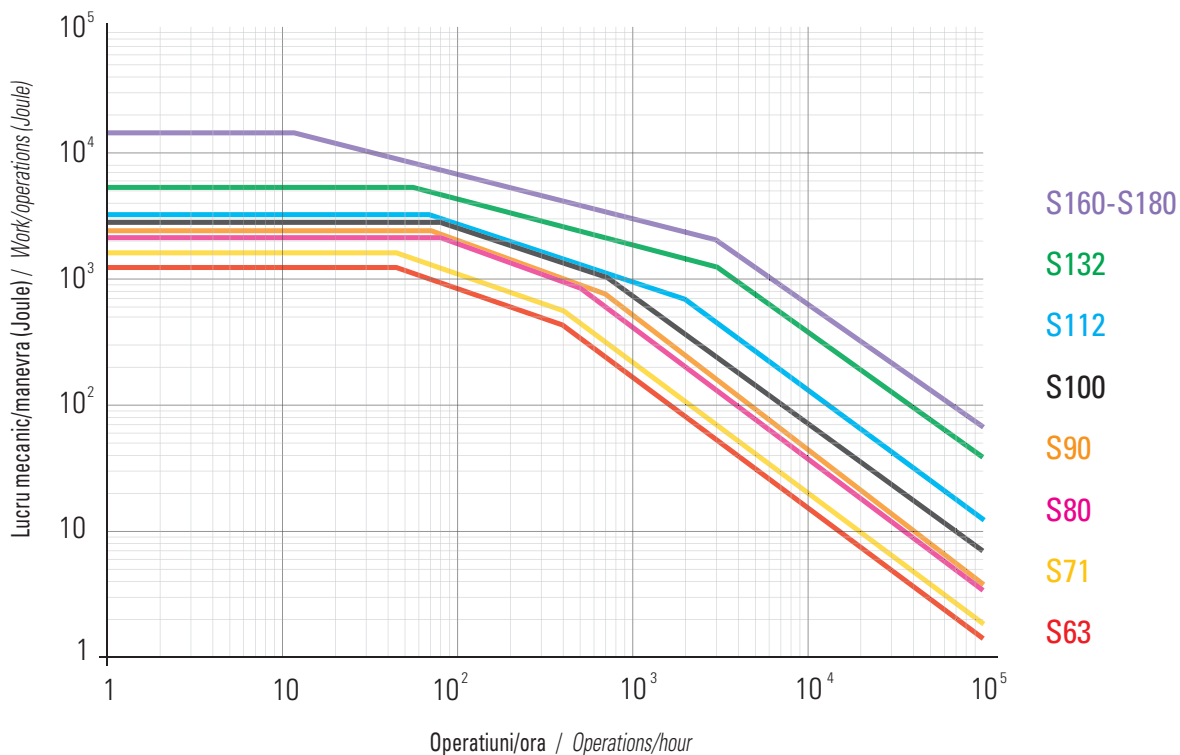

Nota: valorile de disipatie indicate in grafic sunt valabile numai pentru vitezele de rotatie raportate in tabel
 Note: the dissipation values indicated in the graph are valid only for the rotation speeds reported in the table

◆ 5.4 Motoare cu frana de curent continuu seria K-H *K-H series direct current brake motors*

Frana electromagnetica actionata cu arc din seria K-H este o frana de curent continuu. Scopul franei este de a opri miscarea de rotatie a unui arbore mecanic.

The K-H series spring activated electromagnetic brake is a direct current brake. The aim of the brake is to stop the rotary movement of a mechanical shaft.

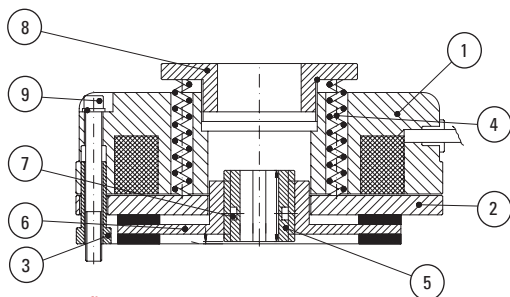

fig.2

- | | |
|-------------------------------|---------------------------|
| 1 Electromagnet | 1 Electromagnet |
| 2 Placa de armatura | 2 Armature plate |
| 3 Surub de reglare | 3 Adjustment screw |
| 4 Arcuri de torsiune | 4 Torque springs |
| 5 Butuc canelat | 5 Splined hub |
| 6 Disc | 6 Disc |
| 7 Inel O | 7 O-ring |
| 8 Surub de reglare a cuplului | 8 Torque regulation screw |
| 9 Suruburi de fixare | 9 Fixing screws |



Caracteristicile generale sunt:

- ◆ Structura foarte robusta;
- ◆ Functionare foarte silentioasa (<70 dBA in conformitate cu Regulamentul 2006/42/CE);
- ◆ Instalare simpla si intretinere usoara;
- ◆ Disipare buna a caldurii datorita ventilatorului motorului sau capacului. Capacul motorului, deoarece actioneaza si ca suprafata de frana, trebuie sa fie fabricat din otel sau fonta.
- ◆ Bobina este complet incapsulata intr-o rasina epoxidica, iar partile mecanice sunt protejate prin zincare tropicalizata;
- ◆ Eliberarea manuala este la cerere.

General characteristics are:

- ◆ *Very strong structure;*
- ◆ *Very quiet in operating (<70 dBA in accordance with Regulation 2006/42/EC);*
- ◆ *Simple to install and easy to maintain;*
- ◆ *Good heat dissipation due to the motor fan or cover. The motor cover, as it acts also as brake surface, must be made of steel or cast iron.*
- ◆ *The coil is fully encased in an epoxy resin and the mechanical parts are protected by tropicalized zincplating;*
- ◆ *Hand release is on request.*

Functionare

Frana a fost proiectata pentru a garanta in repaus si prin intermediul arcurilor de torsiune, o siguranta intrinseca egala cu si nu mai mare decat valoarea exprimata in Nm pe placuta de identificare. Cand electromagnetul (1) este energizat, placa de armatura (2) este atrasa de acesta, incarcand astfel arcurile de torsiune (3). Acest lucru permite discului (4), cuplat la arborele mecanic prin intermediul unui butuc canelat (5), sa se roteasca liber. In absenta alimentarii cu energie electrica, campul magnetic este eliminat, iar arcurile de torsiune imping, in consecinta, placa de armatura spre disc, franand astfel arborele mecanic.

Operation

The brake has been designed to guarantee during rest and through the torque springs, intrinsic safety equal to and not higher than the value expressed in Nm on the ID plate. When the electromagnet (1) is energised, the armature plate (2) is attracted to it, thus loading the torque springs (3). This allows the disc (4), coupled to the mechanical shaft by way of a splined hub (5), to turn freely. In the absence of power, the magnetic field is eliminated and the torque springs consequently push the armature plate towards the disc, thus brake the mechanical shaft.

Date tehnice frane K / K brake technical specifications

		K												
Tip / Type		K63	K71	K80	K90	K100	K112	K132	K160/180	K200	K200	K225	K250	K280
Cuplu de franare static Static brake torque	(Nm)	5	12	16	20	40	60	90	200	400	300	600	800	1000
Turatia maxima a motorului Maximum motor speed	(rpm)	3600	3600	3600	3600	3600	3600	3600	1800	1800	1800	1800	1800	1800
Putere Output	(W)	20	25	30	35	45	55	65	70	70	90	90	150	150
Niveluri sonore Sound levels	(dB-A)	68	69	68	69	70	70	70	70	70	70	70	70	70

(tab. 26)

Schema de conectare a franei si tensiunea admisa Brake connection diagram and allowed voltage

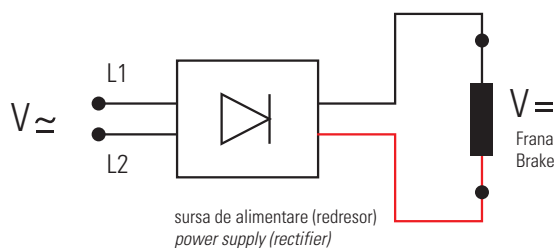

K - H			
Hz	V ≈ intrare / input L1 - L2	redresor / rectifier	V = frana / brake
50	220 - 230 - 240	AP2 - AP2R	100
60	255		
	220 - 230 - 240		
50	380 - 400 - 415	AP4 - AP4R	180
60	440		
	380 - 400 - 415		

Alte tensiuni furnizate la cerere / Other voltages supplied on request

(tab. 27)

Reglarea cuplului de franare

Frana K permite un cuplu de franare variabil. In functie de sarcina, viteza de rotatie si timpul de franare, utilizatorul poate seta cuplul de franare cel mai potrivit nevoilor sale de lucru.

Daca volumul de munca permite, reglarea cuplului de franare sub 100% va reduce uzura materialului de frecare al franei.

Brake torque regulation

Brake K allows the brake torque to be changed. Depending on the load, the rotation speed and brake time, the user can set the brake torque most suited to their operating needs. If the work load allows, regulating the brake torque to less than 100% will reduce the wear of the brake's friction material.

K														
Cuplu de franare bazat pe valoarea „A” (distanța dintre suprafața superioară a piulitei inelare și suprafața magnetului)														
Brake torque based on value “A” (distance between upper surface of ring nut and magnet surface)														
Tip / Type		K63	K71	K80	K90	K100	K112	K132	K160/180	K200	K200	K225	K250	K280
100% max	A (mm)	5,2	4,6	5,9	8,2	8,2	8,2	8,2	8,2	8,2	8,2	8,2	18,6	18,6
	Cf (Nm)	5,0	12,0	16,0	20,0	40,0	60,0	90,0	200,0	400,0	300,0	600,0	800,0	1500,0
75%	A (mm)	6,9	6,1	6,2	7,1	10,7	10,3	9,9	9,7	9,7	10,7	10,7	20,6	20,6
	Cf (Nm)	3,8	9,0	12,0	15,0	30,0	45,0	67,5	150,0	300,0	225,0	450,0	762,0	1430,0
50%	A (mm)	8,7	7,6	7,6	8,5	13,2	12,5	11,7	11,2	11,2	13,2	13,2	22,6	22,6
	Cf (Nm)	2,5	6,0	8,0	10,0	20,0	30,0	45,0	100,0	200,0	150,0	300,0	725,0	1361,0

Note. Inainte de rodajul franei, valoarea cuplului de franare static poate abate cu aproximativ ± 20% de la valoarea indicata.

Notes. Before the brake is run-in, the value of the static brake torque may deviate by about ± 20% from the indicated value.

(tab. 28)

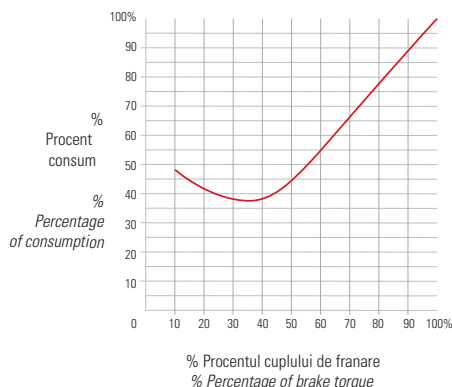
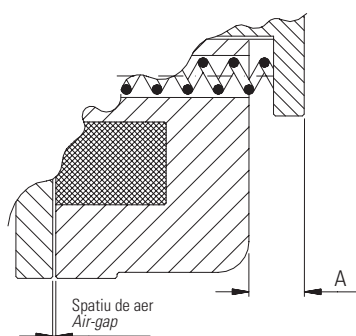

Timpii de interventie / Intervention times

K			
Frana Brake	Timpul de dezactivare a electromagnetului Electromagnet de-energising time	Timpul de activare a electromagnetului Electromagnet energising time	Timp rapid de energizare a electromagnetului Electromagnet rapid energising time
	[ms]	[ms]	[ms]
63	10	45	20
71	15	50	30
80	15	55	30
90	15	65	40
100	20	75	45
132	25	180	85
160-180	50	200	95
200	60	210	100
225-280	30	310	135

Note. Daca redresoarele rapide sunt utilizate (P-PR) pentru mai mult de 15 interventii pe minut in regim continuu, este necesara o deconectare de la tensiune de 2 secunde intre fiecare interventie.

Notes. If the rapid rectifiers are used (P-PR) for for more than 15 interventions per minute in continuous duty, 2-second de-energising is needed between each intervention.

(tab. 29)

Important!

Functionarea corecta a franelor poate fi garantata atunci cand functioneaza la temperatura ambianta. Daca frana este utilizata in medii uleioase sau cu temperaturi ridicate, va rugam sa contactati personalul nostru tehnic.

Important!

Correct brake operation can be guaranteed when operating at environmental temperature. If the brake is used in oily or high-temperature environments, we kindly request that you contact our technical staff.

Intretinere si reparatii

Frana si toate componentele acesteia trebuie inspectate frecvent, deoarece frecarea depinde de o multitudine de factori, cei mai importanti fiind inertia sarcinii, viteza motorului si frecventa de utilizare. Discul trebuie inlocuit odata ce materialul de frictiune a fost consumat cu 3 mm. Asigurati-va ca, dupa inspectie, intrefierul a fost reglat corect. Inspectiile trebuie efectuate cu frana deconectata electric si dupa verificarea conexiunii la masa. Performanta franei poate fi garantata numai daca este utilizata cu piese originale furnizate de compania noastra. Pentru informatii mai detaliate, va rugam sa ne informati cu privire la conditiile specifice de functionare ale franei (fig.2).

Maintenance and repairs

The brake and all of its parts must be frequently inspected as friction depends on a multitude of factors, most importantly load inertia, motor speed and frequency of use. The disc must be replaced once the friction material has been consumed by 3 mm. Make sure that after the inspection, the air-gap has been properly adjusted. Inspections must be carried out with the brake electrically disconnected and after checking for a ground connection. Brake performance can only be guaranteed if used with original parts supplied by our company. For more detailed information, we kindly ask you to inform us of the specific operating conditions of the brake (fig.2).

Reglarea fasiei de aer

Fasia de aer se regleaza folosind suruburile de reglare (8), dupa slabirea suruburilor de fixare (9). Daca aceasta operatiune se efectueaza dupa o tura de lucru, asigurati-va ca corpul franei nu este supraincalzit. Valoarea nominala de reglare a fasiei de aer este de 0,2 mm (+0,05-0). Valoarea maxima admisa pentru fasia de aer este de 0,7 mm. Daca aceasta valoare este depasita din cauza consumului de material de frictiune, performanta franei poate fi afectata; in plus, depasirea valorii maxime a fasiei de aer poate duce la o scadere a performantei franei si, in cele din urma, la nefunctionarea sistemului in timpul rotatiei, cu supraincalzirea ulterioara a motorului si a franei si, inevitabil, la intreruperea functionarii.

Air-gap regulation

The air-gap is regulated using the adjustment screws (8), after having loosened the fixing screws (9). If this operation is performed after a work shift, make sure the body of the brake is not overheated. The nominal air-gap regulation value is 0.2 mm (+0.05-0). The maximum allowed value for the air-gap is 0.7 mm. If this value is exceeded due to the consumption of friction material, brake performance may be affected; moreover, exceeding the maximum air-gap value may lead to a decline in brake performance, and eventually the failure of the system to open during rotation, with subsequent overheating of the motor and brake and inevitably the interruption of operations.

Curbe limita maxima de lucru Seria K/ Maximum work limit curves K Series

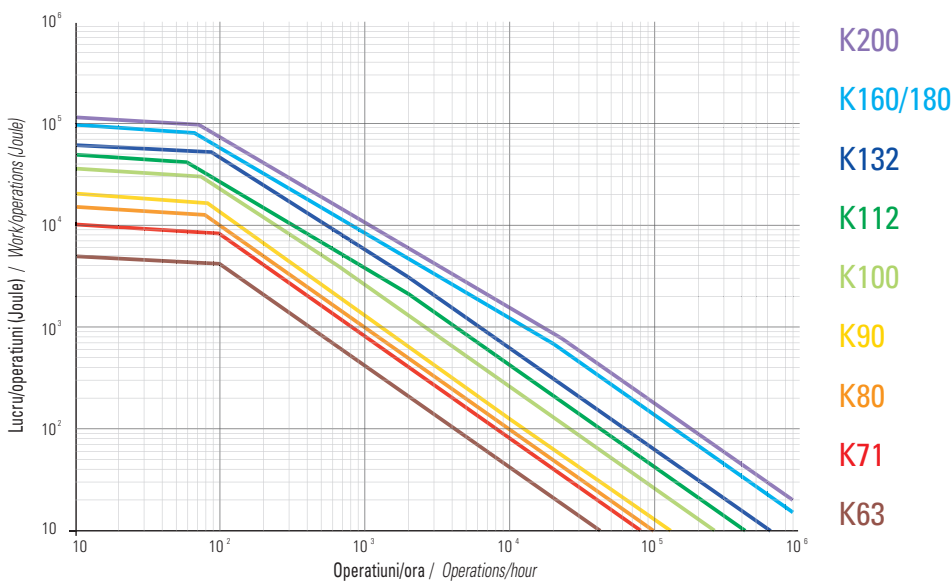

Nota: valorile de disipatie indicate in grafic sunt valabile numai pentru vitezele de rotatie raportate in tabel.
 Note: the dissipation values indicated in the graph are valid only for the rotation speeds reported in the table.

◆ 5.5 Motoare cu frana de curent continuu pentru teatre H DC brake motors for theatres H

Pentru acest tip de aplicatie a fost dezvoltata o solutie tehnica speciala, care permite reducerea la minimum a zgomotului in timpul fazei de deschidere si inchidere. Configuratia tipica, asa cum se arata in imagine, include o flansa de conectare intre cele doua frane.

Din acest motiv, doar una dintre ele poate avea un cuplu reglabil, in timp ce cealalta va avea o valoare a cuplului egala cu valoarea maxima prevazuta pentru dimensiunea corespunzatoare. Valorile cuplului de franare pot fi crescute datorita frecventei de lucru foarte scazute. Sistemul este furnizat cu doua aparatori anti-praf si doua parghii de eliberare separate. Consultati detaliile seriei K din catalogul general pentru specificatiile generale ale franei si pentru diagramele de functionare si deteriorare.

A particular technical solution has been developed for this type of application, which allows noise to be reduced to a minimum during the opening and closing phase. The typical configuration, as shown in the picture, includes a connecting flange between the two brakes.

For this reason, only one of them may have an adjustable torque, whilst the other will have a torque value equal to the maximum value envisaged for the corresponding size. Brake torque values can be increased due to the very low working frequency. The system is supplied with two dustproof guards and two separate releasing levers. See K series details in the general catalogue for the overall specifications of the brake and for the operating and deterioration charts.

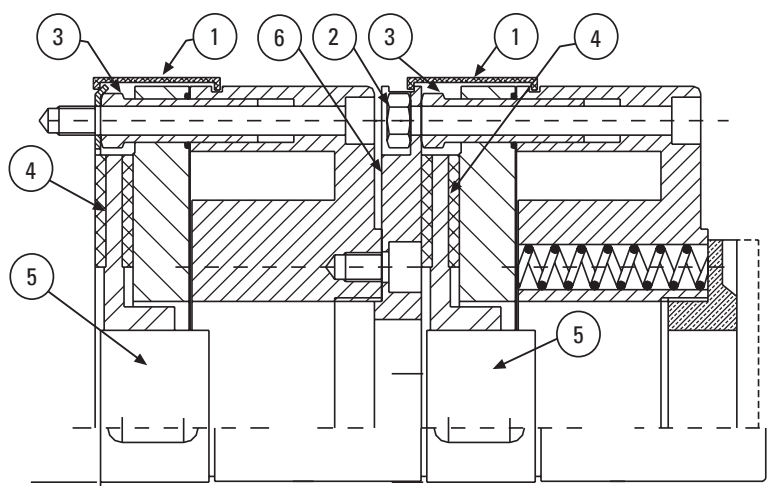

- | | | | |
|---|----------------------------|---|-------------------------|
| 1 | Protectie din cauciuc | 1 | Rubber protection |
| 2 | Piulita | 2 | Nut |
| 3 | Piulita de reglare | 3 | Adjuster nut |
| 4 | Disc | 4 | Disc |
| 5 | Butuc canelat | 5 | Splined hub |
| 6 | Flansa speciala de montare | 6 | Special mounting flange |

Specificatii tehnice / Technical specifications

Tipo / Type	H 90	H 100	H 112	H 132	H 160	H 180
cuplul static de franare pentru o frana / static brake torque for one brake (Nm)	16	35	60	80	150	250
turatia maxima de rotatie a motorului / max motor rotation speed (rpm)	3000	3000	3000	3000	3000	3000
puterea electrica a unei frane / electric power of one brake (W)	30	45	50	55	60	65
nivelul maxim de zgomot / max. sound level (dB-A)	50	50	50	50	50	50

(tab. 30)

◆ 5.6 Motor electric cu frana de curent continuu, frana pozitiva, seria R DC brake motor, positive brake, R series

Franele din seria R sunt frane de parcare, a caror actiune de franare are loc atunci cand bobina electromagnetica este alimentata cu energie.

Cu toate acestea, franarea dinamica a arborelui motorului este garantata sub o valoare limita de rotatie admisibila pentru tipul de frana (vezi paragraful „Selectia franei”).

Series R brakes are parking brakes, whose brake action occurs when power is present in the electromagnetic coil.

However, the dynamic brake of the motor shaft is guaranteed below a limit value of admissible rotation for the type of brake (see paragraph “Brake selection”).

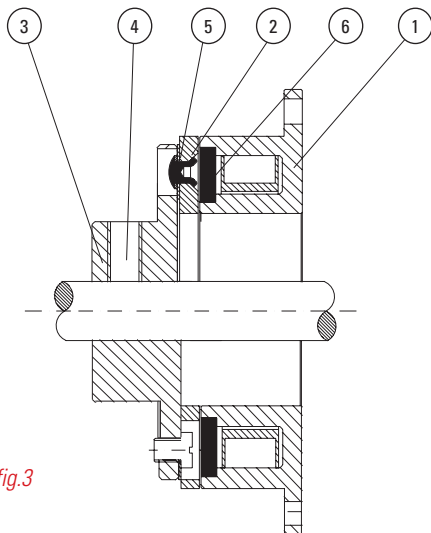

fig.3

1 Electromagnet	1 Electromagnet
2 Placa de armatura	2 Armature plate
3 Butuc canelat	3 Splined hub
4 Stift	4 Stud
5 Arc de torsiune	5 Torque spring
6 Inel de frecare	6 Friction ring

Principalele caracteristici ale franei din seria R sunt:

- ◆ Nivel redus de zgomot in timpul functionarii (< 70dB conform Directivei 2006/42/CE);
- ◆ Cost redus datorita simplitatii asamblarii;
- ◆ Disipare buna a caldurii. Calitatea buna a materialelor si caracteristicile constructive permit atingerea unei valori ridicate de disipare;
- ◆ Bobina electromagnetica este incapsulata in intregime in rasina epoxidica, cu exceptia cazului in care se specifica altfel in criteriile de constructie;
- ◆ Partile mecanice sunt galvanizate;
- ◆ Posibilitati largi de utilizare. Frana poate fi, de fapt, aplicata oricarui tip de motor standardizat fara a utiliza echipamente si piese speciale. Mai mult, tehnica particulara de constructie permite functionarea in orice pozitie, inclusiv verticala.

Functionare

Frana are doua parti: electromagnetul, inclusiv inelul de frictiune, si butucul, care este conectat la arborele motorului care urmeaza sa fie franat. Electromagnetul (1) este conectat la motor prin intermediul suruburilor. Butucul (3) este fixat pe arborele motorului cu ajutorul penei si mentinut in pozitie de stiftul (4) sau cu un ansamblu de blocare (la cerere). Placa de armatura (2) este conectata la butuc prin intermediul arcului (5). La excitarea magnetului, placa de armatura este antrenata spre acesta si frana porneste. Prin eliminarea curentului, placa de armatura este readusa in pozitia sa de catre arcul chevron, eliberand astfel butucul si permitand arborelui motorului sa se roteasca.

The main characteristics of the R Series brake are:

- ◆ Low level noise when working (< 70dB as per Directive 2006/42/EC);
- ◆ Low cost thanks to the simplicity of assembly;
- ◆ Good heat dissipation. The good quality of the materials and the construction characteristics mean a high dissipation value can be reached;
- ◆ The electromagnetic coil is entirely encased in epoxy resin, unless otherwise stated in the construction criteria;
- ◆ The mechanical parts are galvanised;
- ◆ Broad possibilities for use. The brake can, in fact, be applied to any type of standardised motor without the use of special equipment and special parts. Moreover, the particular construction technique means it can work in any position, including vertical.

Operation

The brake has two parts: the electromagnet, including the friction material ring, and the hub, which is connected to the motor shaft to be braked. The electromagnet (1) is connected to the motor by means of the screws. The hub (3) is fixed to the motor shaft by means of the key and kept in position by the stud (4), or with a locking assembly (on request). The armature plate (2) is connected to the hub by means of the spring (5). On exciting the magnet, the armature plate is driven towards it and the brake starts. By removing the current, the armature plate is returned to its position by the chevron spring, thus releasing the hub and allowing the motor shaft to turn.

Specificatii tehnice ale franei R / R brake technical specifications

Tip / Type	R 71	R 80/90	R 100/112	R 132	R 160	R 180
cuplu static de franare pentru o frana / static brake torque for one brake (Nm)	5	14	30	60	120	220
viteza maxima de rotatie a motorului / max speed of motor rotation (rpm)	8000	6000	5000	4000	4000	4000
viteza maxima de functionare / maximum operating speed (rpm)	1000	1000	750	750	500	500
inertie flansa/ flange inertia (Kg. mm ²)	47,67	202	587	1400	5320	11000
putere maxima / maximum power (W)	11	16	21	28	38	40

Note. Inainte de rodarea franei, valoarea cuplului de franare static se poate modifica cu ±20% fata de valoarea indicata. Valorile afisate in tabel pot fi modificate de producator fara notificare prealabila.

Notes. Before the brake is run in, the static brake torque value could change by ±20% from the value indicated. The values shown in the table may be changed by the manufacture without notice.

(tab. 31)

Schema de conectare a franei si tensiunea admisa Brake connection diagram and allowed voltage

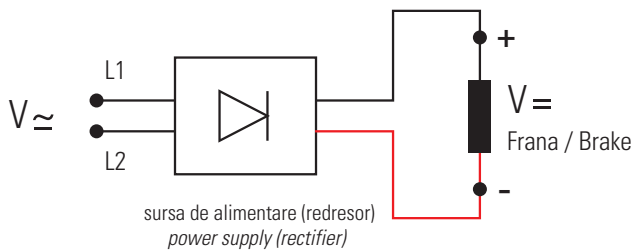

R			
Hz	V ≈ intrare / input L1 - L2	redresor / rectifier	V = frana / brake
50	220 - 230 - 240	AP2 - AP2R	100
60	255		
	220 - 230 - 240		
50	380 - 400 - 415	AP4 - AP4R	180
60	440		
	380 - 400 - 415		

Alte tensiuni furnizate la cerere / Other voltages supplied on request

(tab. 32)

Timpii de interventie / Intervention times

R		
Frana Brake	Timp de dezactivare a electromagnetului Electromagnet de-energising time [ms]	Timp de activare a electromagnetului Electromagnet energising time [ms]
71	34	11
80/90	40	20
100/112	58	31
132	58	31
160	92	50
180	106	63

Note. Daca redresoarele rapide sunt utilizate (P-PR) pentru mai mult de 15 interventii pe minut in regim continuu, este necesara o dezactivare de 2 secunde intre fiecare interventie.

Notes. If the rapid rectifiers are used (P-PR) for more than 15 interventions per minute in continuous duty, 2-second de-energising is needed between each intervention.

(tab. 33)

Limitari importante!

Functionarea corecta a franei poate fi garantata atunci cand functioneaza la temperatura ambianta. Daca frana trebuie sa functioneze in medii uleioase sau in medii cu temperaturi extreme, va rugam sa contactati biroul nostru tehnic.

Important limitations!

Correct operation of the brake can be guaranteed when operating at ambient temperature. If the brake needs to work in oily environments or in environments with extreme temperatures, please contact our technical office.

Curbe limita maxima de lucru Seria R / Maximum work limit curves R Series

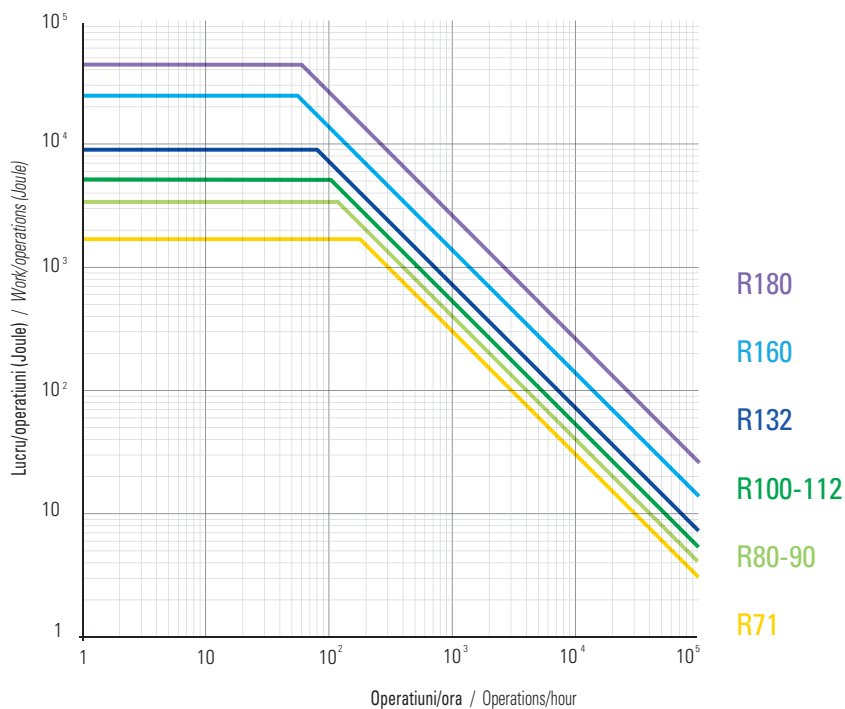

*Nota: valorile de disipatie indicate in grafic sunt valabile numai pentru vitezele de rotatie raportate in tabel.
Note: the dissipation values indicated in the graph are valid only for the rotation speeds reported in the table.*

◆ 5.7 Caracteristicile motoarelor cu frana de curent alternativ, seria C *Characteristics of AC brake motors, C Series*

Frana electromecanică cu arc din seria C este o frana de curent alternativ. Scopul franei este de a opri mișcarea de rotație a unui arbore mecanic.

The electromechanical spring-loaded C Series brake is an AC brake. The aim of the brake is to stop the rotary movement of a mechanical shaft.

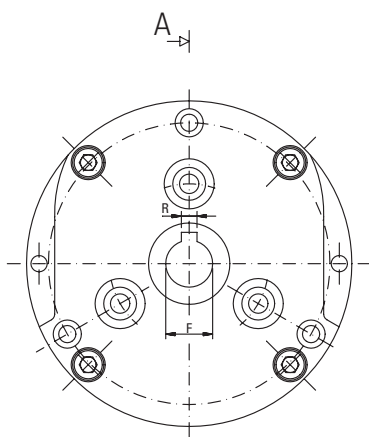
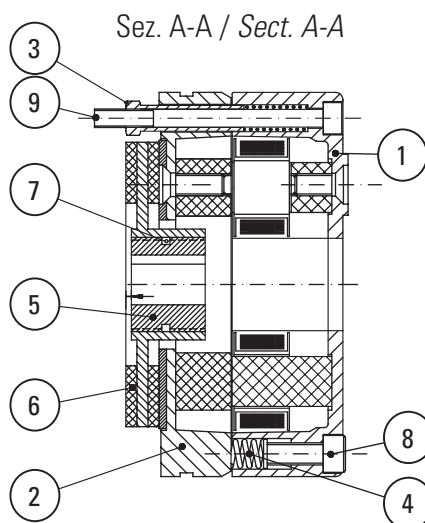

fig.4



- | | |
|-------------------------------|---------------------------|
| 1 Electromagnet | 1 Electromagnet |
| 2 Placa de armatura | 2 Armature plate |
| 3 Surub de reglare | 3 Adjuster screw |
| 4 Arcuri de torsiune | 4 Torque springs |
| 5 Butuc canelat | 5 Splined hub |
| 6 Disc | 6 Disc |
| 7 Inel O | 7 O-ring |
| 8 Surub de reglare a cuplului | 8 Torque regulation screw |
| 9 Suruburi de fixare | 9 Fixing screws |



Principalele caracteristici ale franei din seria C sunt:

- ◆ Structura foarte robusta;
- ◆ Foarte simplu de asamblat;
- ◆ Nivel redus de zgomot la functionare (< 70 conform Directivei 2006/42/CE);
- ◆ Buna disipare a caldurii prin structura formata din aluminiu turnat sub presiune si prin ventilatorul motorului electric;
- ◆ Bobina electromagnetica este invelita in intregime in rasina epoxidica;
- ◆ Frana este furnizata cu eliberare manuala, la cerere.

Functionare

Frana (fig.4) este proiectata sa asigure, in repaus si prin intermediul arcurilor de torsiune, o siguranta intrinseca egala cu si care nu depaseste valoarea sa nominala exprimata in Nm. Cand electromagnetul (1) este alimentat, armatura (2) este atrasa spre acesta, incarcand arcurile de torsiune (4). Acest lucru permite discului (6), cuplat la arborele mecanic printr-un butuc dintat (5), sa se roteasca liber. In absenta alimentarii cu energie electrica, campul magnetic inceteaza si, in consecinta, arcurile de torsiune imping armatura impotriva discului, franand astfel arborele mecanic. Cuplul de frana se regleaza prin rotirea suruburilor de reglare (8).

The main characteristics of the C Series brake are:

- ◆ Very sturdy structure;
- ◆ Very simple to assemble;
- ◆ Low level noise when working (< 70dB as per Directive 2006/42/EC);
- ◆ Good heat dissipation through the structure formed by aluminium die-casting of and through the electric motor fan;
- ◆ The electromagnetic coil is entirely encased in epoxy resin;
- ◆ The brake is supplied with manual release, on request.

Operation

The brake (fig.4), is designed, when idle, to ensure by means of the torque springs, intrinsic safety equal to and no higher than its stated value, expressed in Nm. When the electromagnet (1) is energised, the armature plate (2) is attracted to it, thus loading the torque springs (4). This allows the disc (6), coupled to the mechanical shaft by way of a splined hub (5), to turn freely. In the absence of power, the magnetic field is eliminated and the torque springs consequently push the armature plate towards the disc, thus brake the mechanical shaft. The brake torque is adjusted by means of the adjusting screws (8).

Specificatiile tehnice ale franelor C / C brakes technical specifications

Tip / Type		C								
		C63	C71	C80	C90	C100	C112	C132	C160/180	C200
cuplu static de franare / static brake torque	(Nm)	4,5	10	16	20	40	60	90	200	400
turatie maxima de rotatie a motorului max motor rotation speed	(rpm)	3600	3600	3600	3600	3600	3600	3600	1500	1500
putere / power	(W)	55	95	105	150	185	380	500	650	650
moment de inertie al franei moment of inertia of the brake	(Kg. cm ²)	0,3 G-AL	0,8 G-AL	1,1 G-AL	3 3	7,6 ALL 11,5 C 40	16 C 40	30 C 40	60 C 40	120 C 40
nivel maxim de sunet / max. sound level	(s dB-A)	70	70	70	69	70	70	70	70	70

Note. Inainte de rodarea franei, valoarea cuplului de frana static se poate modifica cu $\pm 20\%$ fata de valoarea indicata. Valorile afisate in tabel pot fi modificate de producator fara notificare prealabila.

Notes. Before the brake is run in, the static brake torque value could change by $\pm 20\%$ from the value indicated. The values shown in the table may be changed by the manufacture without notice.

(tab. 34)

Reglarea cuplului de franare

Frana din seria C permite reglarea cuplului de franare de funcționare. În funcție de sarcina, viteza de rotație și timpul de frânare, utilizatorul poate seta cuplul de frânare cel mai potrivit cerințelor sale de operare. În tabelul de mai jos, sunt prezentate distanțele aproximative (pe baza toleranțelor componentelor mecanice) în mm de la capul șuruburilor de la electromagnet, pentru a obține cuplul de frânare dorit, care trebuie întotdeauna verificat după asamblarea unității de frânare și înainte de utilizarea pe mașină (vezi desenul). aLLindustrial ajustează frana la aproximativ 80% din valoarea maximă a cuplului. Valoarea maximă a cuplului este ajustată de utilizator prin verificarea funcționării acesteia cu tensiunea minimă (-6% nom.). Dacă sarcina dumneavoastră o permite, reglarea cuplului de frânare sub 100% va aduce o scădere a procentului de uzură a materialului de fricțiune al franei. Tabelul de mai jos corelează valorile în % dintre cuplu și consum.

Brake torque adjustment

The C Series brake allows the operating brake torque to be adjusted. Based on the load, the rotation speed and brake time, the user can set the brake torque best suited to his operating requirements. In the table below, the approximate distances are shown (based on the tolerances of the mechanical components) in mm of the head of the screws from the electromagnet, to obtain the desired brake torque, which should always be checked after the brake unit has been assembled and prior to use on the machine (see drawing). aLLindustrial adjusts the brake to about 80% of the maximum torque value. The maximum torque value is adjusted by the user by checking its operation with the minimum voltage (-6% nom.). If your load allows it, the adjustment of the brake torque below the 100%, will bring a decrease in the percentage of wear in the brake friction material. The table shown below correlates the values in % between torque and consumption.

		C								
		Cuplul de frânare bazat pe valoarea „A” (distanța dintre suprafața superioară a șurubului SHC și suprafața magnetului) brake torque based on value "A" (distance between upper surface of the SHC screw and the surface of the magnet)								
Tip / Type		C63	C71	C80	C90	C100	C112	C132	C160/180	C200
100% max	A (mm)	n.d.	0,3	0,85	1,8	1,1	0,55	-1,3	0,4	0,4
	Cf (Nm)	4,5	10,0	15,0	20,0	40,0	60,0	90,0	200,0	360,0
75%	A (mm)	n.d.	1,8	2,5	3,05	3,1	2,69	0,44	1,26	0,96
	Cf (Nm)	4,5	7,0	11,0	15,0	30,0	45,0	67,0	150,0	270,0
50%	A (mm)	n.d.	3,33	3,99	4,3	5,1	4,84	2,19	3,14	3
	Cf (Nm)	4,5	5,0	7,0	10,0	20,0	30,0	45,0	100,0	180,0

(tab. 35)

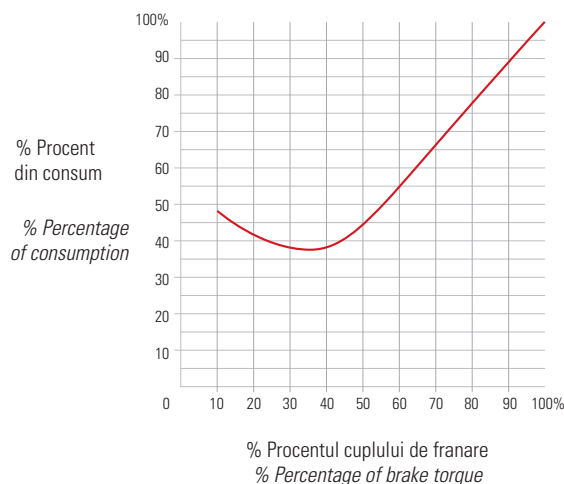
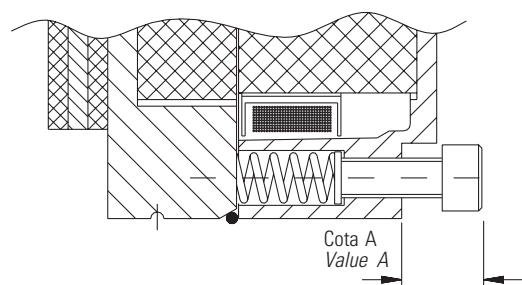

Schema de conectare a franei si tensiunea admisa Brake connection diagram and allowed voltage

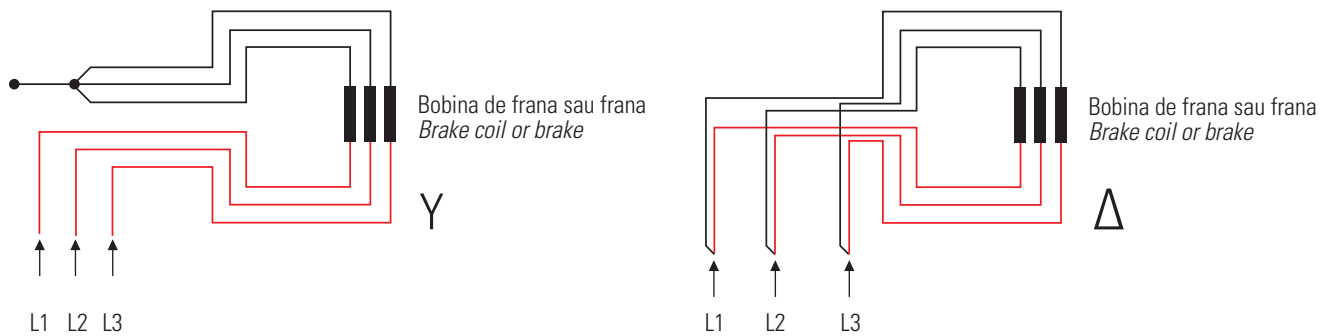

C			
	V _≈ intrare / input L1 - L2 - L3	conexiune / connection	V _≈ frana / brake
tensiuni standard standard voltages	400/50Hz 480/60Hz	Y	400
	230/50Hz 275/60Hz	D	230
tensiuni permise voltages allowed	380-415 /50Hz 460/60Hz	Y	400
	220-240 /50Hz 265/60Hz	D	230

Alte tensiuni furnizate la cerere / Other voltages supplied on request

(tab. 36)

Timpii de interventie / Intervention times

C		
Timpii de interventie Intervention times	Timp de dezactivare electromagnet Electromagnet de-energising time [ms]	Timp de activare electromagnet Electromagnet energising time [ms]
C63	< 10	< 10
C71	< 10	< 10
C80	< 10	< 10
C90	< 10	< 10
C110	< 10	< 10
C132	< 10	< 10
C160/C180/C200	< 10	< 10

(tab. 37)

Limitari importante!

Functionarea corecta a franei poate fi garantata atunci cand functioneaza la temperatura mediului ambiant. Daca frana este utilizata in medii uleioase sau cu temperaturi ridicate, va rugam sa contactati personalul nostru tehnic.

Important limitations!

Correct brake operation can be guaranteed when operating at environmental temperature. If the brake is used in oily or high-temperature environments, we kindly request that you contact our technical staff.

Intretinere si reparatii

Toate componentele franei trebuie verificate frecvent, deoarece lucrul mecanic la frecare depinde de o serie de factori, in principal de inertia sarcinii, viteza motorului si frecventa de functionare. Discul trebuie inlocuit odata ce materialul de frecare a fost consumat cu 3 mm. Cand spatiul liber atinge o valoare egala cu 0,7 mm, valoarea respectiva trebuie adusa la 0,2 mm. Asigurati-va ca, dupa inspectie, spatiul liber este reglat corect. Distanța libera poate fi reglata prin modificarea suruburilor de reglare (3) si a suruburilor de fixare (9). Efectuati operatiunile de service si reparatii atunci cand frana este deconectata si dupa verificarea impamantarii. Functionarea corecta a franei poate fi garantata numai cu utilizarea componentelor originale furnizate de aLLindustrial.

Reglarea spatiului liber

Reglarea spatiului liber se poate efectua prin modificarea suruburilor de fixare (9) dupa slabirea suruburilor de reglare (3). Va rugam sa asteptati o perioada de racire inainte de a regla spatiul liber dupa utilizarea franei. Valoarea maxima admisa a spatiului liber este de 0,7 mm. Daca aceasta valoare este depasita din cauza consumului de material de frictiune, performanta franei poate fi afectata. Mai mult, depasirea valorii maxime a intrefierului va duce la o deteriorare a performantei franei, rezultand in nedeschiderea franei in timpul rotatiei motorului, provocand supraincalzirea motorului si a franei.

Maintenance and repairs

All parts of the brake must be checked frequently as the friction work depends on a number of factors, mainly on the load inertia, the motor speed, and the operating frequency. The disc must be replaced once the friction material has been consumed by 3 mm. When the air-gap reaches a value equal to 0.7 mm, said value must be brought to 0.2 mm. Make sure that after the inspection the air-gap is correctly adjusted. The air-gap can be adjusted by altering the adjusting screws (3) and the fixing screws (9). Carry out servicing and repair operations when the brake is disconnected and after checking the earthing. The proper working order of the brake can only be guaranteed with the use of original components supplied by aLLindustrial.

Air-gap regulation

Adjusting the air-gap can be carried out by altering the fixing screws (9) after loosening the adjusting screws (3). Please allow for a cooling down period before adjusting the air-gap after using the brake. The maximum allowed value of the air-gap is 0.7 mm. If this value is exceeded due to the consumption of friction material, brake performance may be affected. Moreover, exceeding the maximum value of the air-gap will lead to a deterioration in the performance of the brake, resulting in the failure of the brake to open during motor rotation, causing the motor and the brake to overheat.

Curbe limita maxima de lucru Seria C / Maximum work limit curves C Series

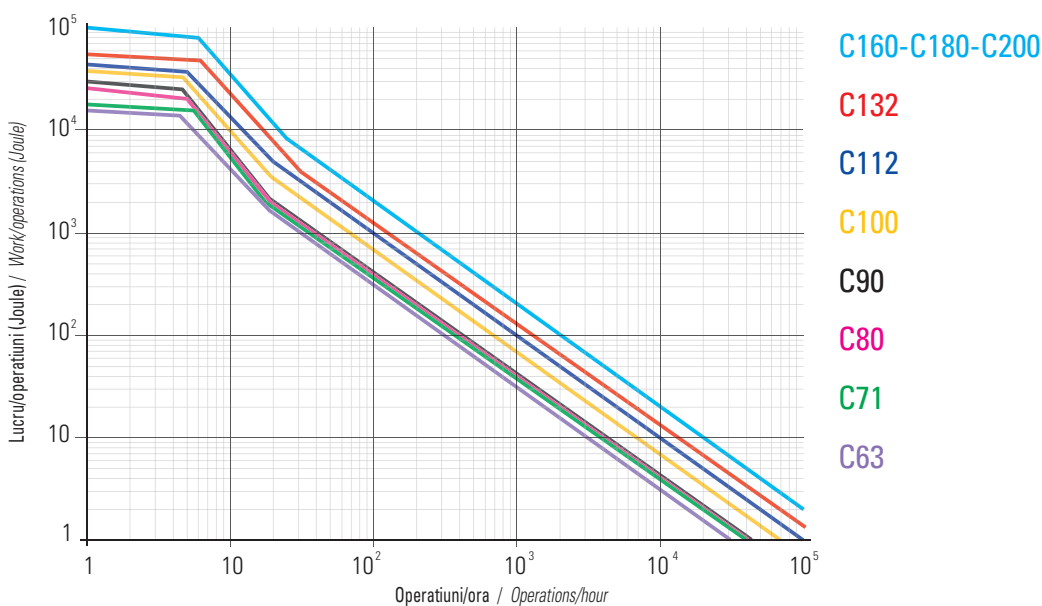

Nota: valorile de disipatie indicate in grafic sunt valabile numai pentru vitezele de rotatie raportate in tabel.
Note: the dissipation values indicated in the graph are valid only for the rotation speeds reported in the table.

◆ 5.8 Motor cu frana trifazat, cu o viteza

Three-phase brake motor, single polarity

2 POLI / 2 POLES TS TC TK 3000rpm													
Type	kW	HP	rpm	$\eta\%$ 100%	cos φ	In (A) 400V 50Hz	Is — In	Cn	Cs — Cn	CMax — Cn	Kg	Cf Brake torque Nm S	Cf Brake torque Nm C / K
6... 63A2	0,18	0,25	2710	63,0	0,75	0,55	6	0,63	2,2	2,4	4	3,5	4,5 / 5
6... 63B2	0,25	0,34	2710	65,0	0,78	0,71	6	0,88	2,2	2,4	4,4	3,5	4,5 / 5
6... 63C2	0,37	0,5	2710	65,0	0,78	1,05	6	1,3	2,2	2,4	4,9	3,5	4,5 / 5
6... 71A2	0,37	0,5	2730	70,0	0,79	0,97	6	1,3	2,2	2,4	5,6	5,5	10 / 12
6... 71B2	0,55	0,75	2760	71,0	0,79	1,42	6	1,9	2,2	2,4	6,1	5,5	10 / 12
6... 71C2	0,75	1	2730	72,0	0,82	1,83	6	2,63	2,2	2,4	7	5,5	10 / 12
6... 80A2	0,75	1	2770	73,0	0,84	1,77	6	2,59	2,2	2,4	9,1	11	16
6... 80B2	1,1	1,5	2770	76,2	0,83	2,51	6	3,79	2,2	2,4	10,2	11	16
6... 80C2	1,5	1,5	2800	78,5	0,83	3,32	6	5,12	2,2	2,4	11,7	11	16
6... 90S2	1,5	2	2840	78,5	0,84	3,28	6	5,05	2,2	2,4	12	12	20
6... 90L2	2,2	3	2840	81,0	0,85	4,61	6	7,4	2,2	2,4	15	12	20
6... 90LB2	3	4	2840	82,6	0,86	6,1	6	10,09	2,2	2,4	18,5	12	20
6... 100L2	3	4	2840	82,6	0,87	6,03	7	10,09	2,2	2,3	22,3	21	40
6... 100LB2	4	5,5	2850	84,6	0,87	7,88	7,5	13,41	2,2	2,3	25,2	21	40
6... 112M2	4	5,5	2880	84,2	0,87	7,88	7,5	13,27	2,2	2,3	26,7	22	60
6... 112MB2	5,5	7,5	2880	85,7	0,88	10,53	7,5	18,25	2,2	2,3	30,2	22	60
6... 132SA2	5,5	7,5	2900	85,7	0,88	10,53	7,5	18,12	2	2,2	38,5	23	90
6... 132SB2	7,5	10	2920	87,0	0,88	14,14	7,5	24,54	2	2,2	42,2	23	90
6... 132MA2	9,2	12,5	2930	88,0	0,89	17,25	7,5	30	2	2,2	51,4	23	90
6... 132MB2	11	15	2930	88,4	0,90	19,96	7,5	35,87	2	2,2	60,4	23	90
7... 160MA2	11	15	2930	88,7	0,89	19,5	6,7	35,8	2,6	2,9	101	50	200
7... 160MB2	15	20	2930	89,5	0,90	26,5	6,7	48,8	2,6	2,9	111	50	200
7... 160L2	18,5	25	2930	90,2	0,90	32,4	6,8	60,4	2,5	2,8	126	50	200
7... 160LB2	22	30	2930	90,4	0,90	37,6	6,8	71,4	2,5	2,8	158	50	200
7... 180M2	22	30	2940	90,6	0,90	38,8	6,6	71,4	2,6	2,8	176	50	200
7... 180MB2	30	40	2950	91,0	0,90	52,5	6,6	96,9	2,6	2,8	190	50	200
7... 200LA2	30	40	2950	91,5	0,90	53,1	6,5	97,2	2,5	2,7	226		400
7... 200LB2	37	50	2950	92,0	0,90	63,9	6,5	119,8	2,4	2,6	245		400
7... 225M2	45	60	2970	92,5	0,90	77,8	6,8	144,8	2,4	2,6	280		600
7... 250M2	55	75	2970	93,2	0,90	95,8	6,8	177	2,5	2,8	379		800
7... 280S2	75	100	2970	93,9	0,90	126,8	6,7	241,3	2,4	2,7	512		1000
7... 280M2	90	125	2970	94,2	0,91	151,5	6,7	289,5	2,4	2,7	578		1000

Datele tehnice si performantele se pot modifica / Technical data and performances may change

5. Motoare cu frana

4 POLI / 4 POLES TS TC TK 1500rpm

Type	kW	HP	rpm	$\eta\%$ 100%	$\cos\varphi$	I_n (A) 400V 50Hz	I_s — I_n	C_n	C_s — C_n	C_{Max} — C_n	Kg	Cf Brake torque Nm S	Cf Brake torque Nm C / K
6... 63A4	0,12	0,16	1350	57	0,64	0,47	6	0,85	2,2	2,4	3,9	3,5	4,5 / 5
6... 63B4	0,18	0,25	1350	59	0,65	0,68	6	1,27	2,2	2,4	4,3	3,5	4,5 / 5
6... 63C4	0,25	0,34	1350	60	0,66	0,91	6	1,77	2,2	2,4	4,8	3,5	4,5 / 5
6... 71A4	0,25	0,34	1350	60	0,72	0,84	6	1,77	2,2	2,4	5,4	5,5	10 / 12
6... 71B4	0,37	0,5	1370	65	0,74	1,11	6	2,58	2,2	2,4	6,2	5,5	10 / 12
6... 71C4	0,55	0,75	1380	66	0,75	1,6	6	3,81	2,2	2,4	7,3	5,5	10 / 12
6... 80A4	0,55	0,75	1370	67	0,75	1,58	6	3,84	2,2	2,4	9	11	16
6... 80B4	0,75	1	1380	72	0,78	1,93	6	5,19	2,2	2,4	10	11	16
6... 80C4	1,1	1,5	1390	76,2	0,78	2,67	6	7,56	2,2	2,4	12,3	11	16
6... 90S4	1,1	1,5	1400	76,2	0,79	2,64	6	7,51	2,2	2,4	12,1	12	20
6... 90L4	1,5	2	1400	78,5	0,8	3,45	6	10,24	2,2	2,4	14,6	12	20
6... 90LB4	2,2	3	1400	81	0,8	4,9	7	15,02	2,2	2,4	18,3	12	20
6... 100LA4	2,2	3	1420	81	0,81	4,84	7	14,8	2,2	2,3	21	21	40
6... 100LB4	3	4	1420	82,6	0,81	6,47	7	20,19	2,2	2,3	24,7	21	40
6... 100LC4	4	5,5	1430	84,6	0,82	8,36	7	26,73	2,2	2,3	29	21	40
6... 112M4	4	5,5	1430	84,2	0,83	8,26	7	26,73	2,2	2,2	30,5	22	60
6... 112MB4	5,5	7,5	1440	85,7	0,83	11,16	7	36,49	2,2	2,2	34,8	22	60
6... 132S4	5,5	7,5	1450	85,7	0,84	11,03	7	36,24	2,2	2,2	40,4	23	90
6... 132M4	7,5	10	1450	87	0,85	14,64	7	49,42	2,2	2,2	49,6	23	90
6... 132MA4	9,2	12,5	1460	87,5	0,85	17,85	7,5	60,21	2,2	2,2	56,5	23	90
6... 132MB4	11	15	1460	88,4	0,86	20,88	7,5	71,99	2,2	2,2	64	23	90
7... 160M4	11	15	1460	88,6	0,84	21,1	6,9	72	2,3	2,9	109	50	200
7... 160L4	15	20	1460	89,5	0,85	28,3	6,8	98,2	2,3	2,9	130	50	200
7... 160LB4	18,5	25	1455	90,9	0,86	33,6	6,8	120	2,3	2,9	137	50	200
7... 180M4	18,5	25	1470	90,2	0,86	34,4	6,4	120,2	2,3	2,9	165	50	200
7... 180L4	22	30	1470	90,7	0,86	39,4	6,9	143	2,3	2,9	180	50	200
7... 180LB4	30	40	1475	91,6	0,86	52,8	6,9	195	2,3	2,9	137	50	200
7... 200L4	30	40	1470	92,1	0,86	52,8	6,8	195	2,4	2,9	240		400
7... 225S4	37	50	1480	92,7	0,87	64,2	6,5	238,9	2,2	2,7	278		600
7... 225M4	45	60	1480	93	0,87	78,6	6,3	290,5	2,3	2,5	308		600
7... 250M4	55	75	1480	93,3	0,87	97,8	6,4	355,1	2,2	2,5	402		800
7... 280S4	75	100	1480	93,8	0,88	131,3	6,8	483,9	2,1	2,8	540		1000
7... 280M4	90	125	1480	94,1	0,88	154,3	6,9	580,7	2,2	2,7	615		1000

Datele tehnice si performantele se pot modifica / Technical data and performances may change

6 POLI / 6 POLES TS TC TK 1000rpm													
Type	kW	HP	rpm	$\eta\%$ 100%	cos φ	In (A) 400V 50Hz	Is — In	Cn	Cs — Cn	CMax — Cn	Kg	Cf Brake torque Nm S	Cf Brake torque Nm C / K
6... 63A6	0,09	0,16	840	42	0,61	0,51	3,5	1,02	2	2	4,2	3,5	4,5 / 5
6... 63B6	0,12	0,16	850	45	0,62	0,62	3,5	1,35	2	2	4,8	3,5	4,5 / 5
6... 71A6	0,18	0,25	880	56	0,66	0,7	4	1,95	1,6	1,7	6	5,5	10 / 12
6... 71B6	0,25	0,34	900	59	0,7	0,87	4	2,65	2,1	2,2	6,5	5,5	10 / 12
6... 71C6	0,37	0,5	890	61	0,69	1,27	4	3,97	2	2,1	7,2	5,5	10 / 12
6... 80A6	0,37	0,5	900	62	0,7	1,23	4	3,93	1,9	1,9	8,2	11	16
6... 80B6	0,55	0,75	900	67	0,72	1,65	4	5,84	2	2,3	9,9	11	16
6... 80C6	0,75	1	900	68	0,72	2,21	4	7,96	2	2,3	11,3	11	16
6... 90S6	0,75	1	920	69	0,72	2,18	5,5	7,79	2,2	2,2	11,7	12	20
6... 90L6	1,1	1,5	925	72	0,73	3,02	5,5	11,36	2,2	2,2	15,1	12	20
6... 100L6	1,5	2	945	74	0,76	3,85	6	15,17	2,2	2,2	19,1	21	40
6... 112M6	2,2	3	955	78	0,76	5,36	6	22,01	2,2	2,2	25,4	22	60
6... 132S6	3	4	960	79	0,76	7,21	6,5	29,86	2	2	36,1	23	90
6... 132MA6	4	5,5	960	80,5	0,76	9,44	6,5	39,81	2	2	45	23	90
6... 132MB6	5,5	7,5	960	83	0,77	12,42	6,5	54,74	2	2	55,5	23	90
6... 132MC6	7,5	10	960	85	0,77	16,54	6,5	74,65	2	2	60	23	90
7... 160M6	7,5	10	970	86,6	0,77	15,9	5,6	73,9	2	2,6	103	50	200
7... 160L6	11	15	970	87,6	0,78	22,8	5,8	108,3	2,1	2,4	121	50	200
7... 180L6	15	20	970	89	0,81	29,4	5,7	147,7	2	2,4	173	50	200
7... 200LA6	18,5	25	970	90,2	0,81	36,6	6,7	182,2	2,2	2,8	221		400
7... 200LB6	22	30	970	90,2	0,83	40,9	6,6	216,7	2,3	2,9	236		400
7... 225M6	30	40	980	91,5	0,84	56,4	6,8	292,5	2,2	2,7	301		600
7... 250M6	37	50	980	92,2	0,86	67,4	6,2	360,7	2	2,5	370		800
7... 280S6	45	60	980	92,5	0,86	82	6,1	438,7	1,9	2,5	478		1000
7... 280M6	55	75	980	92,9	0,86	100	6,7	536,2	2,1	2,7	535		1000
7... 280MB6	75	100	985	93,6	0,87	133	5,8	727,2	2,1	2,3	682		1000

Datele tehnice si performantele se pot modifica / Technical data and performances may change

5. Motoare cu frana

8 POLI / 8 POLES TS TC TK 750rpm

Type	kW	HP	rpm	$\eta\%$ 100%	$\cos\varphi$	I_n (A) 400V 50Hz	I_s — I_n	C_n	C_s — C_n	C_{Max} — C_n	Kg	Cf Brake torque Nm S	Cf Brake torque Nm C / K
6... 71A8	0,09	0,12	680	48	0,56	0,48	3	1,26	1,5	1,7	6	5,5	10 / 12
6... 71B8	0,12	0,16	690	51	0,59	0,58	2,7	1,66	1,6	1,7	6,8	5,5	10 / 12
6... 80A8	0,18	0,25	680	51	0,61	0,84	2,8	2,53	1,5	1,7	9,9	11	16
6... 80B8	0,25	0,34	680	56	0,61	1,06	2,7	3,51	1,6	2	10,9	11	16
6... 90S8	0,37	0,5	680	63	0,63	1,35	2,8	5,2	1,6	1,8	14,8	12	20
6... 90L8	0,55	0,75	680	66	0,65	1,85	3	7,73	1,6	1,8	17,2	12	20
6... 100LA8	0,75	1	710	66	0,67	2,45	3,5	10,09	1,7	2,1	17,5	21	40
6... 100LB8	1,1	1,5	710	72	0,69	3,2	3,5	14,8	1,7	2,1	19,7	21	40
6... 112M8	1,5	2	710	74	0,68	4,3	4,2	20,19	1,8	2,1	25,6	22	60
6... 132S8	2,2	3	720	75	0,71	5,96	5,5	29,2	2	2	35,5	23	90
6... 132M8	3	4	720	77	0,73	7,7	5,5	39,81	2	2	45	23	90
7... 160MA8	4	5,5	720	81,6	0,73	9,7	4,4	53,1	2,2	2,5	90	50	200
7... 160MB8	5,5	7,5	720	83,3	0,74	12,9	5	73	2,2	2,4	102	50	200
7... 160L8	7,5	10	720	85,9	0,75	16,8	5,7	99,5	2,1	2,3	122	50	200
7... 180L8	11	15	720	87,8	0,75	24,1	5,6	144	2,3	2,5	150	50	200
7... 200L8	15	20	730	88,3	0,76	32,3	5,5	196,3	2,1	2,4	212		400
7... 225S8	18,5	25	730	90,2	0,76	39	5,6	242,1	2,2	2,6	285		600
7... 225M8	22	30	740	90,8	0,78	44,8	5,4	284	2,1	2,4	385		600
7... 250M8	30	40	740	91,2	0,79	60,1	5,3	387,3	2,2	2,5	378		800
7... 280S8	37	50	740	91,8	0,79	73,6	5,6	477,7	2,3	2,7	485		1000
7... 280M8	45	60	740	92	0,79	89,4	5,2	581	2,1	2,8	568		1000

Datele tehnice si performantele se pot modifica / Technical data and performances may change

2 POLI / 2 POLES 1TC 1TK 3000rpm

Type	kW	HP	rpm	$\eta\%$ 100% 50Hz	$\cos\varphi$	I_n (A) 400V	I_s — I_n	C_n	C_s — C_n	C_{Max} — C_n	Kg	Cf Brake torque Nm C / K
1... 80B2	1,1	1,5	2798	78,3	0,85	2,39	5,6	3,75	2,4	2,6	16	16
1... 90S2	2,2	3	2798	79,0	0,87	4,54	6,3	5,12	2,8	3,2	20	20
1... 100L2	3	4	2800	82,6	0,89	5,9	6,2	10,2	2,8	2,8	31	40
1... 112M2	4	5,5	2840	86,0	0,89	10,4	7,6	18,5	2,6	2,9	45	60

4 POLI / 4 POLES 1TC 1TK 1500rpm

1... 71A4	0,25	0,34	1360	67,4	0,71	0,76	3,6	1,76	2,6	2,8	9,5	10 / 12
1... 71B4	0,37	0,5	1357	67,6	0,73	1,08	3,8	0,5	2,5	2,5	10	10 / 12
1... 80A4	0,55	0,75	1386	73,4	0,75	1,45	4,7	3,79	2,5	2,5	14	16
1... 80B4	0,75	1	1403	73,6	0,74	2,1	4,6	5,1	2,6	2,7	15	16
1... 90S4	1,1	1,5	1375	77,1	0,81	2,54	4,7	7,64	2,4	2,4	19	20
1... 90L4	1,5	2	1386	81,6	0,80	3,39	5,4	10,3	2,7	3	23	20
1... 100LA4	2,2	3	1400	82,1	0,84	4,66	5,9	15	2,5	2,7	27	40
1... 100LB4	3	4	1402	82,9	0,85	6,2	6,2	20,4	2,6	2,6	34	40
1... 112M4	4	5,5	1428	84,3	0,81	8,47	6	26,8	2,4	2,7	43	60
1... 132S4	5,5	7,5	1429	85,7	0,84	11	6,2	36,8	2,3	2,7	49	90
1... 132M4	7,5	10	1442	87,2	0,83	15	7,4	49,7	2,5	2,9	57	90

6 POLI / 6 POLES 1TC 1TK 1000rpm

1... 80B6	0,55	0,75	903	65,4	0,71	1,72	3,7	5,82	2,1	2,2	16	16
1... 90L6	1,1	1,5	910	73,9	0,74	2,92	4,2	11,5	2,3	2,3	19	20
1... 100L6	1,5	2	914	74,9	0,74	2,56	4,7	15,7	2,1	2,2	24	40
1... 112M6	2,2	3	933	79,2	0,75	3,25	5,3	22,5	2,1	2,4	30	60

Datele tehnice si performantele se pot modifica / Technical data and performances may change

◆ 5.9 Performanta motorului cu frana trifazat, cu polaritate dubla (2 viteze)

Performance of three-phase brake motor, double polarity

2/4 POLI / 2/4 POLES PS PC PK 3000/1500rpm Conexiune Dahlander / Dahlander connection															
Type	kW	HP	rpm	$\eta\%$ 100%	$\cos\varphi$	I_n (2p)	I_n (4p)	I_s/I_n (2p)	I_s/I_n (4p)	Cs/Cn (2p)	Cs/Cn (4p)	kg S	Cf Brake torque Nm C / K	Cf Brake torque Nm	
6... 71A	0,30/0,22	0,41/0,3	2760/1410	68/69	0,90/0,82	1,3	0,9	3,2	3	1,7	1,8	6	5,5	10/12	
6... 71B	0,45/0,3	0,61/0,41	2720/1390	68/69	0,90/0,82	1,6	1,1	3,7	3,5	2	2	6,1	5,5	10/12	
6... 80A	0,59/0,44	0,8/0,6	2730/1390	70/71	0,91/0,84	1,8	1,3	3,8	4	2	2	10	11	16	
6... 80B	0,81/0,59	1,1/0,8	2800/1420	72/73	0,91/0,94	2,6	2	5	4	2	2	11	11	16	
6... 90S	1,32/1	1,8/1,36	2770/1380	69/67	0,91/0,80	3,7	2,65	3,8	3,8	1,8	1,7	13	12	20	
6... 90L	2/1,32	2,7/1,8	2780/1380	72/70	0,91/0,79	4,7	3,5	4	4,2	2	1,8	14	12	20	
6... 100LA	2,4/1,8	3,2/2,4	2880/1420	77/79	0,90/0,82	5,9	4,5	4,4	4,6	2,2	2	21	21	40	
6... 100LB	3,1/2,4	4,2/3,3	2860/1400	79/80	0,90/0,84	8,3	6,1	5	5,2	2,2	2,1	24	21	40	
6... 112M	4,2/3,2	5,7/4,3	2900/1430	80/83	0,93/0,87	11	7,5	5,5	5,5	2,2	2,1	28	22	60	
6... 132S	5,5/4,5	7,5/6,1	2900/1450	77,5/81,5	0,93/0,89	11,5	9,5	6,5	6	2,3	2,2	42	23	90	
6... 132M	7,5/6,2	10,2/8,4	2910/1450	81/83	0,93/0,89	17	13,5	7	6	2,3	2,2	51	23	90	
6... 132MA	9,5/7,5	13/10	2910/1450	81/84	0,93/0,90	20	16	7	6	2,3	2,2	54	23	90	
7... 160M	11/8,8	15/12	2930/1460	81/88	0,90/0,86	24	20	7,3	6	2,3	2,2	118	50	200	
7... 160L	15/11,8	20/16	2930/1460	87/89	0,93/0,98	30	26	8	7	1,8	2,2	130	50	200	
7... 180M	18,5/15	25/20	2930/1460	87/88	0,91/0,89	36,2	30	8	7,6	2,5	2,4	165	50	200	
7... 180L	22/18,5	30/25	2950/1460	86/87	0,90/0,91	43	37,2	8	7,8	2	2	181	50	200	
7... 200L	30/22	40/30	2930/1460	86/87	0,93/0,91	57	44	6,8	6,7	2	1,8	245		400	
7... 225S	38/32	51,7/43,5	2930/1460	87/89	0,91/0,89	70	60	6,8	6,7	2	1,8	258		600	
7... 225M	45/38	60/51,7	2930/1460	87/88	0,93/0,89	84	64	6,8	6,7	2	1,8	290		600	
7... 250M	55/45	75/60	2940/1465	87/88	0,90/0,87	100	76	7	6,5	2,1	1,7	388		800	
7... 280S	70/55	95/75	2945/1470	87/88	0,90/0,89	128	100	6,9	6,4	2	1,7	510		1000	
7... 280M	85/70	116/95	2945/1470	87/88	0,91/0,89	148	131	6,9	6,3	2	1,7	606		1000	

4/8 POLI / 4/8 POLES PS PC PK 1500/750rpm Conexiune Dahlander / Dahlander connection															
Type	kW	HP	rpm	$\eta\%$ 100%	$\cos\varphi$	I_n (4p)	I_n (8p)	I_s/I_n (4p)	I_s/I_n (8p)	Cs/Cn (4p)	Cs/Cn (8p)	kg S	Cf Brake torque Nm S	Cf Brake torque Nm C / K	
6... 71B	0,2/0,1	0,27/0,14	1370/660	73/51	0,87/0,62	0,65	0,7	3	2,5	1,7	1,7	7	5,5	10/12	
6... 80A	0,3/0,15	0,4/0,2	1350/680	74/50	0,87/0,62	1	1,1	3,5	2,5	1,7	1,9	9,5	11	16	
6... 80B	0,37/0,22	0,5/0,3	1370/680	72/53	0,87/0,62	1,4	1,5	3,5	3	1,7	1,9	10	11	16	
6... 90S	0,7/0,37	0,95/0,5	1350/680	72/58	0,89/0,60	1,8	1,9	3,5	3	1,7	1,8	12	12	20	
6... 90L	1,03/0,55	1,4/0,75	1340/680	72/60	0,89/0,65	2,5	2,5	3,7	3	1,7	1,9	13	12	20	
6... 100LA	1,25/0,7	1,7/0,95	1400/700	76/64	0,89/0,62	3,2	3	4	3	1,5	1,5	22	21	40	
6... 100LB	1,6/0,88	2,2/1,2	1420/690	79/66	0,88/0,61	3,9	3,7	4,5	3	1,7	1,7	24	21	40	
6... 112M	2,4/1,5	3,3/2	1370/680	81/73	0,89/0,65	5,5	4,8	4,5	3,5	1,7	1,8	26	22	60	
6... 132S	3,3/2,2	4,5/3	1420/690	80/75	0,91/0,67	8	6	5	4	1,7	1,8	46	23	90	
6... 132MA	4,4/3	6/4	1410/690	82/78	0,91/0,65	9,8	10,5	5,5	4	1,7	1,8	50	23	90	
6... 132MB	5,5/4	7,5/5,5	1410/690	82/79	0,90/0,66	12	11	5,5	4	1,7	1,8	51	23	90	
7... 160MA	7,5/4,8	10/6,5	1430/710	87/80	0,90/0,61	16,9	12,8	6	5	1,8	1,8	101	50	200	
7... 160MB	8,1/5,5	11/7,5	1430/710	88/81	0,90/0,62	17,6	13,8	6	5	1,8	1,8	102	50	200	
7... 160L	10,3/6,6	14/9	1450/720	87/85	0,92/0,68	21	15,3	7	5,5	2	2	103,7	50	200	
7... 180M	11,8/7,5	16/10	1450/720	85/83	0,90/0,67	23,3	17	7,5	6	2	2	159	50	200	
7... 180L	15/9,2	20/12,5	1450/720	86/84	0,90/0,66	29,8	21	7,5	6	2	2,1	163	50	200	
7... 200LA	18,5/11,8	25/16	1455/725	86/84	0,91/0,69	37	24	6,8	5,6	2,2	2,1	226		400	
7... 200LB	22/15	30/20	1455/725	86/84	0,91/0,70	42	36	6,8	5,6	2,2	2,1	228		400	
7... 225S	30/19	40/26	1455/725	88/85	0,90/0,71	55	44	6,9	5,6	2,2	2,1	242		600	
7... 225M	33,8/22	46/30	1455/725	88/85	0,90/0,71	63	52	6,8	5,5	2,1	2	265		600	
7... 250M	40/27	55/37	1460/730	87/85	0,89/0,71	74	63	6,9	5,5	2,1	2	357		800	
7... 280S	48/32	65/44	1460/730	89/88	0,88/0,70	87	72	7	5,7	2,3	2,1	469		1000	
7... 280M	56/38	76/52	1460/730	88/86	0,89/0,70	100	82	7	5,8	2,3	2,1	472		1000	

Datele tehnice si performantele se pot modifica / Technical data and performances may change

5. Motoare cu frana

4-6 POLI / 4-6 POLES PS PC PK 1500-1000rpm infasurare separata / separated winding

Type	kW	HP	rpm	$\eta\%$ 100%	$\cos\varphi$	In (4p)	In (6p)	Is/In (4p)	Is/In (6p)	Cs/Cn (4p)	Cs/Cn (6p)	kg	Cf Brake torque Nm S	Cf Brake torque Nm C/K
6... 80A	0,37/0,22	0,5/0,3	1420/920	70/59	0,84/0,74	1,3	0,97	4	3	1,8	1,8	10,5	11	16
6... 80B	0,45/0,3	0,6/0,4	1420/930	69/59	0,83/0,77	1,5	1,3	4,3	3,5	1,9	1,9	11	11	16
6... 90S	0,66/0,45	0,9/0,6	1420/930	68/59	0,85/0,79	1,9	1,8	4,1	3,1	1,8	1,5	13	12	20
6... 90L	0,95/0,59	1,3/0,8	1420/940	71/62	0,84/0,77	2,8	2,2	4,1	3,1	1,8	1,5	14,5	12	20
6... 100LA	1,32/0,88	1,8/1,2	1440/940	74/71	0,79/0,76	3,6	2,8	4,5	3,5	1,6	1,6	21	21	40
6... 100LB	1,7/1,2	2,3/1,6	1450/940	75/73	0,79/0,76	5,2	3,8	4,5	3,5	1,6	1,6	23	21	40
6... 112M	2,2/1,5	3/2	1450/950	80/75	0,80/0,72	6,5	4,5	5,3	4,2	1,6	1,6	27	22	60
6... 132S	3,4/2,4	4,7/3,2	1460/960	80/76	0,88/0,75	8	6	5,5	4,5	1,8	1,7	41	23	90
6... 132MA	4,6/3,2	6,2/4,3	1460/960	82/77	0,89/0,78	10	8,3	5,5	4,5	1,8	1,7	45	23	90
6... 132MB	5,1/3,3	7/4,5	1460/960	83/78	0,89/0,78	11	8,6	5,5	4,4	1,8	1,7	49	23	90
7... 160M	6,6/4,5	9/6	1470/970	86/83	0,89/0,81	14	11	6,4	4,6	2,1	1,9	117	50	200
7... 160L	8,8/5,9	12/8	1470/970	89/85	0,89/0,82	18,5	15	6,8	5,4	2,3	2,2	141	50	200
7... 180M	11/7,5	15/10	1470/980	86/83	0,89/0,81	23	18	6,8	5,6	2,3	2,3	170	50	200
7... 180L	13,2/8,8	18/12	1480/980	87/83	0,89/0,82	27	21	7	5,6	2,3	2,3	174	50	200
7... 200LA	18,5/13,2	25/18	1470/975	87/83	0,88/0,82	37	28	6,4	6,1	2,2	2,2	200		400
7... 200LB	22/15	30/20	1470/975	88/83	0,89/0,82	44	32	6,5	6,1	2,2	2,2	221		400
7... 225S	26/16	35/22	1470/975	88/81	0,89/0,80	49	35	6,5	6,1	2,1	2,1	255		600
7... 225M	30/19	40/26	1470/975	88/81	0,88/0,79	56	40	6,6	6	2	2,1	265		600
7... 250M	33/22	45/30	1475/980	89/83	0,89/0,82	60	47	6,5	6	2,1	2,2	362		700
7... 280S	40/26	55/35	1475/980	87/82	0,89/0,83	75	53	6,4	6,2	2,2	2,1	490		1000
7... 280M	50/33	68/45	1475/980	87/82	0,89/0,83	95	71	6,3	6,1	2	2,1	540		1000

6-8 POLI / 6-8 POLES PS PC PK 1000-750rpm infasurare separata / separated winding

Type	kW	HP	rpm	$\eta\%$ 100%	$\cos\varphi$	In (6p)	In (8p)	Is/In (6p)	Is/In (8p)	Cs/Cn (6p)	Cs/Cn (8p)	kg	Cf Brake torque Nm S	Cf Brake torque Nm C/K
6... 80A	0,18/0,13	0,25/0,18	920/630	56/51	0,76/0,69	0,78	0,65	2,7	2	1,5	1,8	8,7	11	16
6... 80B	0,26/0,15	0,35/0,2	920/630	57/51	0,76/0,69	1,12	0,75	2,7	2	1,5	1,8	10,5	11	16
6... 90S	0,37/0,28	0,5/0,38	930/690	57/50	0,77/0,70	1,6	1,4	3	3	1,5	1,8	12	12	20
6... 90L	0,59/0,3	0,8/0,4	930/700	62/53	0,74/0,68	2,15	1,5	3,3	3	1,5	1,8	13,7	12	20
6... 100LA	0,81/0,55	1,1/0,75	950/700	67/55	0,77/0,63	2,7	2,1	3,8	3,3	1,5	1,8	22	21	40
6... 100LB	1,03/0,66	1,4/0,9	950/700	68/56	0,76/0,64	3,3	2,5	3,8	3,3	1,5	1,8	24	21	40
6... 112M	1,4/1,03	1,9/1,4	960/705	71/55	0,74/0,66	4,4	3,6	4,5	4	1,5	1,8	27	22	60
6... 132S	1,84/1,32	2,5/1,8	970/720	78/70	0,72/0,67	5,2	4	5	4,5	1,7	1,9	43	23	90
6... 132MA	2,6/1,84	3,5/2,5	975/725	78/70	0,72/0,66	7,4	5,7	5,5	4,5	2	1,9	54	23	90
6... 132MB	3/2	4/2,7	975/725	78/71	0,72/0,67	8,5	6	5,3	5	2	1,9	59	23	90
7... 160M	4/2,6	5,5/3,5	980/730	79/71	0,74/0,69	11	7,5	6,5	5,1	1,8	1,9	104	50	200
7... 160L	5,5/4	7,5/5,5	980/730	79/71	0,73/0,69	13	10	6,8	5,1	1,8	1,8	112	50	200
7... 180M	6,6/5,1	9/7	950/720	79/72	0,70/0,69	16	13,5	6,8	5,5	1,7	1,8	144	50	200
7... 180L	8,1/5,9	11/8	950/720	79/72	0,70/0,69	18	15	6,8	5,5	1,7	1,8	159	50	200
7... 200LA	11/8,1	15/11	980/730	78/71	0,71/0,68	23	18	6	5,6	1,8	1,8	170		400
7... 200LB	13,2/9,5	18/13	980/730	78/71	0,71/0,68	30	24	6	5,6	1,8	1,8	227		400
7... 225S	16/13,2	22/18	980/730	77/71	0,73/0,69	35	30	5,9	5,5	1,7	1,7	233		600
7... 225M	22/17	30/23	980/730	77/72	0,73/0,69	46	38	5,8	5,4	1,7	1,7	241		600
7... 250M	30/22	40/30	980/730	78/74	0,72/0,68	65	50	6,1	5,6	1,8	1,8	366		700
7... 280S	35/26	48/36	980/735	79/73	0,72/0,68	76	58	6	5,4	1,7	1,7	470		1000
7... 280M	41/33	56/45	980/735	79/73	0,74/0,67	82	74	6,1	5,5	1,7	1,8	536		1000

Datele tehnice si performantele se pot modifica / Technical data and performances may change

◆ 5.10 Performanta motorului cu frana monofazat

Performance of single-phase brake motor

2 POLI / 2 POLES 6MS 6MK 3000rpm condensator de functionare / run capacitor														
Type	kW	HP	rpm	$\eta\%$	cos ϕ	I_n	I_s/I_n	C_n	C_s/C_n	C_{max}/C_n	Run Cap. (μ F)	kg	Cf Brake torque Nm 6MS	Cf Brake torque Nm 6MK
6... 63A2	0,18	0,25	2780	60,00	0,92	1,418	4,94	0,62	0,7	1,7	10	4	3,5	5
6... 63B2	0,25	0,34	2780	61,00	0,92	1,937	5,16	0,86	0,68	1,7	12	4,5	3,5	5
6... 63C2	0,37	0,5	2740	68,00	0,99	2,390	3,50	1,29	0,7	1,8	16	5,3	3,5	5
6... 71A2	0,37	0,5	2800	63,00	0,93	2,746	4,37	1,26	0,65	1,7	20	5,1	5,5	12
6... 71B2	0,55	0,75	2800	68,00	0,93	3,781	3,97	1,88	0,65	1,7	25	7,2	5,5	12
6... 71C2	0,75	1	2540	67,00	0,98	4,970	3,00	2,82	0,67	1,55	30	8,2	5,5	12
6... 80A2	0,75	1	2810	69,00	0,94	5,028	3,98	2,55	0,65	1,7	30	9,6	11	16
6... 80B2	1,1	1,5	2820	70,00	0,94	7,268	3,85	3,73	0,65	1,7	40	11	11	16
6... 80C2	1,84	2,5	2710	62,50	0,99	12,900	3,00	6,48	0,75	1,67	55	13,1	11	16
6... 90S2	1,5	2	2820	71,00	0,94	9,772	4,09	5,08	0,65	1,8	50	14	12	20
6... 90L2	2,2	3	2820	74,00	0,94	13,751	4,36	7,45	0,65	1,8	60	16,5	12	20
6... 100L2	3	4	2840	75,00	0,94	18,501	4,05	10,09	0,6	1,8	90	25	21	40

4 POLI / 4 POLES 6MS 6MK 1500rpm condensator de functionare / run capacitor														
Type	kW	HP	rpm	$\eta\%$	cos ϕ	I_n	I_s/I_n	C_n	C_s/C_n	C_{max}/C_n	Run Cap. (μ F)	kg	Cf Brake torque Nm 6MS	Cf Brake torque Nm 6MK
6... 63A4	0,12	0,16	1380	52,00	0,92	1,091	3,21	0,83	0,65	1,6	10	4	3,5	5
6... 63B4	0,18	0,25	1390	55,00	0,92	1,547	3,56	1,24	0,65	1,5	12	4,6	3,5	5
6... 63C4	0,25	0,34	1380	62,50	0,99	1,760	2,60	1,73	0,63	1,57	14	5,4	3,5	5
6... 71A4	0,25	0,34	1380	51,00	0,92	2,317	3,45	1,73	0,75	1,5	20	6,7	5,5	12
6... 71B4	0,37	0,5	1390	55,00	0,90	3,250	3,08	2,54	0,67	1,5	25	8,2	5,5	12
6... 71C4	0,55	0,75	1385	70,00	0,99	3,450	3,04	3,79	0,45	1,47	20	8,4	5,5	12
6... 80A4	0,55	0,75	1360	63,00	0,94	4,038	3,71	3,86	0,7	1,7	25	9,2	11	16
6... 80B4	0,75	1	1360	65,00	0,94	5,337	3,75	5,27	0,68	1,7	35	9	11	16
6... 80C4	0,9	1,2	1345	68,50	0,97	5,890	4,00	6,39	0,64	1,69	40	10,3	11	16
6... 90S4	1,1	1,5	1360	70,00	0,94	7,268	4,13	7,72	0,65	1,8	45	14,5	12	20
6... 90L4	1,5	2	1360	72,00	0,94	9,636	4,15	10,53	0,62	1,8	55	16,2	12	20
6... 90LA4	1,84	2,5	1360	76,00	0,99	10,600	4,00	12,92	0,69	1,8	70	19,1	12	20
6... 100LA4	1,84	2,5	1380	76,00	0,97	10,900	4,00	12,73	0,45	1,6	60	20	21	40
6... 100LB4	2,2	3	1400	68,00	0,90	15,629	3,84	15,01	0,67	1,8	110	24,5	21	40
6... 100LC4	3	4	1400	76,00	0,94	18,258	4,11	20,46	0,48	1,8	100	30	21	40

Datele tehnice si performantele se pot modifica / Technical data and performances may change



6.0 Sectiunea ATEX

ATEX section

Certificarea ATEX, acronimul ATmosphères EXplosibles, este obligatorie pentru toate produsele instalate in medii cu risc de explozie din statele membre ale Uniunii Europene.

ATEX certification, acronym of ATmosphères EXplosibles, is mandatory for all products installed in explosion risk environments in the Member States of the European Union.

Marcajul specific (Ex, fig. A) indica faptul ca aparatul electric este fabricat pentru a evita riscul de explozie in zone care pot fi supuse unei atmosfere potential explozive, definita de articolul 288 din Decretul legislativ italian 81/08, astfel cum a fost modificat prin Decretul legislativ italian 106/09, ca „un amestec cu aerul, in conditii atmosferice, de substante inflamabile in stare de gaz, vapori, ceturi sau prafuri in care, dupa aprindere, arderea se extinde la intregul amestec nears”. Cele trei elemente care pot induce o explozie sunt:

- ◆ *Agent combustiv*, oxigenul din aer
- ◆ *Substanta combustibila, gaz*, vapori sau *praf*. IPericolul cauzat de acesta din urma in ceea ce priveste gazele si vaporii este adesea subestimat, chiar daca este adesea mai devastator. Multe produse aparent inofensive, cum ar fi faina, zaharul, materialele plastice, lemnul, pesticidele si metalele, odata dispersate in aer sub forma de praf, pot provoca explozii care sunt cu atat mai violente cu cat particulele sunt mai mici. Prin urmare, explozia se poate propaga.
- ◆ *Sursa de aprindere*, cum ar fi, de exemplu, scantei generate mecanic, flacari sau puncte fierbinti, sarcini electrostatice, radiatii ionizante, aparate electrice etc.

Aparatele si sistemele de protectie ATEX sunt, prin urmare, destinate utilizarii in medii potential explozive, unde nivelurile de risc sunt determinate de Directiva Uniunii Europene 2014/34/UE, in vigoare de la 30 martie 2014, care abroga Directiva 94/9/CE din 20 aprilie 2016, transpusa in Italia prin Decretul Prezidential 126 din 23 martie 1998. Este responsabilitatea utilizatorului final al produsului sa comunice clasa de risc determinata sub propria sa responsabilitate, in conformitate cu Directiva Europeana 1999/92/CE, care indica **la ce temperatura pot apare inflamabilitatea si exploziile**. In acest sens, se va furniza un dispozitiv adecvat.

Standardele internationale IEC 61241-10 stabilesc criteriile pentru clasificarea zonelor periculoase in raport cu natura chimica, caracteristicile fizice si calitatea substantelor utilizate, pe baza frecventei si a perioadei de timp in care poate aparea un amestec exploziv. Criteriile pentru zonele cu risc de explozie din cauza pulberilor inflamabile, conductive sunt stabilite de EN 60079-10-2.

The specific mark (Ex, fig. A) indicates that the electric apparatus is manufactured to avoid the risk of explosion in areas that may be subject to a potentially explosive atmosphere, defined by Article 288 of Italian Legislative Decree 81/08, as amended by Italian Legislative Decree 106/09, as “a mixture with air, under atmospheric conditions, of flammable substances in the state of gas, vapours, mists or dusts in which, after ignition has occurred, combustion spreads to the entire unburned mixture”.

The three elements that can induce an explosion are:

- ◆ *Combustive agent*, the oxygen in the air
- ◆ *Combustible substance, gas, vapour or dust*. The danger caused by the latter with respect to the gases and vapours is often underestimated even though often more devastating. Many, apparently innocuous products, such as flour, sugar, plastics, wood, pesticides and metals, once dispersed in the air as dust may cause explosions which are more violent the smaller the particles. The explosion may, therefore, propagate.
- ◆ *Ignition source*, such as for example mechanically generated sparks, flames or hot points, electrostatic charges, ionizing radiation, electrical appliances, etc.

ATEX appliances and protection systems are, therefore, intended for use in potentially explosive environments, where the levels of risk are determined by the European Union Directive 2014/34/EU in force since 30 March 2014, repealing Directive 94/9/EC from 20 April 2016, transposed in Italy with Presidential Decree 126 of 23 March 1998.

*It is the responsibility of the end user of the product to communicate the risk class determined under his own responsibility, in accordance with European Directive 1999/92/EC, which indicates **at what temperature flammability and explosions may occur**. In virtue of this, a suitable device will be supplied.*

The international standards IEC 61241-10 lay down the criteria for the classification of hazardous areas in relation to the chemical nature, the physical characteristics and quality of the substances used, based on the frequency and the period of time in which an explosive mixture may occur. The criteria for areas with risk of explosion due to flammable, conductive dusts are laid down by EN 60079-10-2.

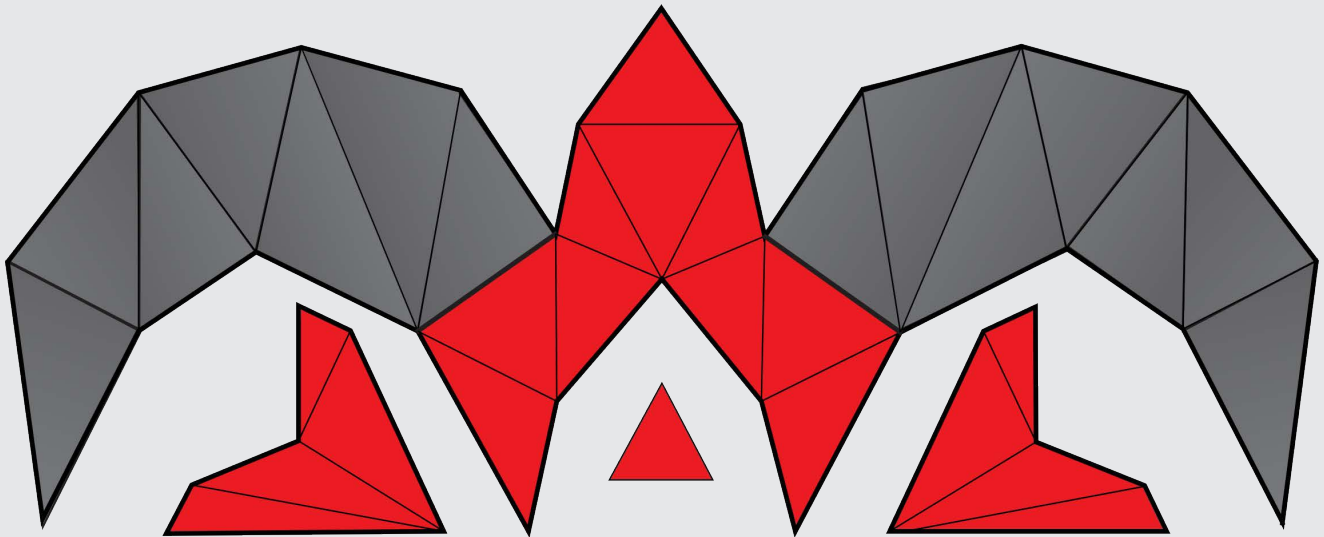

ALL INDUSTRIAL

Directiva Europeana 1999/92/CE reglementeaza clasificarea zonelor cu risc de explozie, conform urmatoarelor prevederi:

Pentru clasificarea zonelor, puteti consulta standardele tehnice armonizate referitoare la sectoare specifice, inclusiv:

- ◆ EN 60079-10 (IEC 60079-10) Aparatura electrica pentru atmosfere explozive de gaze. Partea 10: Clasificarea locurilor periculoase.
- ◆ EN 60079-10-2 Atmosfere explozive
- ◆ Partea 10-2: Clasificarea locurilor - Atmosfere explozive in prezenta prafului combustibil.

Zona 0

Un loc in care o atmosfera exploziva constand dintr-un amestec cu aer de substante periculoase sub forma de gaz, vapori sau ceata este prezenta continuu sau pentru perioade lungi de timp sau frecvent.

NOTA: In general, aceste conditii, atunci cand sunt prezente, afecteaza interiorul rezervoarelor, tevilor si recipientelor etc.

Zona 1

Un loc in care, in timpul functionarii normale, este probabil sa apara ocazional o atmosfera exploziva constand dintr-un amestec cu aer de substante periculoase sub forma de gaz, vapori sau ceata.

NOTA: Aceasta zona poate include, printre altele:

- zone in imediata vecinatate a zonei 0;
- zone in imediata vecinatate a deschiderilor de alimentare;
- zone in imediata vecinatate a deschiderilor de umplere si golire;
- zone in imediata vecinatate a dispozitivelor, sistemelor de protectie si componentelor fragile din sticla, ceramica si materiale similare;
- zone in imediata vecinatate a garniturilor de etansare inadecvata, de exemplu, la pompe si valve cu garnituri de etansare.

The European Directive 1999/92/EC governs the classification of areas at risk of explosion, according to these provisions:

For the classification of areas, you can refer to the harmonised technical standards relating to specific sectors, including:

- ◆ EN 60079-10 (IEC 60079-10) Electrical apparatus for explosive gas atmospheres. Part 10: Classification of hazardous places.
- ◆ EN 60079-10-2 Explosive atmospheres
- ◆ Part 10-2: Classification of places - Explosive atmospheres in the presence of combustible dust.

Zone 0

A place in which an explosive atmosphere consisting of a mixture with air of dangerous substances in the form of gas, vapour or mist is present continuously or for long periods or frequently.

NOTE: In general, these conditions when present, affect the inside of tanks, pipes and containers, etc.

Zone 1

A place in which an explosive atmosphere consisting of a mixture with air of dangerous substances in the form of gas, vapour or mist is likely to occur in normal operation occasionally.

NOTE: This zone may include, among others:

- areas in the immediate vicinity of zone 0;
- areas in the immediate vicinity of feed openings;
- areas in the immediate vicinity of filling and emptying openings;
- areas in the immediate vicinity of devices, protection systems and fragile components in glass, ceramic and similar materials;
- areas in the immediate vicinity of inadequately sealed glands, e.g. on pumps and valves with glands.

Zona 2

Un loc in care este putin probabil sa apara in timpul functionarii normale o atmosfera exploziva constand dintr-un amestec de substante periculoase sub forma de gaz, vapori sau ceata cu aer, dar, daca apare, va persista doar pentru o perioada scurta de timp.

Nota: Aceasta zona poate include, printre altele, locurile din jurul zonelor 0 sau 1.

Zona 20

Un loc in care o atmosfera exploziva sub forma unui nor de praf combustibil in aer este prezenta in mod continuu, pentru perioade lungi de timp sau frecvent.

Nota: In general, aceste conditii, atunci cand sunt prezente, afecteaza interiorul rezervoarelor, conductelor si recipientelor etc.

Zona 21

Un loc in care, in timpul functionarii normale, este probabil sa apara ocazional o atmosfera exploziva sub forma unui nor de praf combustibil in aer.

Nota: Aceasta zona poate include, de exemplu, printre altele, locuri in imediata vecinatate a punctelor de incarcare si descarcare a prafurilor si locuri in care se formeaza straturi de praf sau care, in timpul functionarii normale, ar putea produce o concentratie exploziva de prafuri combustibile amestecate cu aerul.

Zona 22

Un loc in care este putin probabil sa apara o atmosfera exploziva sub forma de nor de praf combustibil in aer in timpul functionarii normale, dar, daca apare, va persista doar pentru o perioada scurta de timp.

Nota: Aceasta zona poate include, printre altele, locuri din vecinatatea echipamentelor, sistemelor de protectie si componentelor care contin prafuri din care acestea se pot elibera din cauza pierderii si formarii depunerilor de praf (de exemplu, sare macinata in care praful se scurge din mori si se depune).

Nota:

1. Straturile, depunerile sau acumularile de praf combustibil sunt considerate orice alta sursa care poate forma o atmosfera exploziva.
2. „Activitate normala” inseamna o situatie in care instalatiile sunt utilizate in limitele parametrilor lor de proiectare.

Clase de temperatura pentru atmosfere gazoase

Exista sase clase care clasifica echipamentele electrice in functie de temperatura maxima atinsa in timpul functionarii in conditii normale in orice punct al suprafetei lor.

Zona 2

A place in which an explosive atmosphere consisting of a mixture with air of dangerous substances in the form of gas, vapour or mist is not likely to occur in normal operation but, if it does occur, will persist for a short period only.

NOTE: This zone may include, among others, place surrounding zones 0 or 1.

Zona 20

A place in which an explosive atmosphere in the form of a cloud of combustible dust in air is present continuously, or for long periods or frequently.

NOTE: In general, these conditions when present, affect the inside of tanks, pipes and containers, etc.

Zona 21

A place in which an explosive atmosphere in the form of a cloud of combustible dust in air is likely to occur in normal operation occasionally.

NOTE: This zone may include, for example, among others, places in the immediate vicinity of loading and unloading points of dusts and places in which layers of dust are formed, or which, during normal operation, could produce an explosive concentration of combustible dusts mixed with the air.

Zona 22

A place in which an explosive atmosphere in the form or a cloud of combustible dust in air is not likely to occur in normal operation but, if it does occur, will persist for a short period only.

NOTE: This zone may include, among others, places in the vicinity of equipment, protective systems and components containing dusts from which the dusts may escape due to the loss of and formation of dust deposits (e.g. Ground salt in which the dust escapes from mills and is deposited).

NOTE:

1. Layers, deposits or accumulations of combustible dust are considered as any other source which can form an explosive atmosphere.
2. “Normal activity” means a situation in which the installations are used within their design parameters.

Temperature classes for gas atmospheres

There are six classes that classify electrical equipment according to the highest temperature reached during operation under normal conditions in any point of their surface.

Temperatura de aprindere a amestecului exploziv (°C) <i>Ignition temperature of the explosive mixture (°C)</i>	Clasa de temperatura <i>Temperature class</i>	Temperatura maxima a suprafetei echipamentului electric la o temperatura ambianta de 40°C <i>Maximum surface temperature of the electrical equipment with an ambient temperature of 40°C</i>	
		°C	F
peste 450 / <i>over 450</i>	T1	450	842
de la 300 pana la 450 / <i>from 300 to 450</i>	T2	300	572
de la 200 pana la 300 / <i>from 200 to 300</i>	T3	200	392
de la 135 pana la 200 / <i>from 135 to 200</i>	T4	135	275
de la 100 pana la 135 / <i>from 100 to 135</i>	T5	100	212
de la 85 pana la 100 / <i>from 85 to 100</i>	T6	85	185

(tab. 38)

Utilizatorul trebuie sa se asigure ca sistemul electric care alimenteaza motorul a fost pozitionat corect si in siguranta in ceea ce priveste riscul de explozie si ca a fost intocmit un document privind protectia impotriva exploziilor.

Marcarea motoarelor si a altor echipamente electrice cu simboluri care indica modul de protectie, grupa de explozie si clasa de temperatura indica zona in care poate fi instalat produsul. Responsabilitatea alegerii echipamentului adecvat revine utilizatorului. Partea electrica a motoarelor aLLIndustrial a fost construita in conformitate cu Directiva 2006/95/CE (joasa tensiune) si Directiva 2004/108/CE (EMC).

The user must make sure that the electrical system that supplies the motor has been properly and safely positioned with regards to risk of explosion and that a document on protection against explosions has been drafted.

The marking of motors and other electrical equipment with symbols indicating the protection mode, the explosion group and temperature class indicates the area where the product can be installed.

The responsibility of choosing suitable equipment is borne by the user. The electrical part of the aLLIndustrial motors has been built in compliance with Directive 2006/95/EC (low voltage) and Directive 2004/108/EC (EMC).

Moduri de protectie electrica

Directiva Europeana clasifica modurile de protectie in diferite tipuri, dintre care cele mai importante sunt urmatoarele:

1. Mod de protectie „d” impotriva exploziilor.
Acest tip este o protectie pentru limitarea exploziilor.
2. Mod de protectie „e” prin siguranta sporita.
Metoda de siguranta bazata in esenta pe supradimensionarea materialelor izolatoare si a pieselor electrice.
3. Mod de protectie „m” prin incapsulare. Metoda de siguranta bazata pe incapsularea constructiilor in blocuri de rasina (incapsulare), prevenind contactul cu atmosfera periculoasa.
4. Mod de protectie „p” prin suprapresiune Metoda de siguranta bazata pe suprapresiune interna. In acest caz, exista o compensare continua a gazului de protectie. Daca carcasele nu sunt etanse, exista suprapresiune cu compensarea pierderilor.
5. Mod de protectie „q” prin umplere cu pulbere. Metoda de siguranta bazata pe stingerea flacarilor folosind material de umplere (nisipul este foarte comun).
6. Metoda de protectie „o” prin imersie in ulei. Metoda bazata pe aprindere fara flacara, deoarece este imersata in ulei.
7. Metoda de protectie „nA” pentru echipamente electrice fara scantei, cum ar fi masini rotative, sigurante, baterii.

Electrical protection modes

The European Directive classifies protection modes into various types, the most important of which are the following:

1. Protection mode “d” against explosions.
This type is a protection to contain explosions.
2. Protection mode “e” by increased safety.
Safety method based substantially on the oversizing of the insulating materials and electrical parts
3. Protection mode “m” by encapsulation. *Safety method based on enclosing constructions in blocks of resin (encapsulation), preventing contact with the dangerous atmosphere.*
4. Protection mode “p” by overpressure *Safety method based on internal overpressure. In this case, there is a continuous compensation of the shielding gas. If the cases are not sealed, there is overpressure with compensation of losses.*
5. Protection mode “q” by powder filling. *Safety method based on the extinction of flames using filling material (sand is very common).*
6. Protection method “o” by oil immersion. *Method based on non-flame ignition because it is immersed in oil.*
7. Protection method “nA” for non-sparking electrical equipment, such as rotating machinery, fuses, batteries.

aLlindustrialL adapteaza motoarele electrice la cele mai extreme conditii meteorologice si la cele mai periculoase locuri de munca, datorita investitiilor continue in tehnologie si a unei cunoasteri aprofundate a cerintelor clientilor.

aLlindustrialL adapts electric motors to the most extreme weather conditions and the most hazardous workplaces, thanks to ongoing investments in technology and an in-depth knowledge of customer requirements.



7.0 Modele speciale de motoare electrice

Special designs

Cod Code	Optiune	Option	
Protectie electrica / Electrical protection			7.1
CLH	Clasa de izolatie H pentru temperaturi ridicate	Insulation class H for high temperatures	7.1.1
TROP	Tropicalizare	Tropicalisation	7.1.2
SAC	Rezistente anticondens	Anti-condensation heaters	7.1.3
KLI	Dispozitiv cu termistor bimetalic Klixon	Klixon bimetallic thermistor device	7.1.4
PTC	Termistoare PTC	PTC thermistors	7.1.5
PT100A	Termometru de rezistenta PT100 pentru infasurare	PT100 resistance thermometer for winding	7.1.6
PT100	Termometru de rezistenta PT100 pentru rulmenti	PT100 resistance thermometer for bearings	7.1.7
Protectie fizica / Physical protection			7.2
IP56	Protectie IP 56	IP 56 protection	7.2.1
IP65	Protectie IP 65	IP 65 protection	7.2.2
IP66	Protectie IP 66	IP 66 protection	7.2.3
INC	Motor incapsulat	Encapsulated motor	7.2.4
FSC	Orificii de scurgere a condensului	Condensation drainage holes	7.2.5
TAP	Capac de ploaie	Rain cover	7.2.6
C5M	Acoperire pentru medii extrem de corozive	Coating for highly corrosive environments	7.2.7
Optiuni de asamblare / Assembly options			7.3
SC	Scut spate inchis	Closed back endshield	7.3.1
VA	Ventilator de racire din aluminiu	Aluminium cooling fan	7.3.2
BL - BLS	Cutie de borne laterala	Side terminal box	7.3.3
BP	Cutie de borne pe partea din spate	Terminal box on rear side	7.3.4
CU	Cabluri fara cutie de borne	Cables without terminal box	7.3.5
BIS	Arbore cu doua capete	Double ended shaft	7.3.6
AD	Arbore cu design special	Special design shaft	7.3.7
HEX	Cablu hexagonal pe partea din spate	NDE side Hexagonal socket	7.3.8
B5Q	Flansa patrata B5	Square B5 flange	7.3.9
NU	Rulment cilindric pe partea din fata	Cylindrical roller bearing on DE side	7.3.10
VER	Rulmenti pentru montare verticala	Bearings for vertical mounting	7.3.11
CIE	Rulmenti izolati electric	Electrically insulated bearings	7.3.12
CAT/CBT	Rulmenti pentru temperaturi ridicate/scazute	High/low temperature bearings	7.3.13
ANR	Opritor de mers inapoi	Backstop	7.3.14
VIB	Senzor de vibratii	Vibration sensor	7.3.15
LUB	Lubrificator automat	Automatic lubricator	7.3.16
Certificari / Certifications			7.4
ATEX	Certificare ATEX	ATEX certification	7.4.1
ULCSA	Conformitate UL-CSA	UL-CSA Conformity	7.4.2
GOST	Conformitate Gost - EAC - TRCU	Gost - EAC - TRCU Conformity	7.4.3
Optiuni de asamblare a franelor / Brake assembly options			7.5
FRX	Frana certificata ATEX	ATEX certified brake	7.5.1
FD	Alimentare directa a franei	Brake direct power supply	7.5.2
TSF	Tensiune speciala pentru frana	Special voltage for brake	7.5.3
RR	Redresor rapid pentru frana de curent continuu	Fast rectifier for DC brake	7.5.4
LSB	Maneta de eliberare manuala pentru frana	Hand release lever for brake	7.5.5
MIC	Microinterruptor pentru frana	Microswitch for brake	7.5.6
PGF	Garnitura de cauciuc pentru frana	Rubber brake seal	7.5.7
CPF	Capac de protectie a franei	Brake protection cap	7.5.8
Alte optiuni / Other options			7.6
AVP	Volanta cu pornire lina	Soft-start flywheel	7.6.1
CAE	Condensator electronic auxiliar	Auxiliary electronic capacitor	7.6.2
AVS	Infasurare simetrica pentru motor monofazat	Symmetrical winding for single-phase motor	7.6.3
INV	Motoinvertor	Motoinverter	7.6.4
ENC	Encoder	Encoder	7.6.5
SV	Racire forzata IC416 IP55	Forced cooling IC416 IP55	7.6.6

◆ 7.1 Protecție electrică / *Electrical protection*

7.1.1 CLH *Izolatie clasa H pentru temperaturi ridicate*

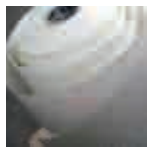

Infășurare statorică pentru funcționare la temperaturi ambientale peste 40°C; trebuie identificată temperatura ambientală maximă pentru a detecta orice ajustări necesare pentru funcționarea corectă a motorului.

Class H insulation for high temperature

Stator winding for operation at ambient temperatures over 40°C; the maximum ambient temperature must be identified to detect any adjustments required for correct motor operation.

7.1.2 TROP *Tropicalizare*



Protecție suplimentară a înfășurărilor statorice pentru utilizare în medii deosebit de umede și expuse la fluctuații termice puternice. Garantează o rezistență mai mare la umiditate și face ca bobinele de înfășurare să fie hidrofuge.

Tropicalisation

Added stator winding protection for use in environments that are particularly humid and exposed to strong thermal excursions. It guarantees greater resistance to humidity and makes the winding coils water repellent.

7.1.3 SAC *Incalzitoare anticondens*



Motoarele care funcționează în medii foarte umede (RH > 60%) sau reci (T < -20°C) pot fi echipate cu o rezistență anticondens pentru a fi utilizate atunci când motorul este oprit. Elementul de încălzire înfășoară bobinele de înfășurare; alimentarea monofazată de 230V50Hz este furnizată de conectorii auxiliari situați în interiorul cutiei de borne a motorului principal.

Anti-condensation heaters

Motors operating in very humid (RH > 60%) or cold environments (T < -20°C) can be fitted with an anti-condensation heater to use when the motor is switched off. The heating element wraps around the winding coils; the single-phase power supply 230V50Hz is supplied by the auxiliary connectors located inside the terminal box of the main motor.

Putere incalzitor anticondens / *Anti-condensation heater power*

MEC	56	63	71	80	90	100	112	132	160	180	200	225	250	280	315	355
Watt 230V50-60Hz	8	8	8	25	25	25	25	40	40	26	26	42	42	42	65	99

(tab. 41)

7.1.4 KLI *Termistoare bimetalice Klixon*



Protecții termice instalate pe înfășurare, constând dintr-un disc bimetalic care, atunci când se atinge temperatura nominală de comutare (NST = 135°C), comută de la contact normal închis (NC) la contact deschis. Pe măsură ce temperatura scade, contactul revine în poziția de repaus (NC). Sonde termice bimetalice cu o temperatură de comutare diferită sau sonde termice bimetalice normal deschise (NO) sunt disponibile la cerere.

Klixon bimetallic thermistors

Thermal protectors installed on the winding consisting of a bimetallic disc that, when the nominal switching temperature (NST = 135°C) is reached, switches from normally closed contact (NC) to open contact. As the temperature drops, the contact returns to the idle position (NC). Bimetallic thermal probes with a different switching temperature or normally open (NO) bimetallic thermal probes are available on request.

7.1.5 PTC *Termistoare PTC*



PTC-urile (termistoare cu coeficient de temperatura pozitiv) sunt semiconductori care prezinta o schimbare rapida a rezistentei atunci cand se atinge temperatura nominala de comutare, de obicei 150°C (la cerere, se pot furniza PTC-uri de la 90 la 160°C). Acesti senzori, care sunt instalati pe infasurare, sunt foarte compacti, au un raspuns foarte rapid si practic nu prezinta uzura. Acestia sunt utilizati de obicei pentru controlul alarmelor, iar alimentarea recomandata este intre 2,5 - 7,5Vcc. Rezistenta cu motorul oprit sau in timpul functionarii normale este de aproximativ 80 ohmi. In cazul supraincalzirii infasurarii, aceasta creste rapid peste 1000 ohmi.

Spre deosebire de sondele bimetalice (Klixon), PTC-urile nu pot controla direct relelele si, prin urmare, trebuie conectate la un dispozitiv de declansare adecvat.

Terminalele sunt situate intr-o clema flotanta in interiorul cutiei de borne a motorului.

PTC thermistors

PTCs (positive temperature coefficient thermistor) are semiconductors that exhibit a rapid resistance change when the nominal switching temperature, usually 150°C, is reached (on request, PTCs from 90 to 160°C can be supplied). These sensors, which are installed on the winding, are very compact, have a very fast response and are practically free from wear. They are typically used to control alarms and the recommended power supply is between 2.5 - 7.5Vcc. The resistance with the motor switched off or during the normal operation is around 80 ohms. In the event of overtemperature of the winding, this quickly rises above 1000 ohms.

Unlike the bimetallic probes (Klixon), PTCs cannot directly control the relays and must, therefore, be connected to a suitable release device.

The terminals are located in a floating clamp inside the terminal box of the motor.

7.1.6 PT100A *Termometru de rezistenta pentru infasurare*



Rezistenta de platina cu variatie liniara pe masura ce temperatura infasurarii creste. Este ideala daca trebuie sa verificati constant variatiile de temperatura si (spre deosebire de PTC), PT100 trimite si un semnal chiar daca firele sunt deosebit de lungi.

Resistance thermometer for winding

Platinum resistance with linear variation as the winding temperature increases. It is ideal if you need to constantly check the temperature variations and (unlike the PTC), the PT100 also sends a signal even if the wiring is particularly long.

7.1.7 PT100 *Termometru de rezistenta pentru rulmenti*



Rezistenta de platina cu variatie liniara pe masura ce temperatura rulmentului creste, deoarece este instalata langa rulmenti. Trimite un semnal chiar daca firele sunt deosebit de lungi. Poate fi furnizata de la MEC200 in sus.

Resistance thermometer for bearings

Platinum resistance with linear variation as the bearing temperature increases since it is installed near the bearings. It sends a signal even if the wiring is particularly long. Can be supplied from MEC200 upwards.

◆ 7.2 Protecție fizică / *Physical protection*

7.2.1 IP56/65/66

Indicele de protecție

Protection Index

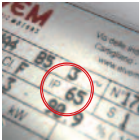
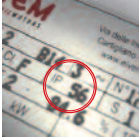

Nivelul de protecție împotriva corpurilor străine solide și lichide pentru echipamentele electrice este clasificat conform standardului IP (indicele de protecție). Nivelul standard pentru motoare este **IP55** (protecție împotriva prafului și jeturilor de apă din toate direcțiile). La cerere, este posibil să se obțină:

- protecție **IP56** (protejat împotriva prafului și jeturilor de apă sub presiune din toate direcțiile);
- protecție **IP65** (fără pătrunderea prafului, protejat împotriva jeturilor de apă din toate direcțiile);
- protecție **IP66** (fără pătrunderea prafului, protejat împotriva jeturilor de apă sub presiune din toate direcțiile);

*The level of protection from solid and liquid foreign bodies for electrical equipment is classified according to the IP standard (index of protection). The standard level for motors is **IP55** (protection against dust and jets of water from all directions). On request, it is possible to obtain:*

- **IP56** protection (protected against dust and water jets under pressure from all directions);
- **IP65** protection (no dust ingress, protected against water jets from all directions);
- **IP66** protection (no dust ingress, protected against water jets under pressure from all directions);

7.2.4 INC

Motor capsulat

Encapsulated motor



În condiții specifice de utilizare, este necesară protejarea completă a statorului și a tuturor componentelor motorului prin izolarea lor electrică cu o rășină specială care umple spațiile goale din interiorul motorului. Înfășurarea este apoi complet protejată de apă sau lichide.

In specific conditions of use, it is necessary to fully protect the stator and all the motor components by insulating them electrically with a special resin that fills the empty spaces inside the motor. The winding is then fully protected from water or liquids.

7.2.5 FSC

Gauri de scurgere

Condensation drainage holes

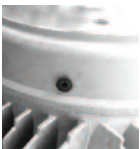

Dacă motorul este utilizat în medii foarte umede sau unde există o fluctuație termică puternică, este posibil să se găsească o gaură în carcasa motorului pentru a facilita scurgerea condensului. Pentru a găsi gaurile în cel mai bun loc, trebuie să știți unde va fi poziționat motorul.

If the motor is used in very damp environments or where there is a strong thermal excursion, it is possible to drill a hole in the motor casing to facilitate condensation drainage. To drill the holes in the best place, you need to know where the motor will be positioned.

7.2.6 TAP

Husa de ploaie

Rain cover



Pentru instalarea în exterior, în poziție verticală, cu axul în jos, se recomandă montarea unui capac metalic de protecție pe capacul ventilatorului.

For installation outside in a vertical position with the shaft facing downwards, it is advisable to mount a protective metal cover on the fan cover.

7.2.7 C5M

Acoperire pentru medii extrem de corozive



Finisaj de suprafata conceput pentru utilizare in medii clasificate C5M conform ISO 12994 (vopsea marina). Ciclul de acoperire consta in:

1. Indepartarea grasimii si uleiului
2. Asperarea suprafetei prin sablare de tip SA 2.5
3. Grund epoxidic bogat in zinc, cu un continut ridicat de zinc
4. Strat intermediar epoxidic bicomponent
5. Strat emailat poliuretanic acrilic bicomponent

Coating for highly corrosive environments

Surface finish designed for use in C5M classified environments according to ISO 12994 (marine paint).

The coating cycle consists of:

1. *Removal of grease and oil*
2. *Roughening of the surface by type SA 2.5 sandblasting*
3. *Zinc-rich, epoxy primer with a high zinc content*
4. *Two-component epoxy intermediate coating*
5. *Two-component, acrylic, polyurethane enamel coating*

◆ 7.3 Optiuni de montare / Mounting options

7.3.1 SC

Scut frontal inchis (IC 418)



La cerere, motorul poate fi furnizat fara ventilator de racire, cu flaconul posterior inchis. Racirea trebuie insa garantata de fluxul de aer din jur sau tipul de serviciu trebuie sa prevada cicluri de repaus suficient de lungi pentru a permite motorului sa se raceasca.

Closed back endshield (IC 418)

On request, the motor can be supplied without a cooling fan, with the back endshield closed. Cooling, however, must be guaranteed by the surrounding airflow or the type of service must provide rest cycles that are long enough to allow the motor to cool.

7.3.2 VA

Ventilator de racire din aluminiu



Pentru utilizare la temperaturi ambientale ridicate, este posibila montarea unui ventilator de racire din aluminiu in loc de unul din rasina termoplastica.

Aluminium cooling fan

For use in high ambient temperatures, it is possible to mount an aluminium cooling fan instead of one in thermoplastic resin.

7.3.3BL/BLS

Cutie de borne laterala



Cutie de borne laterala pentru B3. Pentru pozitia de montare B3, cutia de borne este plasata implicit cu fata in sus. Poate fi plasata lateral la cerere. Aceasta optiune este disponibila in versiunea BLS pentru motoarele din fonta cu picioare fixe.



Side terminal box

Side terminal box for B3. For B3 mounting position, the terminal box is placed by default facing upwards. It can be placed on the side on request. This option is available in the BLS version for cast iron motors with fixed feet.

7.3.4 BP

Cutie de borne pe partea din spate

Terminal box on rear side



In unele cazuri, cutia de borne trebuie montata pe partea din spate, langa capota ventilatorului. Poate fi furnizata la cerere pentru majoritatea motoarelor. Va rugam sa consultati aLLindustrial pentru a verifica fezabilitatea.

In some cases, the terminal box must be mounted on the rear side, near the fan hood. It can be supplied on request for most motors. Please consult aLLindustrial refer to check feasibility.

7.3.5 CU

Cabluri fara cutie de borne

Cables without terminal box



Aceasta optiune va permite sa reducati dimensiunea radiala a motorului si sa accelerati operatiunile de cablare. Poate fi furnizata la cerere pentru toate motoarele standard cu polaritate simpla si dubla. Cutia de borne a fost complet indepartata.

This option allows you to decrease the radial size of the motor and speed up wiring operations. It can be supplied on request for all standard single and double polarity motors. The terminal box has been completely removed.

7.3.6 BIS

Arbore cu doua capete

Double ended shaft



Al doilea capat al arborelui este realizat prin extinderea arborelui pe partea din spate (NDE). Trebuie sa specificati diametrul, lungimea si dimensiunile cheii. Va rugam sa ne contactati pentru utilizare impreuna cu alte optiuni.

The second shaft end is made by extending the shaft on the NDE. You must specify the diameter, length and dimensions of the key. Please contact us for use in conjunction with other options.

7.3.7 AD

Arbore cu design special

Special design shaft



Pentru aplicatii specifice, putem furniza motoare cu arbori realizati conform unui design specific al clientului. Trebuie sa specificati diametrul, lungimea, dimensiunea si pozitia cheii.

For specific applications, we can supply motors with shafts made to a specific customer design. You must specify the diameter, length, size and position of the key.

7.3.8 HEX

Spate - Soclu hexagonal

NDE side Hexagonal socket



Daca trebuie sa rotiti manual arborele motorului, putem prelucra partea din spate prin introducerea unui soclu hexagonal pentru a-l manevra.

If you need to turn the motor shaft manually, we can work the NDE by inserting a hexagonal socket to manoeuvre it.

7.3.9 B5Q

Flansa patrata B5

Square B5 flange



Pentru aplicatii specifice, putem furniza motoare cu o flansa realizata conform designului clientului. Va rugam sa verificati fezabilitatea cu departamentul nostru tehnic dupa furnizarea desenului.

For specific applications, we can supply motors with a flange made to the customer's design. Please check the feasibility with our technical department after supplying the drawing.

7.3.10 NU *Rulment cilindric pe partea din fata*

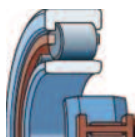

Daca exista sarcini radiale mari pe partea din fata a arborelui, se poate utiliza un rulment cilindric. Acesta este furnizat standard la motoarele cu 4, 6 si 8 poli de la MEC315 la MEC450.

Cylindrical roller bearing on DE side

If there are high radial loads on the DE of the shaft, a cylindrical roller bearing can be used. It is supplied standard on motors with 4, 6 and 8 poles from MEC315 to MEC450.

7.3.11 VER *Montare verticala*



Daca arborele este pozitionat vertical, de la o dimensiune de 280 in sus, recomandam utilizarea rulmentilor cu bile cu contact unghiular pentru a sustine sarcina axiala pe arbore. Trebuie acordata o atentie deosebita pozitionarii arborelui (in sus sau in jos) si localizarii pozitiei de montare pe baza tabelului „Configuratii si aranjamente de montare”. Motoarele cu rulmenti conici pot fi, de asemenea, furnizate la cerere.

Vertical Mounting

If the shaft is positioned vertically, from a size of 280 upwards, we recommend using angular contact ball bearings to support the axial load on the shaft. Great care should be taken over the positioning of the shaft (upwards or downwards) and locating the mounting position based on the table “Configurations and mounting arrangements”. Motors with tapered roller bearings can also be supplied on request.

7.3.12 CIE *Rulmenti izolati electric*

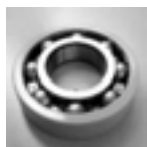

In motoarele electrice, actionate de inverter, se pot genera diferente de potential intre capetele arborelui care dezvolta curenti turbionari la frecventa inalta, potential daunatori pentru elementele de rulare si caile de rulare. Pentru a evita acest fenomen, aLLindustrial utilizeaza rulmenti izolati electric cu suprafete exterioare tratate cu oxid de aluminiu acoperit cu rasina. Rulmentii izolati pot fi rulmenti radiali cu bile, rulmenti cilindrici sau rulmenti axiali cu bile cu contact unghiular.

Electrically insulated bearings

In electric, inverter-driven motors, potential differences can be generated between the ends of the shaft that develop eddy currents at high frequency which are potentially harmful for the rolling elements and raceways. To avoid this phenomenon, aLLindustrial uses electrically insulated bearings with outer surfaces treated with resin-coated aluminium oxide. The insulated bearings can be radial ball bearings, cylindrical rollers or angular contact thrust ball bearings.

7.3.13 CAT/CBT *Rulmenti pentru temperaturi ridicate/scazute*



Pentru functionarea motorului la temperaturi extreme, recomandam utilizarea rulmentilor cu unsoari speciale pentru temperaturi ridicate (CAT - pentru temperatura ambianta mai mare de 50°C) sau temperaturi scazute (CBT - temperatura ambianta mai mica de -25°C).

Bearings for high/low temperatures

For motor operation at extreme temperatures, we recommend the use of bearings with special greases for high temperatures (CAT - for ambient temperature greater than 50°C) or low temperatures (CBT - ambient temperature lower than -25°C).

7.3.14 ANR *Opritor de mers inapoi*



Implementare care permite arborelui motorului sa se roteasca intr-o singura directie prin aplicarea unui opritor de mers inapoi: in directia libera, nu exista contact intre inelul interior si inelul exterior al opritorului de mers inapoi; in directia opusa, rotatia arborelui motorului este blocata de pene plasate intre cele doua inele. Aceasta aplicatie permite suportarea unor cupluri extrem de mari (chiar si peste 1000 Nm), dar viteza minima de rotatie nu trebuie sa fie mai mica de 600 rpm, excluzand etapele de pornire si oprire.

Backstop

Implementation that allows the motor shaft to rotate in a single direction by applying a backstop: in the free direction, there is no contact between the inner ring and the outer ring of the backstop; in the opposite direction, the rotation of the motor shaft is blocked by wedges which are placed between the two rings. This application means extremely high torques can be withstood (even over 1000Nm), but the minimum rotational speed must not be less than 600rpm, excluding the steps of starting and stopping.

7.3.15 VIB *Senzor de vibratii*



Traductoare utilizate pentru monitorizarea rulmentilor motoarelor electrice; analiza tipului de vibratie a rulmentilor permite detectarea defectiunilor legate de echilibrarea rotorului, lubrifiere sau uzura pieselor de rulare si transmiterea miscarii, permitand planificarea mai eficienta a interventiilor de intretinere.

Vibration sensor

Transducers that are used to monitor the bearings on electric motors; the analysis of the type of bearing vibration allows faults to be detected relating to balancing of the rotor, lubrication or wear of the rolling parts and transmission of motion, allowing you to plan maintenance interventions more efficiently.

7.3.16 LUB *Lubrificator automat*



Cartus sub presiune care se fixeaza in linie cu lubrifiatorii rulmentilor, pentru o lubrifiere constanta si controlata. Recomandat atunci cand motorul este instalat intr-o pozitie dificil accesibila pentru intretinere.

Automatic lubricator

Pressurized cartridge to be fixed in line with the bearings lubricators, for constant, controlled lubrication. Recommended when the motor is installed in a position that is difficult to access for maintenance.

◆ 7.4 Certificari / *Certification*

7.4.1 ATEX *Certificare ATEX*



Certificarea ATEX poate fi solicitata pentru motoarele destinate utilizarii in atmosfere potential explozive. Toate componentele utilizate (frana, racire forzata, encoder etc.) trebuie sa fie adecvate pentru utilizarea in zone cu risc ridicat mai mare sau egal cu cea in care va fi utilizat motorul (vezi sectiunea ATEX).

Certification ATEX

ATEX certification can be requested for motors intended for use in potentially explosive atmospheres. All the components used (brake, forced cooling, encoder, etc.) must be suitable for use in high-risk areas greater than or equal to that in which the motor will be used (see ATEX section).

7.4.2 ULCSA *Conformitate UL-CSA*



Declaratie de conformitate pentru pietele din SUA si Canada. Poate fi furnizata pentru majoritatea motoarelor noastre standard si cu frana. Nu poate fi emisa pentru motoare cu certificare ATEX si GOST. Motoarele cu reclamatie UL-CSA au un cod TM.

Conformity UL-CSA

Declaration of conformity for the USA and Canadian markets. It can be supplied for most of our standard and brake motors. It cannot be issued for motors with ATEX and GOST certification. UL-CSA complaint motors have a TM code.

7.4.3 GOST *Conformitate Gost – EAC-TRCU*



Declaratie de conformitate pentru uniunea vamala Rusia - Ucraina - Kazahstan; disponibila pentru toate motoarele noastre standard, cu frana si cu racire forzata. Nu poate fi emisa pentru motoarele cu certificare ATEX si pentru motoarele cu conformitate UL-CSA.

Conformity Gost - EAC - TRCU

Declaration of conformity for the customs union of Russia - Ukraine - Kazakhstan; available for all our standard, brake and forced cooling motors. It cannot be issued for motors with ATEX certification and for motors with UL-CSA conformity.

◆ 7.5 Optiuni de asamblare a franei / *Brake assembly options*

7.5.1 FRX

Frana certificata ATEX

ATEX certified brake



A se utiliza pe motoare cu frana pentru instalare in atmosfere potential explozive.

To be used on brake motors for installation in potentially explosive atmospheres.

7.5.2 FD

Alimentare directa a franei

Brake direct power supply



In unele aplicatii, este necesara alimentarea franei direct de la motor.

In some applications, it is necessary to power the brake directly from the motor.

7.5.3 TSF

Frana cu tensiune speciala

Special voltage brake



A se utiliza pe motoare cu frana care functioneaza la tensiuni diferite de cele standard de 230V50Hz sau 400V50Hz. Toleranta admisibila pentru tensiunea de franare AC este de 6%. Dincolo de aceasta limita, va rugam sa contactati aLLindustrial.

To be used on brake motors which operate at different voltages from the standard 230V50Hz or 400V50Hz. The allowable tolerance on the voltage for the AC brakes is 6%. Beyond this limit, please contact aLLindustrial.

7.5.4 RR

Redresor rapid pentru frana DC

Fast rectifier for DC brake



Acesta va permite sa accelerati raspunsul unui redresor de frana DC, injumatatind timpul de activare a electromagnetului.

It allows you to accelerate the response of a DC brake rectifier, halving the energising time of the electromagnet.

7.5.5 LSB

Parghie de eliberare a franei

Brake release lever



Dispozitiv care va permite sa eliberati manual placa de frana mobila a armaturii si, prin urmare, rotatia arborelui motorului.

Device which allows you to manually release the movable armature brake plate and therefore, the motor shaft rotation.

7.5.6 MIC *Microintrerupatoare pentru frana* *Micro switches for brake*



Comutator de semnalizare care detecteaza deschiderea si inchiderea franei.

Signal switch that detects the opening and closing of the brake.

7.5.7 PGF *Protectie din cauciuc-frana* *Rubber protection for brake*



Garnitura de cauciuc care protejeaza pista de frana de corpuri straine, mentinand eficienta si durata.

Rubber seal that protects the brake track from foreign bodies, maintaining efficiency and duration.

7.5.8 CPF *Capac de protectie a franei* *Brake protection cap*



Capac de protectie care acopera complet unitatea de frana pentru motoarele cu frana IP56. Disponibil pentru motoarele de tip K (CC) si C (CA). Nu este compatibil cu maneta de eliberare manuala si cu capacul de protectie.

Protective cap that completely covers the brake unit for IP56 brake motors. Available for type K (DC) and C (AC) motors. Not compatible with the manual release lever and with the protective cap.

◆ 7.6 Alte optiuni / Other options

7.6.1 AVP

Volanta cu pornire lina



Pentru a accelera treptat motorul, instalăm un ventilator din fonta care acționează ca o volanta motorizată, acumulând energie cinetică în timpul pornirii și eliberând-o în timpul frânării.

Soft-start flywheel

To gradually accelerate the motor, we install a cast iron fan which acts like a powered flywheel, accumulating kinetic energy during starting and releasing it during brake.

7.6.2 CAE

Condensator electronic auxiliar



Condensator electronic auxiliar Condensator auxiliar sau cuplu de pornire ridicat: la 1,5 secunde după pornirea motorului, acesta se deconectează automat prin intermediul unui întrerupător electronic încorporat. Nu este potrivit pentru aplicații cu timpi de pornire sub 1,5 secunde. Este necesar să așteptați 6 secunde între două porniri succesive.

Auxiliary electronic capacitor

Auxiliary electronic Capacitor Auxiliary capacitor or high starting torque: 1.5 seconds after starting the motor, it automatically disconnects by means of an in-built electronic circuit breaker. It is not suitable for applications with start times below 1.5 secs. It is necessary to wait 6 secs between two successive starts.

7.6.3 AVS

Infasurare simetrică pentru motoare monofazate



Tipul de înfasurare monofazată simetrică (numită și bifazată) utilizat atunci când este necesară inversarea sensului de rotație al motorului cu o cablare simplificată; funcționarea este mai liniară decât la un motor monofazat normal, dar cuplul de pornire este mai mic.

Symmetrical winding for single-phase motors

Type of single-phase winding symmetrical (also called bi/phase) used when it is necessary to reverse the direction of rotation of the motor with a simplified wiring; the operation is more linear than a normal single-phase motor, but the starting torque is smaller.

7.6.4 INV

Motoinverter



Fabricăm motoare cu invertoare cu control vectorial integrate la bord, complet programabile și cu PLC integrat, pentru alimentare monofazată de până la 1,1 kW și trifazată de până la 22 kW. Corpul invertoarelor este din aluminiu turnat sub presiune, iar protecția electrică este IP65 până la 7,5 kW inclusiv, IP55 pentru puteri mai mari. Opțiunea MOTOINVERTER poate fi însoțită de alte modele speciale (racire forțată, frână, encoder, tensiuni speciale etc.). Va rugăm să consultați documentația specifică și să contactați aLLindustrial pentru detalii.

Motoinverter

We manufacture motors with vector control inverters integrated on board, fully programmable and with integrated PLC, for single-phase power supply up to 1.1kW and three-phase up to 22kW. The inverter body is in die-cast aluminium and the electrical protection is IP65 up to 7.5 kW included, IP55 for higher power. The MOTOINVERTER option may be accompanied by other special designs (forced cooling, brake, encoder, special voltages, etc.). Please refer to the specific documentation and contact aLLindustrial for details.

7.6.5 ENC Encoder



La cerere, pe partea din spate a motorului se poate monta un encoder. Acesta este un dispozitiv de feedback care citește rotația arborelui și trimite un semnal (standard: 1024 impulsuri pe rotație, circuit universal PP/LD, tensiune de alimentare 5-30V, protecție IP65).



La cerere, sunt disponibile următoarele:

- Versiuni certificate ATEX 3GD și 2GD
- Versiuni IP67
- Rezoluții de la 100 la 204800 impulsuri pe rotație
- Diferite circuite de alimentare
- Conectori rapizi pentru cabluri
- După livrarea unei mostre, putem preconfigura instalarea pentru un encoder furnizat de client

Pentru dimensiunile de gabarit, consultați secțiunea dedicată („Dimensiuni ale modelelor speciale“)

Encoder

An encoder can be mounted on the rear side of the motor, on request. This is a feedback device that reads the shaft rotation and sends a signal (standard: 1024 pulses per revolution, universal circuit PP/LD, supply voltage 5-30V, IP65 protection).

On request, the following are available:

- ATEX 3GD and 2GD certified versions
- IP67 versions
- Resolutions from 100 to 204800 pulses per revolution
- Different power supply circuits
- Quick cable connectors
- After delivery of a sample, we can pre-configure installation for an encoder supplied by the customer

For overall dimensions, see the dedicated section (“Dimensions of special designs“).

7.6.6 SV Servoventilatie fortata IC416 IP55



Racire cu ventilator electric axial pentru actionari cu viteza variabila si/sau pentru cicluri grele, care asigura un schimb de caldura adecvat indiferent de rotatia motorului. Indicati „SV1” si „SV3” pentru a specifica alimentarea monofazata sau trifazata pentru racire fortata. De asemenea, disponibil cu protectie IP66 pentru motoare conform UL-CSA si pentru motoare cu certificare ATEX (de la MEC132 si peste, racirea fortata ATEX se realizeaza prin instalarea unui motor auxiliar ATEX pe capacul ventilatorului). Pentru aplicatii specifice, poate fi necesara utilizarea unei unitati compacte de racire fortata axiala (SV...R). Aceasta functioneaza ca o unitate standard de racire fortata, iar dimensiunea totala este similara cu cea a unui motor autoracit.

Forced cooling IC416 IP55

Cooling with axial electric fan for variable speed drives, and/or for heavy-duty cycles, which ensures adequate heat exchange regardless of the rotation of the motor. Indicate “SV1” and “SV3” to specify respectively the single or three-phase supply for forced cooling. Also available with IP66 protection for motors in accordance with UL-CSA and for motors with ATEX certification (from MEC132 and above, the ATEX forced cooling is achieved by installing an auxiliary ATEX motor on the fan cover). For specific applications, it may be necessary to use a compact axial forced cooling unit (SV...R). It works like a standard forced cooling unit and the overall size is like a self-cooled motor.

SV3 - IP55 Performante de racire fortata / Forced cooling performances

MEC MEC	Tensiune trifazata Voltage three phase	Intrare Input (W)	Curent Current (A)	rpm rpm	Capacitate Capacity (m ³ /h)	Presiune Pressure (Pa)	Zgomot Noise dB(A)
63	230/400V/50HZ	24	0,065	2800	45	40	62
71	230/400V/50HZ	25	0,065	2800	52	50	62
80	230/400V/50HZ	32	0,09	2900	58	60	62
90	230/400V/50HZ	32	0,09	2900	91	80	65
100	230/400V/50HZ	72	0,185	2750	142	80	67
112	230/400V/50HZ	85	0,175	2600	229	80	67
132	230/400V/50HZ	50	0,195	1450	337	35	69
160	230/400V/50HZ	60	0,2	1400	609	40	72
180	230/400V/50HZ	80	0,22	1350	686	55	72
200	230/400V/50HZ	110	0,23	1250	1679	65	72
225	230/400V/50HZ	80	0,29	1450	1786	70	74
250	230/400V/50HZ	115	0,45	1400	1813	80	75
280	230/400V/50HZ	200	0,5	1350	2415	85	78
315	230/400V/50HZ	555	1,02	1350	2820	110	81
355	230/400V/50HZ	420	0,96	900	3500	80	85

(tab. 42)

SV1 - IP55 Performante de racire fortata / *Forced cooling performances*

MEC MEC	Tensiune monofazata Voltage single phase	Intrare Input (W)	Curent Current (A)	rpm rpm	Capacitate Capacity (m ³ /h)	Presiune Pressure (Pa)	Zgomot Noise dB(A)
63	230V/50HZ	17	0.12	2800	45	40	62
71	230V/50HZ	18	0.13	2800	52	50	62
80	230V/50HZ	19	0.15	2800	58	60	62
90	230V/50HZ	20	0.14	2800	91	80	65
100	230V/50HZ	55	0.3	2700	142	80	67
112	230V/50HZ	65	0.37	2400	229	80	67
132	230V/50HZ	55	0.35	1400	337	35	69

(tab. 43)

SV36 - IP66 Performantele kitului de racire fortata / *Forced cooling kit performances*

MEC MEC	Tensiune trifazata Voltage three phase	Intrare Input (W)	Curent Current (A) 400V	rpm rpm	Capacitate Capacity (m ³ /h)	Presiune Pressure (Pa)	Zgomot Noise dB(A)
63	230/400V/50HZ	25	0.1	2900	45	40	62
71	230/400V/50HZ	30	0.1	2900	52	50	62
80	230/400V/50HZ	40	0.1	2900	58	60	62
90	230/400V/50HZ	40	0.11	2900	91	80	65
100	230/400V/50HZ	45	0.11	2850	142	80	67
112	230/400V/50HZ	50	0.11	2800	229	80	67
132	230/400V/50HZ	50	0.25	1450	337	35	69
160	230/400V/50HZ	60	0.25	1450	609	40	72
180	230/400V/50HZ	85	0.25	1450	686	55	72
200	230/400V/50HZ	125	0.3	1400	1679	65	72
225	230/400V/50HZ	140	0.37	1450	1786	70	74
250	230/400V/50HZ	260	0.72	1400	1813	80	75
280	230/400V/50HZ	270	0.75	1400	2415	85	78
315	230/400V/50HZ	450	1.70/0.98	1400	2820	110	81
355	230/400V/50HZ	650	2.20/1.27	1400	3500	80	85

(tab. 44)

8. Date dimensionale ale motorului

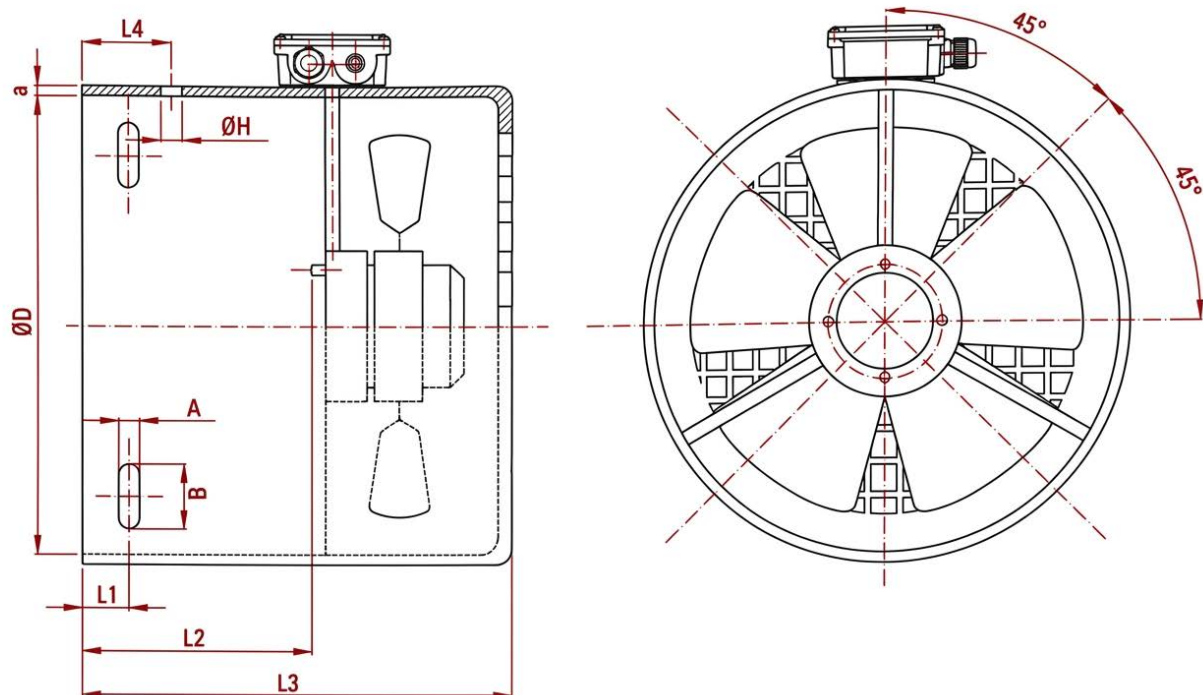

TIPO / TYPE	SERIE	ØD (mm)	L1 (mm)	L2 (mm)	L3 (mm)	L4 (mm)	ØH (mm)	a (mm)	A (mm)	B (mm)
SV3-63 / SV1-63	6...	121	8	69,5	157	-	-	1,2	6	12
SV3-71 / SV1-71	6...	137	7	79	167	-	-	1,3	6	12
SV3-80 / SV1-80	6...	156	8	96,5	183	-	-	1,7	6	12
SV3-90 / SV1-80	6...	175	8	106,5	192	-	-	1,5	6	12
SV3-100 / SV1-100	6...	197	10	102	198	-	-	1,5	6	12
SV3-112 / SV1-112	6...	218	9	107	203	-	-	1,5	6	12
SV3-132 / SV1-132	6...	260	10	125	229	-	-	1,5	6	12
SV3-160	7...	313	14	167	281	51	20	2	7	14
SV3-180	7...	352	26	192	311	57	20	2	7	14
SV3-200	7...	394	33	191	313	63	20	2	7	14
SV3-225	7...	443	32	221	374	63	20	2	7	14
SV3-250	7...	443	36	221	374	74	20	2	10	18
SV3-280	7...	550	38	242	429	99	20	2	10	18
SV3-315	7...	614	81	310	505	115	20	2	10	18
SV3-355	7...	694	102	390	585	138	20	2	12	25

SV36-63 / SV16-63	6...	121	8	75	215	-	-	1,2	6	12
SV36-71 / SV16-71	6...	137	13,5	85	224	-	-	1,2	6	12
SV36-60 / SV16-80	6...	156	8	99	239	-	-	1,5	6	12
SV36-90 / SV16-90	6...	175	8	96	244	-	-	1,5	6	12
SV36-100 / SV16-100	6...	197	10	106	245	-	-	1,5	7	14
SV36-112 / SV16-112	6...	218	9	149	287	-	-	1,5	7	14
SV36-132 / SV16-132	6...	260	10	149	315	-	-	1,5	7	14
SV36-160	7...	311	-	163	350	-	-	2	-	-
SV36-180	7...	352	-	198	388	-	-	2	-	-
SV36-200	7...	393	-	205	390	-	-	2	-	-
SV36-225	7...	443	-	243	455	-	-	2	-	-
SV36-250	7...	482	-	255	475	-	-	2	-	-

8.0

Specificatii dimensionale ale motorului *Motor dimensional specifications*

Principalele dimensiuni de gabarit referitoare la urmatoarele serii de motoare sunt prezentate mai jos:

- IE3
- IE2
- IE1
- Polaritate dubla
- Monofazat
- Motoare cu frana

Datele se refera la productia standard; pentru tipurile de motoare care nu sunt prezentate in paginile urmatoare, va rugam sa contactati aLLindustrialL.

The main overall dimensions relating to the following motor series are given below:

- IE3
- IE2
- IE1
- Double polarity
- Single phase
- Brake motors

The data refer to standard production; for types of motors not shown in the following pages, please contact aLLindustrialL.

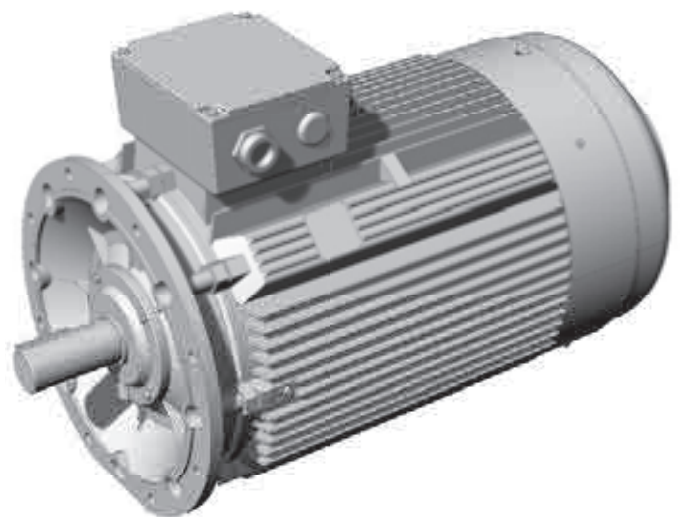
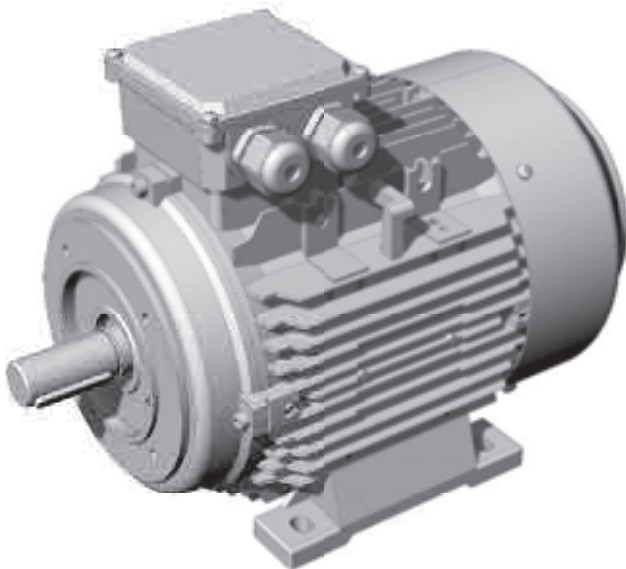

8. Date dimensionale ale motorului

◆ 8.1 6T3 7T3 IE3 trifazat / three phase

71-132 B3

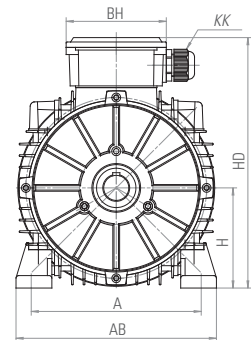
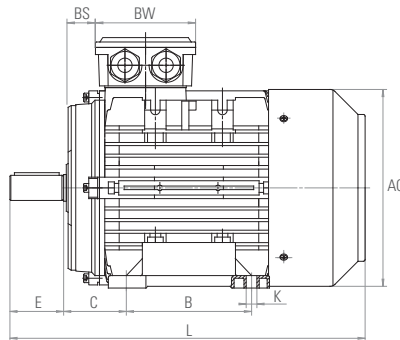

160-280 B3

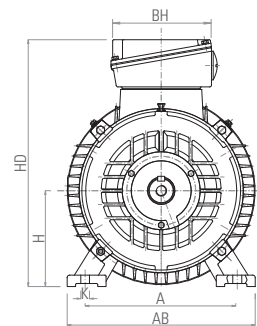
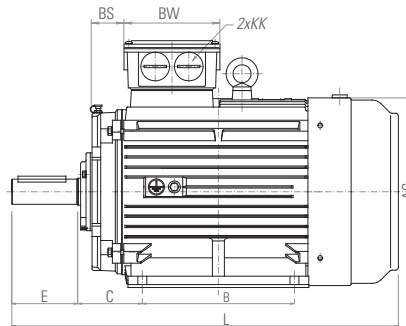

315-355 B3

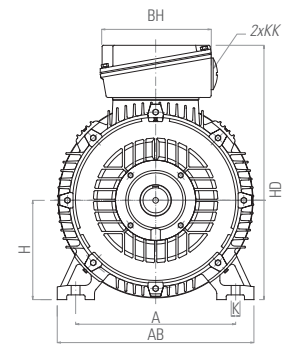
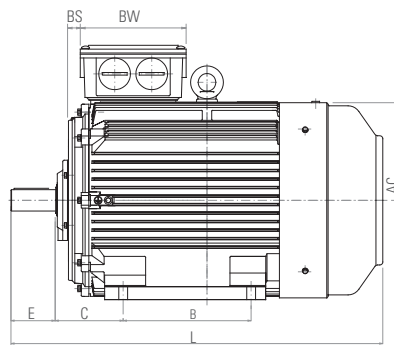

355LX-400 B3

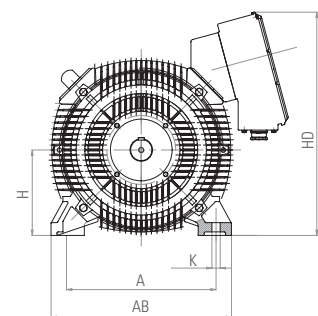
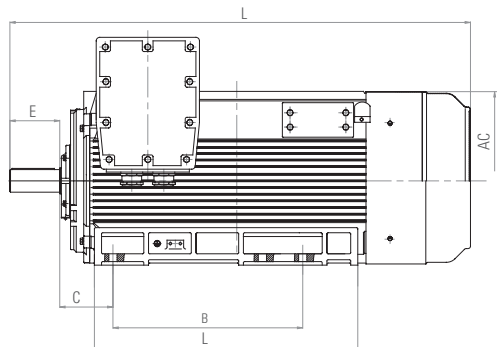

B3																		
	A	AB	B	C	K	AC	HD	D	DH	E	F	G	H	KK	L	BS	BW	BH
71-132 B3																		
71	112	132	90	45	7X10	145	183	14	M5X12	30	5	11	71	M20X1.5	255	20	94	94
80	125	160	100	50	10X15	165	210	19	M6X16	40	6	15,5	80	M20X1.5	277	27	105	105
90S	140	175	100	56	10X15	185	230	24	M8X20	50	8	20	90	M20X1.5	312	26	105	105
90L	140	175	125	56	10X15	185	230	24	M8X20	50	8	20	90	M20X1.5	337	26	105	105
90LB	140	175	125	56	10X15	185	230	24	M8X20	50	8	20	90	M20X1.5	365	26	105	105
100L	160	196	140	63	12X16	205	255	28	M10X22	60	8	24	100	M20X1.5	375	26	105	105
100LC	160	196	140	63	12X16	205	255	28	M10X22	60	8	24	100	M20X1.5	411	26	105	105
112M(MB2)	190	220	140	70	12X16	230	278	28	M10X22	60	8	24	112	M25X1.5	400	34	112	112
112MB	190	220	140	70	12X16	230	278	28	M10X22	60	8	24	112	M25X1.5	417	34	112	112
132S	216	252	140	89	12X16	270	320	38	M12X28	80	10	33	132	M25X1.5	460	40	112	112
132M	216	252	178	89	12X16	270	320	38	M12X28	80	10	33	132	M25X1.5	500	40	112	112
160-280 B3																		
160M	254	320	210	108	14X19	330	425	42	M16X36	110	12	37	160	M32X1.5	660	92	150	180
160L	254	320	254	108	14X19	330	425	42	M16X36	110	12	37	160	M32X1.5	685	92	150	180
180M	279	350	241	121	14X22	380	460	48	M16X36	110	14	42.5	180	M32X1.5	725	92	150	180
180L	279	350	279	121	14X22	380	460	48	M16X36	110	14	42.5	180	M32X1.5	775	92	150	180
200L	318	395	305	133	18X25	420	515	55	M20X42	110	16	49	200	M40X1.5	785	100	180	215
225S4	356	436	286	149	18X28	465	560	60	M20X42	140	18	53	225	M40X1.5	835	100	180	215
225M2	356	436	311	149	18X28	465	560	55	M20X42	110	16	49	225	M40X1.5	825	100	180	215
225M4-6	356	436	311	149	18X28	465	560	60	M20X42	140	18	53	225	M40X1.5	860	100	180	215
250M2	406	495	349	168	24X33	520	625	60	M20X42	140	18	53	250	M50X1.5	940	105	215	260
250M4-6	406	495	349	168	24X33	520	625	65	M20X42	140	18	58	250	M50X1.5	945	105	215	260
280S2	457	550	368	190	24X35	570	685	65	M20X42	140	18	58	280	M50X1.5	970	105	215	260
280S4-6	457	550	368	190	24X35	570	685	75	M20X42	140	20	67.5	280	M50X1.5	975	105	215	260
280M2	457	550	419	190	24X35	570	685	65	M20X42	140	18	58	280	M50X1.5	1010	105	215	260
280M4-6	457	550	419	190	24X35	570	685	75	M20X42	140	20	67.5	280	M50X1.5	1015	105	215	260
315-355 B3																		
315S2	508	630	406	216	28X45	620	815	65	M20X42	140	18	58	315	M63X1.5	1150	105	285	330
315S4-6	508	630	406	216	28X45	620	815	80	M20X42	170	22	71	315	M63X1.5	1185	105	285	330
315M2	508	630	457	216	28X45	620	815	65	M20X42	140	18	58	315	M63X1.5	1260	105	285	330
315M4-6	508	630	457	216	28X45	620	815	80	M20X42	170	22	71	315	M63X1.5	1295	105	285	330
315L2	508	630	508	216	28X45	620	815	65	M20X42	140	18	58	315	M63X1.5	1265	105	285	330
315L4-6	508	630	508	216	28X45	620	815	80	M20X42	170	22	71	315	M63X1.5	1310	105	285	330
355M2	610	735	560	254	28X49	700	1000	75	M24X50	140	20	67.5	355	M63X1.5	1510	100	360	410
355M4-6	610	735	560	254	28X49	700	1000	100	M24X50	210	28	86	355	M63X1.5	1640	100	360	410
355L2	610	735	630	254	28X49	700	1000	75	M24X50	140	20	67.5	355	M63X1.5	1610	100	360	410
355L4-6	610	735	630	254	28X49	700	1000	100	M24X50	210	28	86	355	M63X1.5	1670	100	360	410
355LX-400 B3																		
355LX2	630	760	800	254	35	760	980	75	M20X42	140	20	67,5	355	-/-	1850	105	430	485
355LX4-6	630	760	800	254	35	760	980	100	M20X42	210	28	86	355	-/-	1950	105	430	485
400 2	710	840	900	280	35	840	1060	85	M24X50	170	22	76	400	-/-	1910	147	430	485
400 4-6	710	840	900	280	35	840	1060	120	M24X50	210	32	109	400	-/-	1990	147	430	485

Datele tehnice si performantele se pot modifica / Technical data and performances may change



6T3 7T3 IE3 trifazat / three phase

71-132 B5

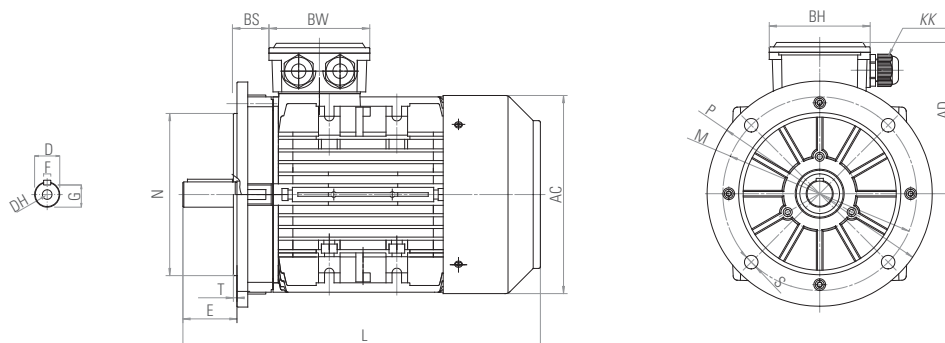

160-280 B5

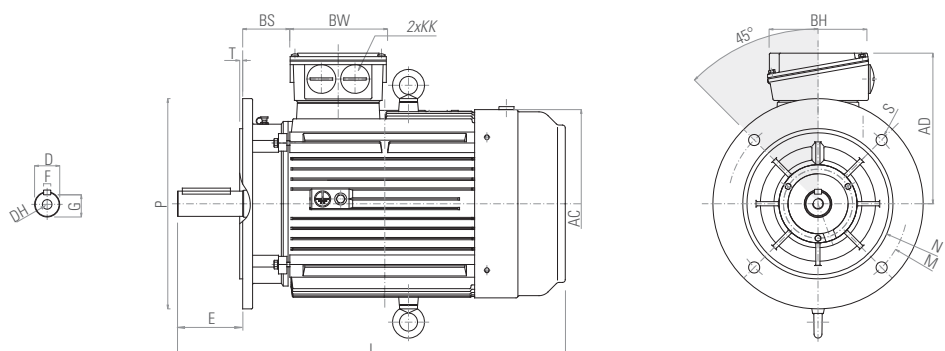

315-355 B5

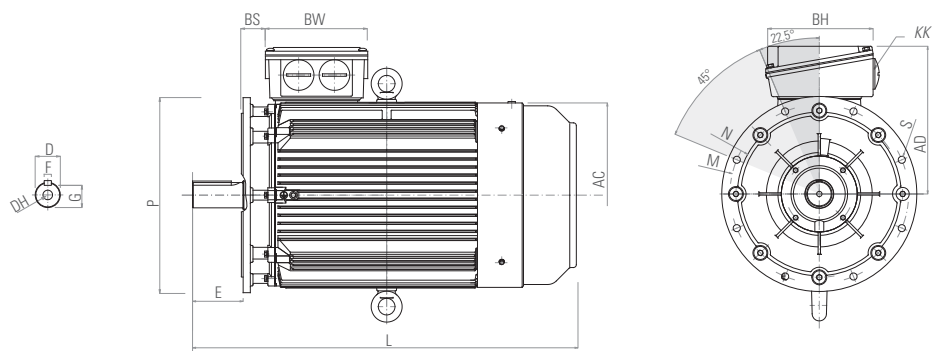

355LX-400 B5

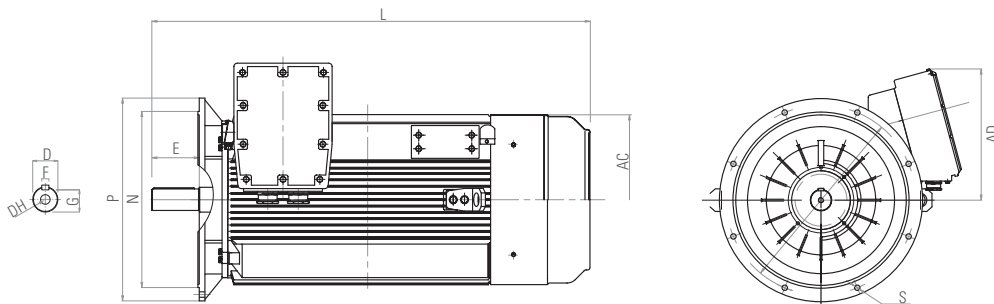

B5	P	M	N	S	T	AC	HD	D	DH	E	F	G	H	KK	L	BS	BW	BH
71-132 B5																		
71	112	132	90	45	7X10	145	183	14	M5X12	30	5	11	71	M20X1.5	255	20	94	94
80	200	165	130	12	3.5	165	130	19	M6X16	40	6	15.5	80	M20X1.5	277	27	105	105
90S	200	165	130	12	3.5	185	140	24	M8X20	50	8	20	90	M20X1.5	312	26	105	105
90L	200	165	130	12	3.5	185	140	24	M8X20	50	8	20	90	M20X1.5	337	26	105	105
90LB	200	165	130	12	3.5	185	140	24	M8X20	50	8	20	90	M20X1.5	365	26	105	105
100L	250	215	180	15	4	205	155	28	M10X22	60	8	24	100	M20X1.5	375	26	105	105
100LC	250	215	180	15	4	205	155	28	M10X22	60	8	24	100	M20X1.5	411	26	105	105
112M(MB2)	250	215	180	15	4	230	166	28	M10X22	60	8	24	112	M25X1.5	400	34	112	112
112MB	250	215	180	15	4	230	166	28	M10X22	60	8	24	112	M25X1.5	417	34	112	112
132S	300	265	230	15	4	270	188	38	M12X28	80	10	33	132	M25X1.5	460	40	112	112
132M	300	265	230	15	4	270	188	38	M12X28	80	10	33	132	M25X1.5	500	40	112	112
160-280 B5																		
160M	350	300	250	18.5	5	330	265	42	M16X36	110	12	37	160	M32X1.5	660	92	150	180
160L	350	300	250	18.5	5	330	265	42	M16X36	110	12	37	160	M32X1.5	685	92	150	180
180M	350	300	250	18.5	5	380	280	48	M16X36	110	14	42.5	180	M32X1.5	725	92	150	180
180L	350	300	250	18.5	5	380	280	48	M16X36	110	14	42.5	180	M32X1.5	775	92	150	180
200L	400	350	300	18.5	5	420	315	55	M20X42	110	16	49	200	M40X1.5	785	100	180	215
225S4	450	400	350	18.5	5	465	335	60	M20X42	140	18	53	225	M40X1.5	835	100	180	215
225M2	450	400	350	18.5	5	465	335	55	M20X42	110	16	49	225	M40X1.5	825	100	180	215
225M4-6	450	400	350	18.5	5	465	335	60	M20X42	140	18	53	225	M40X1.5	860	100	180	215
250M2	550	500	450	18.5	5	520	375	60	M20X42	140	18	53	250	M50X1.5	940	105	215	260
250M4-6	550	500	450	18.5	5	520	375	65	M20X42	140	18	58	250	M50X1.5	945	105	215	260
280S2	550	500	450	18.5	5	570	405	65	M20X42	140	18	58	280	M50X1.5	970	105	215	260
280S4-6	550	500	450	18.5	5	570	405	75	M20X42	140	20	67.5	280	M50X1.5	975	105	215	260
280M2	550	500	450	18.5	5	570	405	65	M20X42	140	18	58	280	M50X1.5	1010	105	215	260
280M4-6	550	500	450	18.5	5	570	405	75	M20X42	140	20	67.5	280	M50X1.5	1015	105	215	260
315-355 B5																		
315S2	660	600	550	24	6	620	500	65	M20X42	140	18	58	315	M63X1.5	1150	105	285	330
315S4-6	660	600	550	24	6	620	500	80	M20X42	170	22	71	315	M63X1.5	1185	105	285	330
315M2	660	600	550	24	6	620	500	65	M20X42	140	18	58	315	M63X1.5	1260	105	285	330
315M4-6	660	600	550	24	6	620	500	80	M20X42	170	22	71	315	M63X1.5	1295	105	285	330
315L2	660	600	550	24	6	620	500	65	M20X42	140	18	58	315	M63X1.5	1265	105	285	330
315L4-6	660	600	550	24	6	620	500	80	M20X42	170	22	71	315	M63X1.5	1310	105	285	330
355M2	800	740	680	24	6	700	645	75	M24X50	140	20	67.5	355	M63X1.5	1510	100	360	410
355M4-6	800	740	680	24	6	700	645	100	M24X50	210	28	86	355	M63X1.5	1640	100	360	410
355L2	800	740	680	24	6	700	645	75	M24X50	140	20	67.5	355	M63X1.5	1610	100	360	410
355L4-6	800	740	680	24	6	700	645	100	M24X50	210	28	86	355	M63X1.5	1670	100	360	410
355LX-400 B5																		
355LX2	900	840	780	24	6	760	625	75	M20X42	140	20	67.5	355	-/-	1850	105	430	485
355LX4-6	900	840	780	24	6	760	625	100	M20X42	210	28	86	355	-/-	1950	105	430	485
400 2	1000	940	880	28	6	840	660	85	M24X50	170	22	76	400	-/-	1910	147	430	485
400 4-6	1000	940	880	28	6	840	660	120	M24X50	210	32	109	400	-/-	1990	147	430	485

Nota: de la MEC225 inclus incolo, flansa B5 are 8 orificii de montare. Datele tehnice si performantele pot fi modificate
 Note: from MEC225 included onwards, the B5 flange has 8 mounting holes. Technical data and performances may change

6T3 7T3 IE3 trifazat / three phase

71÷160

71-132 B14

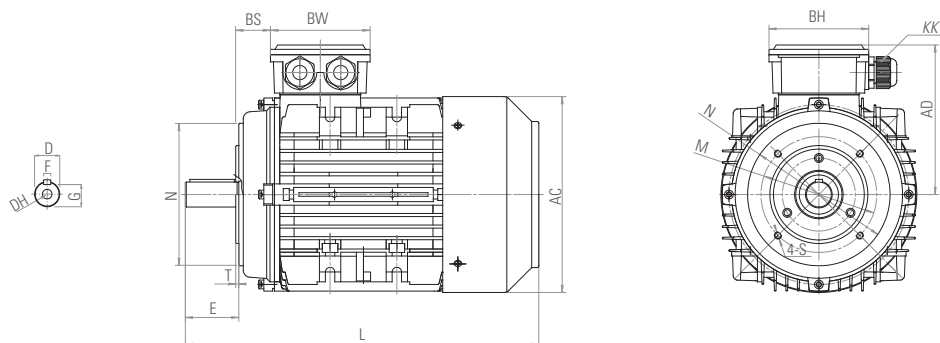

160 B14

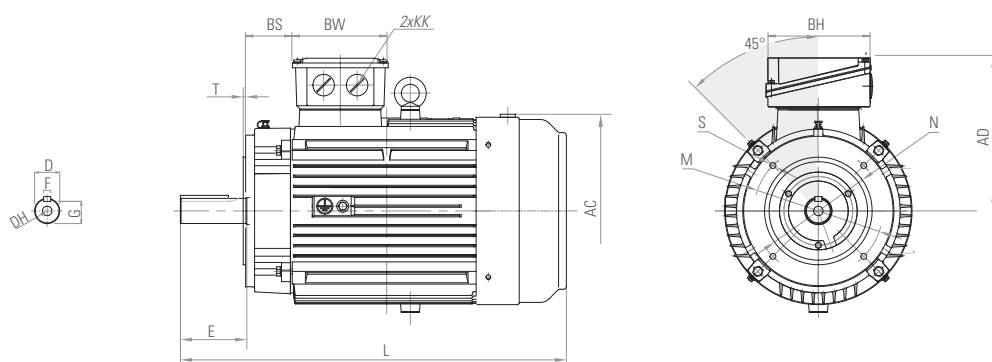

B14

	P	M	N	S	T	AC	AD	D	DH	E	F	G	H	KK	L	BS	BW	BH
71-132 B14																		
71	105	85	70	M6	2.5	145	112	14	M5X12	30	5	11	71	M20X1.5	255	20	94	94
80	120	100	80	M6	3	165	130	19	M6X16	40	6	15.5	80	M20X1.5	277	27	105	105
90S	140	115	95	M8	3	185	140	24	M8X20	50	8	20	90	M20X1.5	312	26	105	105
90L	140	115	95	M8	3	185	140	24	M8X20	50	8	20	90	M20X1.5	337	26	105	105
90LB	140	115	95	M8	3	185	140	24	M8X20	50	8	20	90	M20X1.5	365	26	105	105
100L	160	130	110	M8	3.5	205	155	28	M10X22	60	8	24	100	M20X1.5	375	34	112	112
100LC	160	130	110	M8	3.5	205	155	28	M10X22	60	8	24	100	M20X1.5	411	34	112	112
112M(MB2)	160	130	110	M8	3.5	230	166	28	M10X22	60	8	24	112	M25X1.5	400	34	112	112
112MB	160	130	110	M8	3.5	230	166	28	M10X22	60	8	24	112	M25X1.5	417	34	112	112
132S	200	165	130	M10	3.5	270	188	38	M12X28	80	10	33	132	M25X1.5	460	40	112	112
132M	200	165	130	M10	3.5	270	188	38	M12X28	80	10	33	132	M25X1.5	500	40	112	112
160 B14																		
160M	250	215	180	M12	4	330	265	42	M16X36	110	12	37	160	M32X1.5	660	92	150	180
160L	250	215	180	M12	4	330	265	42	M16X36	110	12	37	160	M32X1.5	685	92	150	180

Nota: MEC71 B14 are 8 gauri filetate. Datele tehnice si performantele pot fi modificate
 Note: MEC71 B14 has 8 threaded holes. Technical data and performances may change

8. Specificatii dimensionale ale motoarelor trifazate

◆ 8.2 6T2 7T2 IE2 trifazat / three phase

71-132 B3

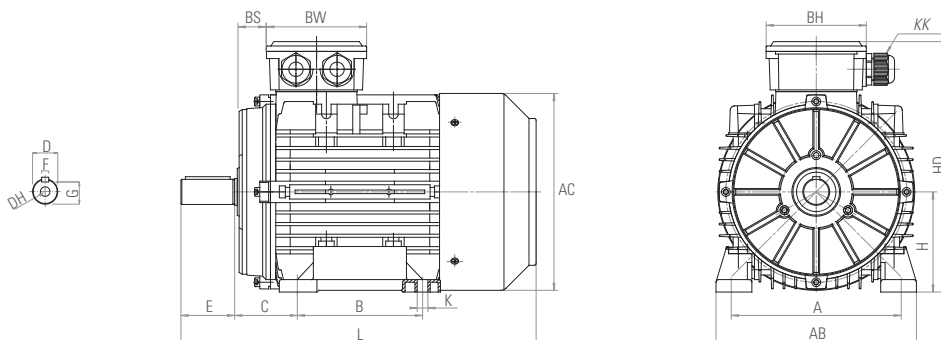

160-280 B3

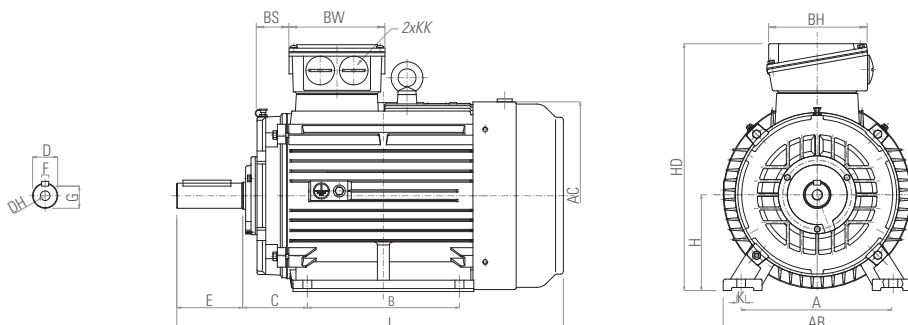

315-355 B3

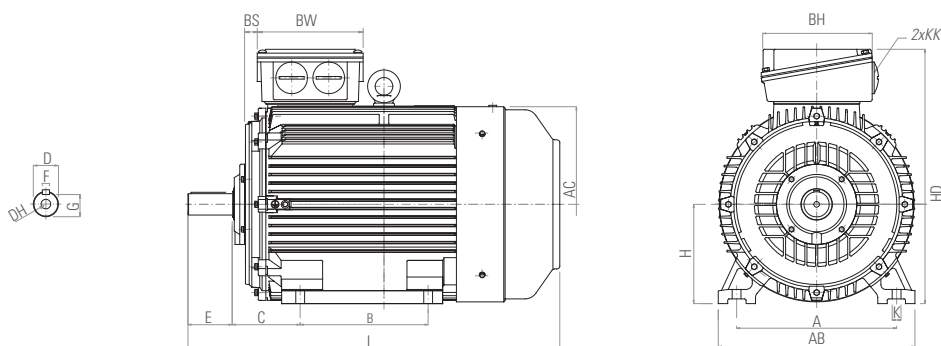

355LX-400 B3

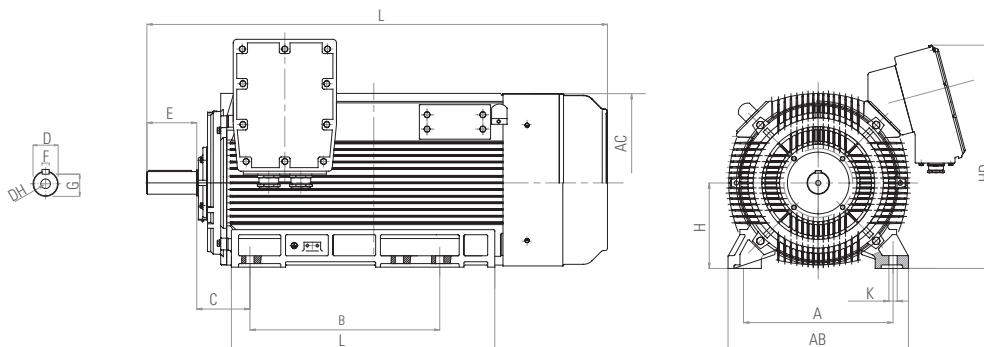

B3	A	AB	B	C	K	AC	HD	D	DH	E	F	G	H	KK	L	BS	BW	BH
71-132 B3																		
71	112	132	90	45	7X10	145	183	14	M5X12	30	5	11	71	M20X1.5	255	20	94	94
80	125	160	100	50	10X15	165	210	19	M6X16	40	6	15,5	80	M20X1.5	277	27	105	105
90S	140	175	100	56	10X15	185	230	24	M8X20	50	8	20	90	M20X1.5	312	26	105	105
90L	140	175	125	56	10X15	185	230	24	M8X20	50	8	20	90	M20X1.5	337	26	105	105
90LB	140	175	125	56	10X15	185	230	24	M8X20	50	8	20	90	M20X1.5	365	26	105	105
100L	160	196	140	63	12X16	205	255	28	M10X22	60	8	24	100	M20X1.5	375	26	105	105
112	190	220	140	70	12X16	230	278	28	M10X22	60	8	24	112	M25X1.5	400	34	112	112
132S	216	252	140	89	12X16	270	320	38	M12X28	80	10	33	132	M25X1.5	460	40	112	112
132M	216	252	178	89	12X16	270	320	38	M12X28	80	10	33	132	M25X1.5	500	40	112	112
160-280 B3																		
160M	254	320	210	108	14X19	330	425	42	M16X36	110	12	37	160	M32X1.5	620	92	150	180
160L	254	320	254	108	14X19	330	425	42	M16X36	110	12	37	160	M32X1.5	665	92	150	180
180M	279	350	241	121	14X22	380	460	48	M16X36	110	14	42,5	180	M32X1.5	690	92	150	180
180L	279	350	279	121	14X22	380	460	48	M16X36	110	14	42,5	180	M32X1.5	725	92	150	180
200L	318	395	305	133	18X25	420	515	55	M20X42	110	16	49	200	M40X1.5	785	100	180	215
225S4	356	436	286	149	18X28	465	560	60	M20X42	140	18	53	225	M40X1.5	835	100	180	215
225M2	356	436	311	149	18X28	465	560	55	M20X42	110	16	49	225	M40X1.5	825	100	180	215
225M4-6	356	436	311	149	18X28	465	560	60	M20X42	140	18	53	225	M40X1.5	860	100	180	215
250M2	406	495	349	168	24X33	520	625	60	M20X42	140	18	53	250	M50X1.5	940	105	215	260
250M4-6	406	495	349	168	24X33	520	625	65	M20X42	140	18	58	250	M50X1.5	945	105	215	260
280S2	457	550	368	190	24X35	570	685	65	M20X42	140	18	58	280	M50X1.5	970	105	215	260
280S4-6	457	550	368	190	24X35	570	685	75	M20X42	140	20	67,5	280	M50X1.5	975	105	215	260
280M2	457	550	419	190	24X35	570	685	65	M20X42	140	18	58	280	M50X1.5	1010	105	215	260
280M4-6	457	550	419	190	24X35	570	685	75	M20X42	140	20	67,5	280	M50X1.5	1015	105	215	260
315-355 B3																		
315S2	508	630	406	216	28X45	620	815	65	M20X42	140	18	58	315	M63X1.5	1150	105	285	330
315S4-6	508	630	406	216	28X45	620	815	80	M20X42	170	22	71	315	M63X1.5	1185	105	285	330
315M2	508	630	457	216	28X45	620	815	65	M20X42	140	18	58	315	M63X1.5	1260	105	285	330
315M4-6	508	630	457	216	28X45	620	815	80	M20X42	170	22	71	315	M63X1.5	1295	105	285	330
315L2	508	630	508	216	28X45	620	815	65	M20X42	140	18	58	315	M63X1.5	1265	105	285	330
315L4-6	508	630	508	216	28X45	620	815	80	M20X42	170	22	71	315	M63X1.5	1310	105	285	330
355M2	610	735	560	254	28X49	700	1000	75	M24X50	140	20	67,5	355	M63X1.5	1510	100	360	410
355M4-6	610	735	560	254	28X49	700	1000	100	M24X50	210	28	86	355	M63X1.5	1570	100	360	410
355L2	610	735	630	254	28X49	700	1000	75	M24X50	140	20	67,5	355	M63X1.5	1610	100	360	410
355L4-6	610	735	630	254	28X49	700	1000	100	M24X50	210	28	86	355	M63X1.5	1640	100	360	410
355LX-400 B3																		
355LX2	630	760	800	254	35	760	980	75	M20X42	140	20	67,5	355	-/-	1855	105	430	485
355LX4-6	630	760	800	254	35	760	980	100	M20X42	210	28	86	355	-/-	1950	105	430	485
400 2	710	840	900	280	35	840	1060	85	M24X50	170	22	76	400	-/-	1910	147	430	485
400 4-6	710	840	900	280	35	840	1060	120	M24X50	210	32	109	400	-/-	1990	147	430	485

Datele tehnice si performantele se pot modifica / Technical data and performances may change

8. Specificatii dimensionale ale motoarelor trifazate

6T2 7T2 IE2 trifazat / three phase

71-132 B5

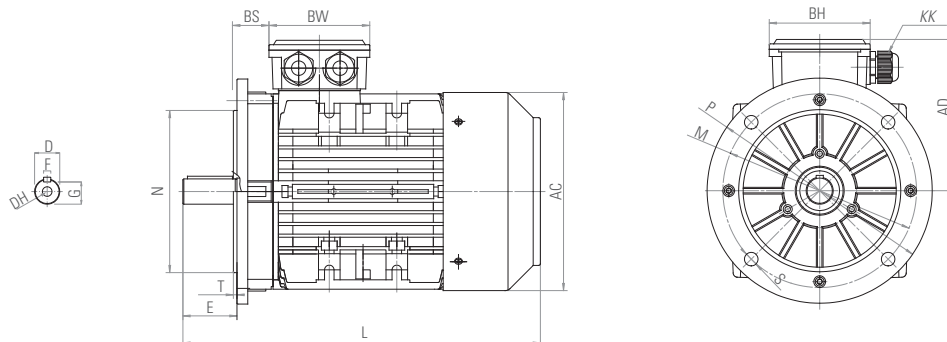

160-280 B5

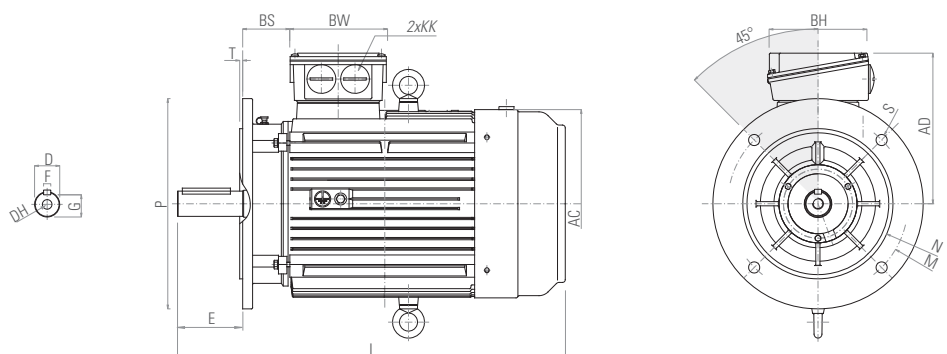

315-355 B5

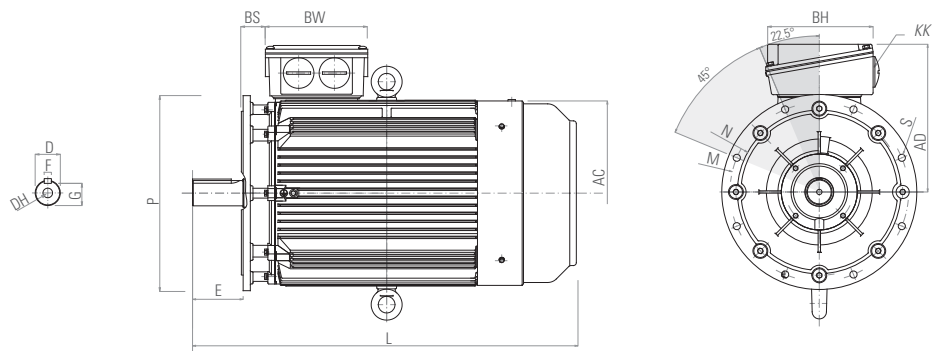

355LX-400 B5

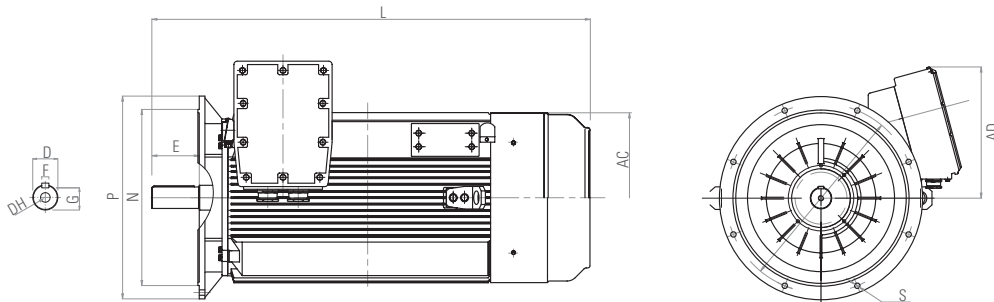

B5	P	M	N	S	T	AC	AD	D	DH	E	F	G	H	KK	L	BS	BW	BH
71-132 B5																		
71	160	130	110	10	3.5	145	112	14	M5X12	30	5	11	71	M20X1.5	255	20	94	94
80	200	165	130	12	3.5	165	130	19	M6X16	40	6	15.5	80	M20X1.5	277	27	105	105
90S	200	165	130	12	3.5	185	140	24	M8X20	50	8	20	90	M20X1.5	312	26	105	105
90L	200	165	130	12	3.5	185	140	24	M8X20	50	8	20	90	M20X1.5	337	26	105	105
90LB	200	165	130	12	3.5	185	140	24	M8X20	50	8	20	90	M20X1.5	365	26	105	105
100L	250	215	180	15	4	205	155	28	M10X22	60	8	24	100	M20X1.5	375	26	105	105
112	250	215	180	15	4	230	166	28	M10X22	60	8	24	112	M25X1.5	400	34	112	112
132S	300	265	230	15	4	270	188	38	M12X28	80	10	33	132	M25X1.5	460	40	112	112
132M	300	265	230	15	4	270	188	38	M12X28	80	10	33	132	M25X1.5	500	40	112	112
160-280 B5																		
160M	350	300	250	18.5	5	330	265	42	M16X36	110	12	37	160	M32X1.5	620	92	150	180
160L	350	300	250	18.5	5	330	265	42	M16X36	110	12	37	160	M32X1.5	665	92	150	180
180M	350	300	250	18.5	5	380	280	48	M16X36	110	14	42.5	180	M32X1.5	690	92	150	180
180L	350	300	250	18.5	5	380	280	48	M16X36	110	14	42.5	180	M32X1.5	725	92	150	180
200L	400	350	300	18.5	5	420	315	55	M20X42	110	16	49	200	M40X1.5	785	100	180	215
225S4	450	400	350	18.5	5	465	335	60	M20X42	140	18	53	225	M40X1.5	835	100	180	215
225M2	450	400	350	18.5	5	465	335	55	M20X42	110	16	49	225	M40X1.5	825	100	180	215
225M4-6	450	400	350	18.5	5	465	335	60	M20X42	140	18	53	225	M40X1.5	860	100	180	215
250M2	550	500	450	18.5	5	520	375	60	M20X42	140	18	53	250	M50X1.5	940	105	215	260
250M4-6	550	500	450	18.5	5	520	375	65	M20X42	140	18	58	250	M50X1.5	945	105	215	260
280S2	550	500	450	18.5	5	570	405	65	M20X42	140	18	58	280	M50X1.5	970	105	215	260
280S4-6	550	500	450	18.5	5	570	405	75	M20X42	140	20	67.5	280	M50X1.5	975	105	215	260
280M2	550	500	450	18.5	5	570	405	65	M20X42	140	18	58	280	M50X1.5	1010	105	215	260
280M4-6	550	500	450	18.5	5	570	405	75	M20X42	140	20	67.5	280	M50X1.5	1015	105	215	260
315-355 B5																		
315S2	660	600	550	24	6	620	500	65	M20X42	140	18	58	315	M63X1.5	1150	105	285	330
315S4-6	660	600	550	24	6	620	500	80	M20X42	170	22	71	315	M63X1.5	1185	105	285	330
315M2	660	600	550	24	6	620	500	65	M20X42	140	18	58	315	M63X1.5	1260	105	285	330
315M4-6	660	600	550	24	6	620	500	80	M20X42	170	22	71	315	M63X1.5	1295	105	285	330
315L2	660	600	550	24	6	620	500	65	M20X42	140	18	58	315	M63X1.5	1265	105	285	330
315L4-6	660	600	550	24	6	620	500	80	M20X42	170	22	71	315	M63X1.5	1310	105	285	330
355M2	800	740	680	24	6	700	645	75	M24X50	140	20	67.5	355	M63X1.5	1510	100	360	410
355M4-6	800	740	680	24	6	700	645	100	M24X50	210	28	86	355	M63X1.5	1640	100	360	410
355L2	800	740	680	24	6	700	645	75	M24X50	140	20	67.5	355	M63X1.5	1610	100	360	410
355L4-6	800	740	680	24	6	700	645	100	M24X50	210	28	86	355	M63X1.5	1640	100	360	410
355LX-400 B5																		
355LX2	900	840	780	24	6	760	625	75	M20X42	140	20	67.5	355	-/-	1855	105	430	485
355LX4-6	900	840	780	24	6	760	625	100	M20X42	210	28	86	355	-/-	1950	105	430	485
400 2	1000	940	880	28	6	840	660	85	M24X50	170	22	76	400	-/-	1910	147	430	485
400 4-6	1000	940	880	28	6	840	660	120	M24X50	210	32	109	400	-/-	1990	147	430	485

Nota: de la MEC225 inclus incolo, flansa B5 are 8 orificii de montare. Datele tehnice si performantele pot fi modificate
 Note: from MEC225 included onwards, the B5 flange has 8 mounting holes. Technical data and performances may change

6T2 7T2 IE2 trifazat / three phase

71÷160

71-132 B14

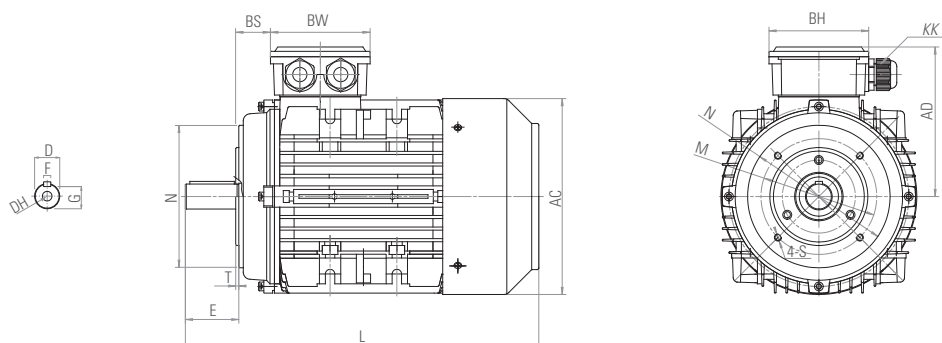

160 B14

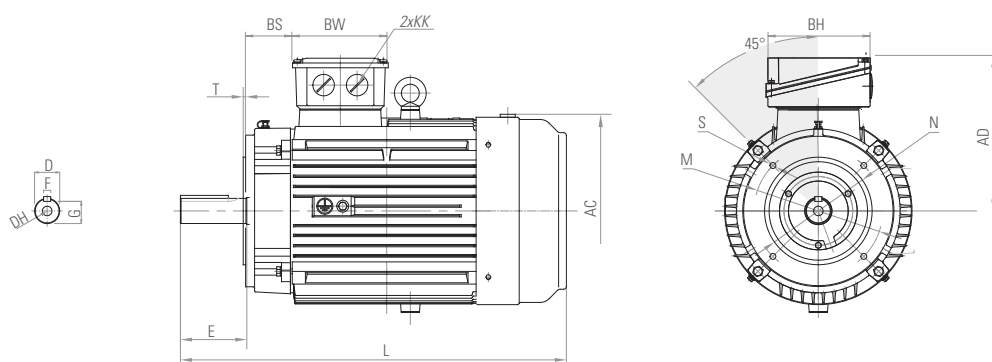

B14																		
	P	M	N	S	T	AC	AD	D	DH	E	F	G	H	KK	L	BS	BW	BH
71-132 B14																		
71	105	85	70	M6	2.5	145	112	14	M5X12	30	5	11	71	M20X1.5	255	20	94	94
80	120	100	80	M6	3	165	130	19	M6X16	40	6	15.5	80	M20X1.5	277	27	105	105
90S	140	115	95	M8	3	185	140	24	M8X20	50	8	20	90	M20X1.5	312	26	105	105
90L	140	115	95	M8	3	185	140	24	M8X20	50	8	20	90	M20X1.5	337	26	105	105
90LB	140	115	95	M8	3	185	140	24	M8X20	50	8	20	90	M20X1.5	365	34	112	112
100L	160	130	110	M8	3.5	205	155	28	M10X22	60	8	24	100	M20X1.5	375	34	112	112
112	160	130	110	M8	3.5	230	166	28	M10X22	60	8	24	112	M25X1.5	400	34	112	112
132S	200	165	130	M10	3.5	270	188	38	M12X28	80	10	33	132	M25X1.5	460	40	112	112
132M	200	165	130	M10	3.5	270	188	38	M12X28	80	10	33	132	M25X1.5	500	40	112	112
160 B14																		
160M	250	215	180	M12	4	330	265	42	M16X36	110	12	37	160	M32X1.5	660	92	150	180
160L	250	215	180	M12	4	330	265	42	M16X36	110	12	37	160	M32X1.5	665	92	150	180

Nota: MEC71 B14 are 8 gauri filetate. Datele tehnice si performantele pot fi modificate
 Note: MEC71 B14 has 8 threaded holes. Technical data and performances may change

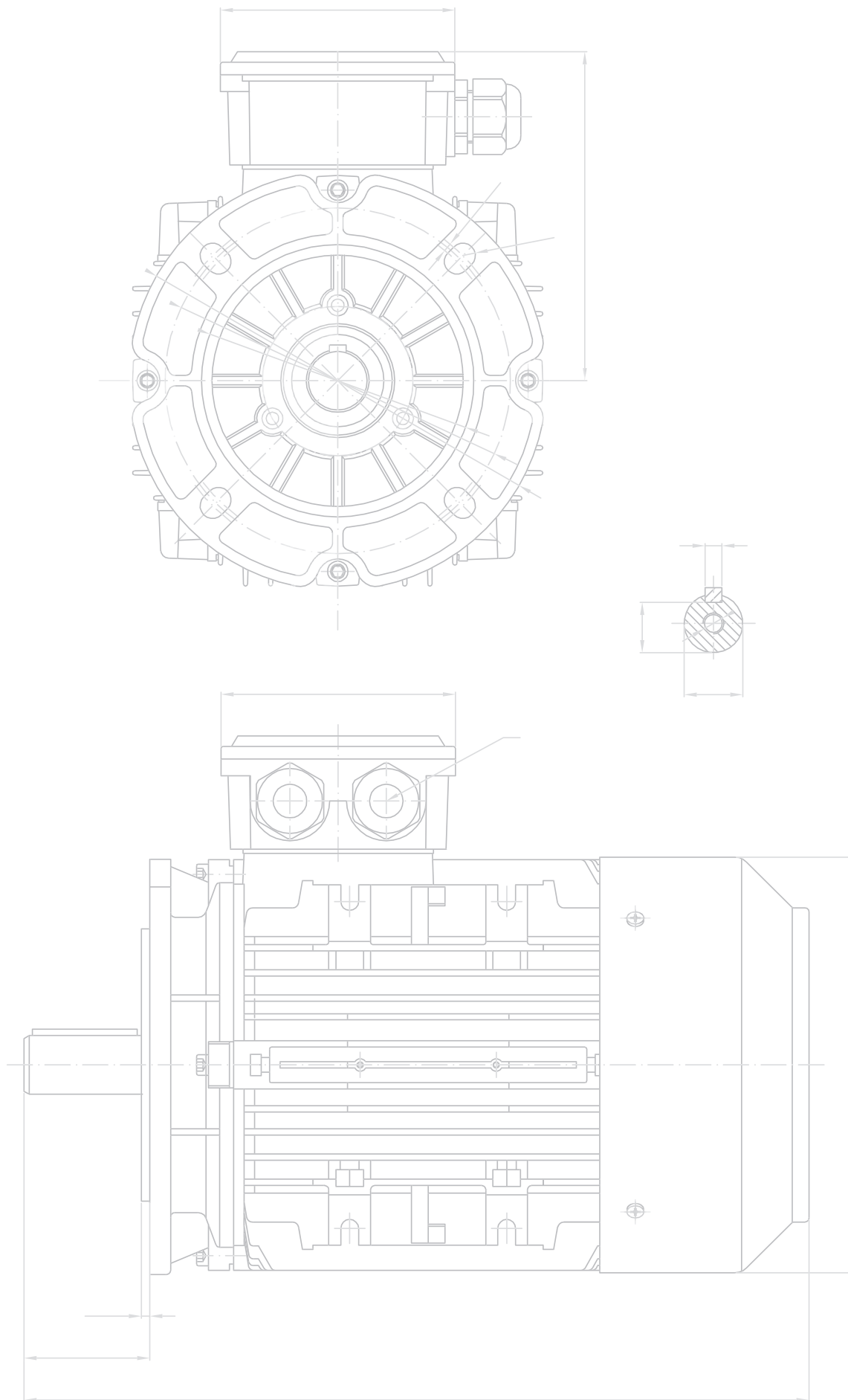

◆ 8.3 6T1 7T1 IE1 trifazat / *three-phase motor*

56-132 B3

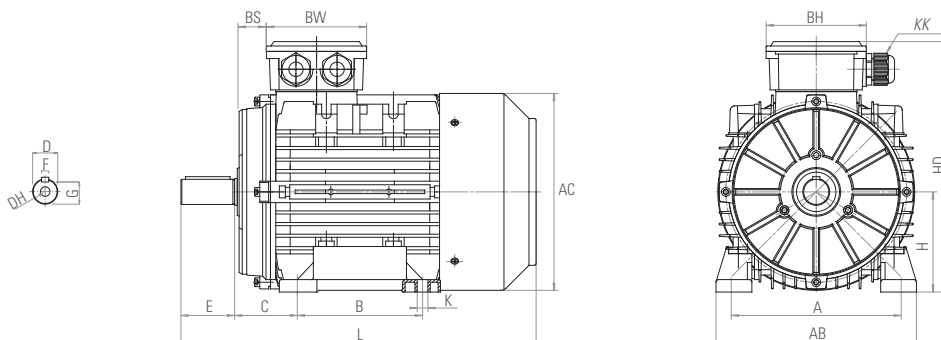

160-280 B3

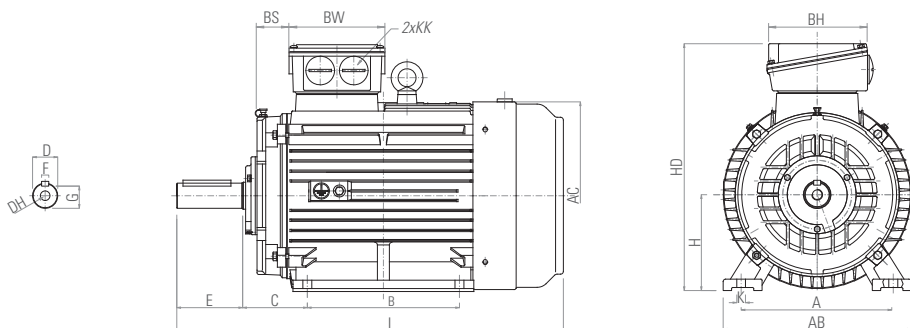

315-355 B3

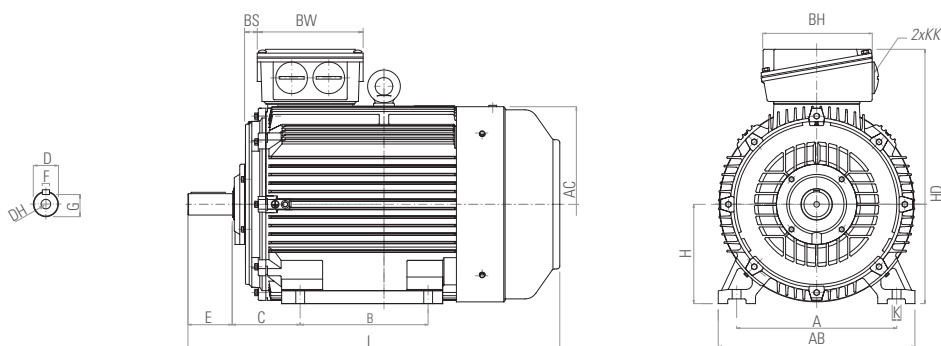

355LX-450 B3

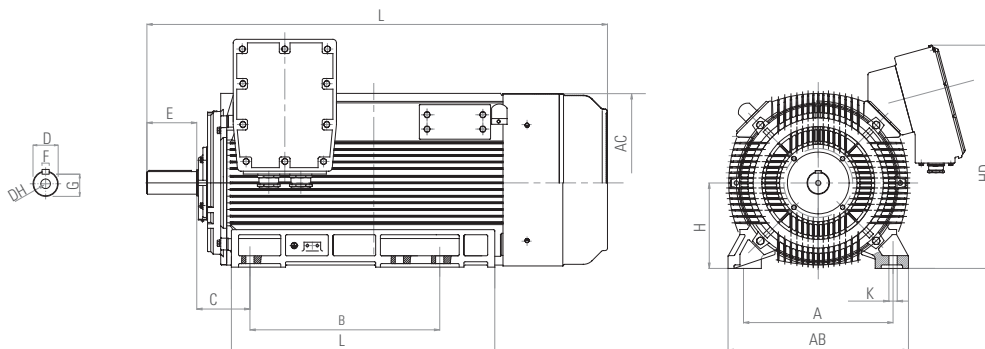

B3	A	AB	B	C	K	AC	HD	D	DH	E	F	G	H	KK	L	BS	BW	BH
56-132 B3																		
56	90	110	71	36	5.8X8.8	115	153	9	M3X8	20	3	7.2	56	M20X1.5	195	14	88	88
63	100	120	80	40	7X10	130	168	11	M4X10	23	4	8.5	63	M20X1.5	215	14	94	94
71	112	132	90	45	7X10	145	183	14	M5X12	30	5	11	71	M20X1.5	255	20	94	94
80	125	160	100	50	10X15	165	210	19	M6X16	40	6	15.5	80	M20X1.5	277	27	105	105
90S	140	175	100	56	10X15	185	230	24	M8X20	50	8	20	90	M20X1.5	312	26	105	105
90L	140	175	125	56	10X15	185	230	24	M8X20	50	8	20	90	M20X1.5	337	26	105	105
100L	160	196	140	63	12X16	205	255	28	M10X22	60	8	24	100	M20X1.5	375	26	105	105
112	190	220	140	70	12X16	230	278	28	M10X22	60	8	24	112	M25X1.5	400	34	112	112
132S	216	252	140	89	12X16	270	320	38	M12X28	80	10	33	132	M25X1.5	460	40	112	112
132M	216	252	178	89	12X16	270	320	38	M12X28	80	10	33	132	M25X1.5	500	40	112	112
160-280 B3																		
160M	254	320	210	108	14X19	330	425	42	M16X36	110	12	37	160	M32X1.5	605	92	150	180
160L	254	320	254	108	14X19	330	425	42	M16X36	110	12	37	160	M32X1.5	650	92	150	180
180M	279	350	241	121	14X22	380	460	48	M16X36	110	14	42.5	180	M32X1.5	675	92	150	180
180L	279	350	279	121	14X22	380	460	48	M16X36	110	14	42.5	180	M32X1.5	715	92	150	180
200L	318	395	305	133	18X25	420	515	55	M20X42	110	16	49	200	M40X1.5	765	100	180	215
225S4	356	436	286	149	18X28	465	560	60	M20X42	140	18	53	225	M40X1.5	820	100	180	215
225M2	356	436	311	149	18X28	465	560	55	M20X42	110	16	49	225	M40X1.5	815	100	180	215
225M4-8	356	436	311	149	18X28	465	560	60	M20X42	140	18	53	225	M40X1.5	845	100	180	215
250M2	406	495	349	168	24X33	520	625	60	M20X42	140	18	53	250	M50X1.5	930	105	215	260
250M4-8	406	495	349	168	24X33	520	625	65	M20X42	140	18	58	250	M50X1.5	930	105	215	260
280S2	457	550	368	190	24X35	570	685	65	M20X42	140	18	58	280	M50X1.5	960	105	215	260
280S4-8	457	550	368	190	24X35	570	685	75	M20X42	140	20	67.5	280	M50X1.5	975	105	215	260
280M2	457	550	419	190	24X35	570	685	65	M20X42	140	18	58	280	M50X1.5	1000	105	215	260
280M4-8	457	550	419	190	24X35	570	685	75	M20X42	140	20	67.5	280	M50X1.5	1015	105	215	260
315-355 B3																		
315S2	508	630	406	216	28X45	620	815	65	M20X42	140	18	58	315	M63X1.5	1150	105	285	330
315S4-8	508	630	406	216	28X45	620	815	80	M20X42	170	22	71	315	M63X1.5	1185	105	285	330
315M2	508	630	457	216	28X45	620	815	65	M20X42	140	18	58	315	M63X1.5	1260	105	285	330
315M4-8	508	630	457	216	28X45	620	815	80	M20X42	170	22	71	315	M63X1.5	1295	105	285	330
315L2	508	630	508	216	28X45	620	815	65	M20X42	140	18	58	315	M63X1.5	1265	105	285	330
315L4-8	508	630	508	216	28X45	620	815	80	M20X42	170	22	71	315	M63X1.5	1305	105	285	330
355M2	610	735	560	254	28X49	700	1000	75	M24X50	140	20	67.5	355	M63X1.5	1510	100	360	410
355M4-8	610	735	560	254	28X49	700	1000	100	M24X50	210	28	86	355	M63X1.5	1570	100	360	410
355L2	610	735	630	254	28X49	700	1000	75	M24X50	140	20	67.5	355	M63X1.5	1610	100	360	410
355L4-8	610	735	630	254	28X49	700	1000	100	M24X50	210	28	86	355	M63X1.5	1640	100	360	410
355LX-400 B3																		
355LX2	630	760	800	254	35	760	980	75	M20X42	140	20	67.5	355	-/-	1855	105	430	485
355LX4-8	630	760	800	254	35	760	980	100	M20X42	210	28	86	355	-/-	1950	105	430	485
400 2	710	840	900	280	35	840	1060	85	M24X50	170	22	76	400	-/-	1910	147	430	485
400 4-8	710	840	900	280	35	840	1060	120	M24X50	210	32	109	400	-/-	1990	147	430	485
450 2	800	990	1000	250	42	990	1390	95	M24X50	170	25	86	450	-/-	2120	190	460	530
450 4-8	800	990	1000	250	42	990	1390	130	M24X50	210	32	119	450	-/-	2160	190	460	530

Datele tehnice si performantele se pot modifica / Technical data and performances may change

6T1 7T1 IE1 trifazat / *three-phase motor*

56-132 B5

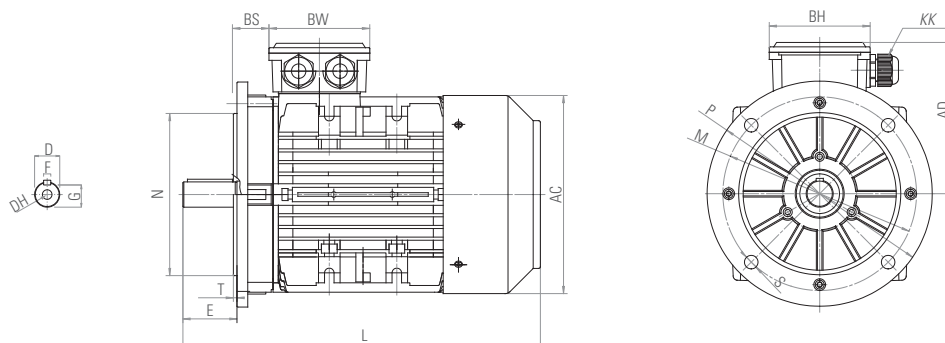

160-280 B5

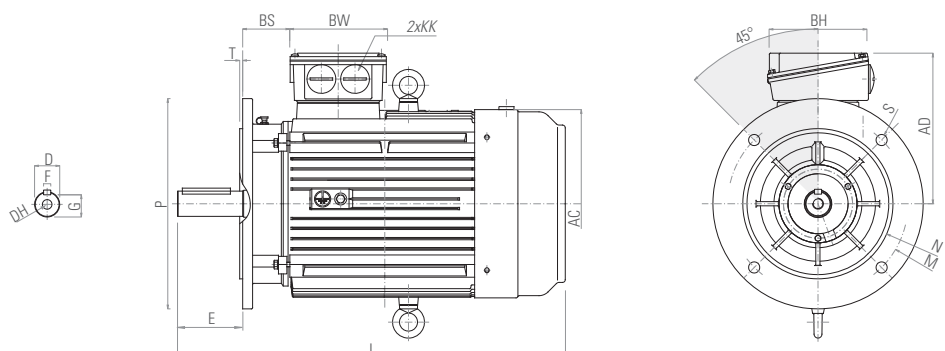

315-355 B5

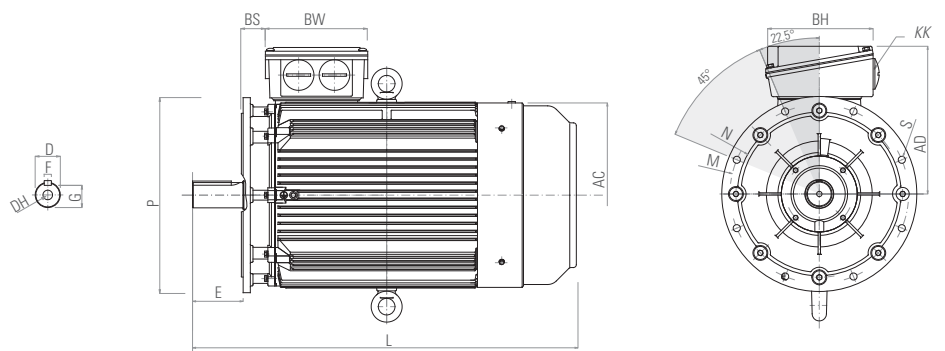

355LX-450 B5

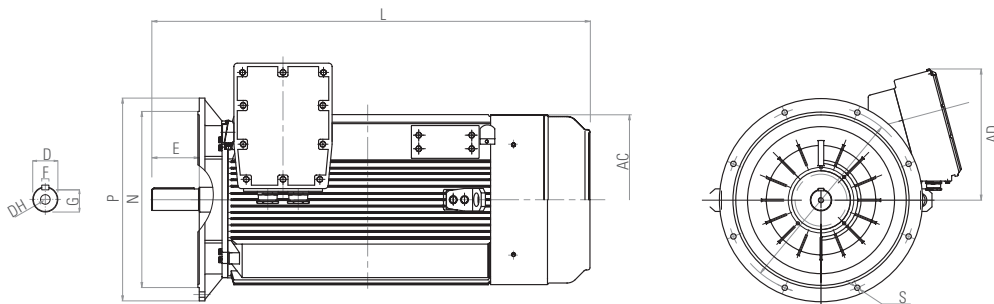

B5	P	M	N	S	T	AC	AD	D	DH	E	F	G	H	KK	L	BS	BW	BH
56-132 B5																		
56	120	100	80	7	3	115	97	9	M3X8	20	3	7.2	56	M16X1.5	195	14	88	88
63	140	115	95	10	3	130	105	11	M4X10	23	4	8.5	63	M16X1.5	215	14	94	94
71	160	130	110	10	3.5	145	112	14	M5X12	30	5	11	71	M20X1.5	255	20	94	94
80	200	165	130	12	3.5	165	130	19	M6X16	40	6	15.5	80	M20X1.5	277	27	105	105
90S	200	165	130	12	3.5	185	140	24	M8X20	50	8	20	90	M20X1.5	312	26	105	105
90L	200	165	130	12	3.5	185	140	24	M8X20	50	8	20	90	M20X1.5	337	26	105	105
100L	250	215	180	15	4	205	155	28	M10X22	60	8	24	100	M20X1.5	375	26	105	105
112	250	215	180	15	4	230	166	28	M10X22	60	8	24	112	M25X1.5	400	34	112	112
132S	300	265	230	15	4	270	188	38	M12X28	80	10	33	132	M25X1.5	460	40	112	112
132M	300	265	230	15	4	270	188	38	M12X28	80	10	33	132	M25X1.5	500	40	112	112
160-280 B5																		
160M	350	300	250	18.5	5	330	265	42	M16X36	110	12	37	160	M32X1.5	605	92	150	180
160L	350	300	250	18.5	5	330	265	42	M16X36	110	12	37	160	M32X1.5	650	92	150	180
180M	350	300	250	18.5	5	380	280	48	M16X36	110	14	42.5	180	M32X1.5	675	92	150	180
180L	350	300	250	18.5	5	380	280	48	M16X36	110	14	42.5	180	M32X1.5	715	92	150	180
200L	400	350	300	18.5	5	420	315	55	M20X42	110	16	49	200	M40X1.5	765	100	180	215
225S4	450	400	350	18.5	5	465	335	60	M20X42	140	18	53	225	M40X1.5	820	100	180	215
225M2	450	400	350	18.5	5	465	335	55	M20X42	110	16	49	225	M40X1.5	815	100	180	215
225M4-8	450	400	350	18.5	5	465	335	60	M20X42	140	18	53	225	M40X1.5	845	100	180	215
250M2	550	500	450	18.5	5	520	375	60	M20X42	140	18	53	250	M50X1.5	930	105	215	260
250M4-8	550	500	450	18.5	5	520	375	65	M20X42	140	18	58	250	M50X1.5	930	105	215	260
280S2	550	500	450	18.5	5	570	405	65	M20X42	140	18	58	280	M50X1.5	960	105	215	260
280S4-8	550	500	450	18.5	5	570	405	75	M20X42	140	20	67.5	280	M50X1.5	975	105	215	260
280M2	550	500	450	18.5	5	570	405	65	M20X42	140	18	58	280	M50X1.5	1000	105	215	260
280M4-8	550	500	450	18.5	5	570	405	75	M20X42	140	20	67.5	280	M50X1.5	1015	105	215	260
315-355 B5																		
315S2	660	600	550	24	6	620	500	65	M20X42	140	18	58	315	M63X1.5	1150	105	285	330
315S4-8	660	600	550	24	6	620	500	80	M20X42	170	22	71	315	M63X1.5	1185	105	285	330
315M2	660	600	550	24	6	620	500	65	M20X42	140	18	58	315	M63X1.5	1260	105	285	330
315M4-8	660	600	550	24	6	620	500	80	M20X42	170	22	71	315	M63X1.5	1295	105	285	330
315L2	660	600	550	24	6	620	500	65	M20X42	140	18	58	315	M63X1.5	1265	105	285	330
315L4-8	660	600	550	24	6	620	500	80	M20X42	170	22	71	315	M63X1.5	1305	105	285	330
355M2	800	740	680	24	6	700	645	75	M24X50	140	20	67.5	355	M63X1.5	1510	100	360	410
355M4-8	800	740	680	24	6	700	645	100	M24X50	210	28	86	355	M63X1.5	1640	100	360	410
355L2	800	740	680	24	6	700	645	75	M24X50	140	20	67.5	355	M63X1.5	1610	100	360	410
355L4-8	800	740	680	24	6	700	645	100	M24X50	210	28	86	355	M63X1.5	1640	100	360	410
355LX-450 B5																		
355LX2	900	840	780	24	6	760	625	75	M20X42	140	20	67.5	355	-/-	1855	105	430	485
355LX4-8	900	840	780	24	6	760	625	100	M20X42	210	28	86	355	-/-	1950	105	430	485
400 2	1000	940	880	28	6	840	660	85	M24X50	170	22	76	400	-/-	1910	147	430	485
400 4-8	1000	940	880	28	6	840	660	120	M24X50	210	32	109	400	-/-	1990	147	430	485
450 2	1150	1080	1000	28	6	1000	940	95	M24X50	170	25	86	450	-/-	2120	190	460	530
450 4-8	1150	1080	1000	28	6	1000	940	130	M24X50	210	32	119	450	-/-	2160	190	460	530

Nota: de la MEC225 inclus incolo, flansa B5 are 8 orificii de montare. Datele tehnice si performantele pot fi modificate
 Note: from MEC225 included onwards, the B5 flange has 8 mounting holes. Technical data and performances may change

6T1 7T1 IE1 trifazat / *three-phase motor*

56÷160

56-132 B14

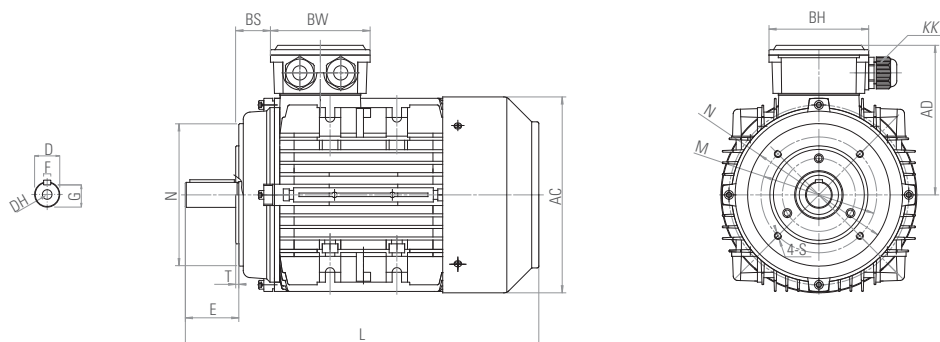

160 B14

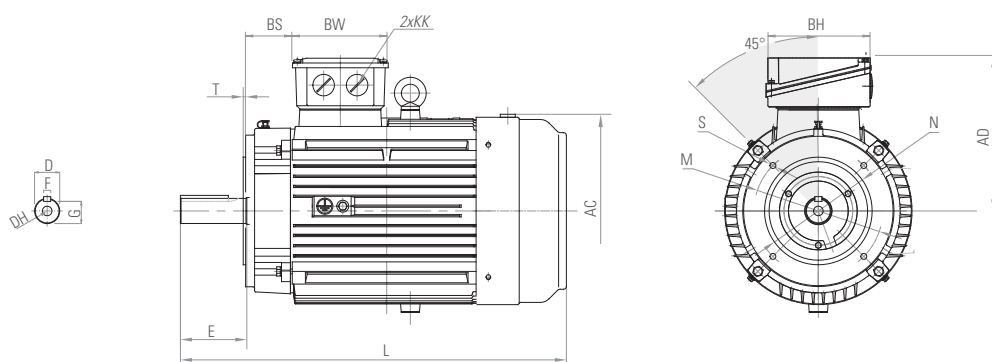

B14

	P	M	N	S	T	AC	AD	D	DH	E	F	G	H	KK	L	BS	BW	BH
56-132 B14																		
56	80	65	50	M5	2.5	115	97	9	M3X8	20	3	7.2	56	M16X1.5	195	14	88	88
63	90	75	60	M5	2.5	130	105	11	M4X10	23	4	8.5	63	M16X1.5	215	14	94	94
71	105	85	70	M6	2.5	145	112	14	M5X12	30	5	11	71	M20X1.5	255	20	94	94
80	120	100	80	M6	3	165	130	19	M6X16	40	40	15.5	80	M20X1.5	277	27	105	105
90S	140	115	95	M8	3	185	140	24	M8X20	50	50	20	90	M20X1.5	312	26	105	105
90L	140	115	95	M8	3	185	140	24	M8X20	50	50	20	90	M20X1.5	337	26	105	105
100L	160	130	110	M8	3.5	205	155	28	M10X22	60	60	24	100	M20X1.5	375	26	105	105
112	160	130	110	M8	3.5	230	166	28	M10X22	60	60	24	112	M25X1.5	400	34	112	112
132S	200	165	130	M10	3.5	270	188	38	M12X28	80	80	33	132	M25X1.5	460	40	112	112
132M	200	165	130	M10	3.5	270	188	38	M12X28	80	80	33	132	M25X1.5	500	40	112	112
160 B14																		
160M	250	215	180	M12	4	330	265	42	M16X36	110	12	37	160	M32X1.5	605	92	150	180
160L	250	215	180	M12	4	330	265	42	M16X36	110	12	37	160	M32X1.5	650	92	150	180

Nota: pana la MEC71 inclus, flansa standard B14 are 8 gauri de montare. Datele tehnice si performantele pot fi modificate
 Note: up to MEC71 included, the standard B14 flange has 8 mounting holes. Technical data and performances may change

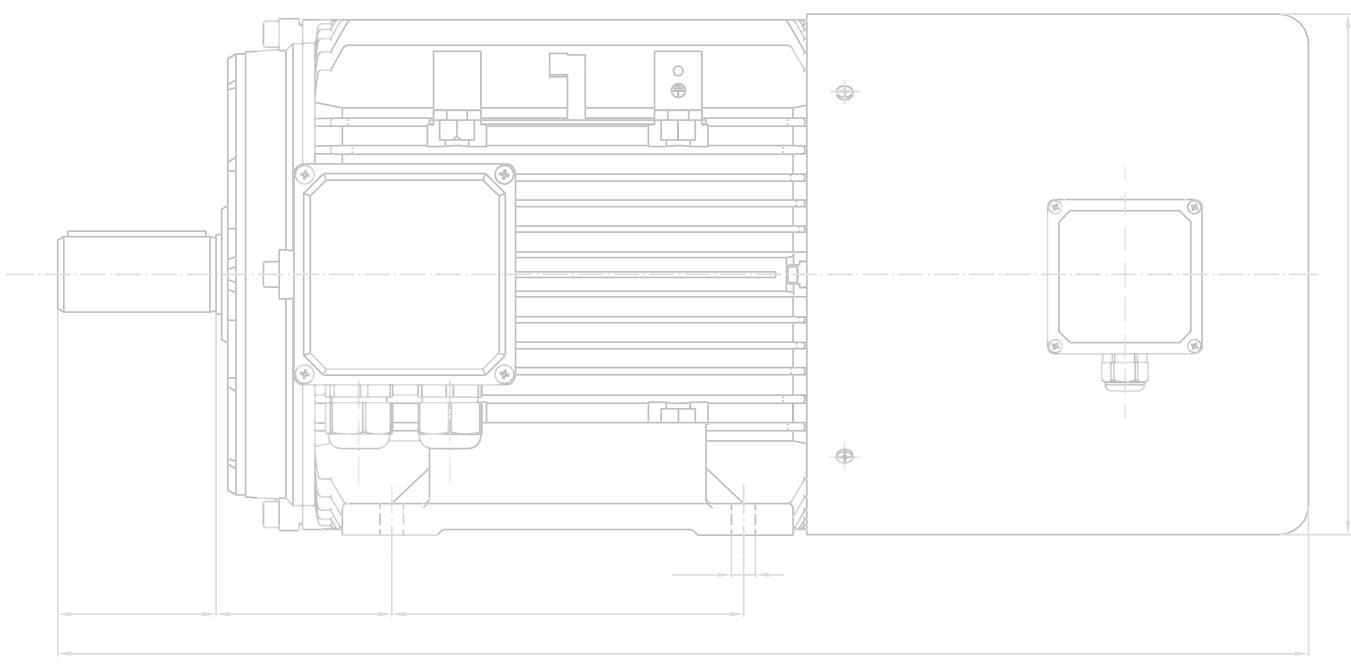
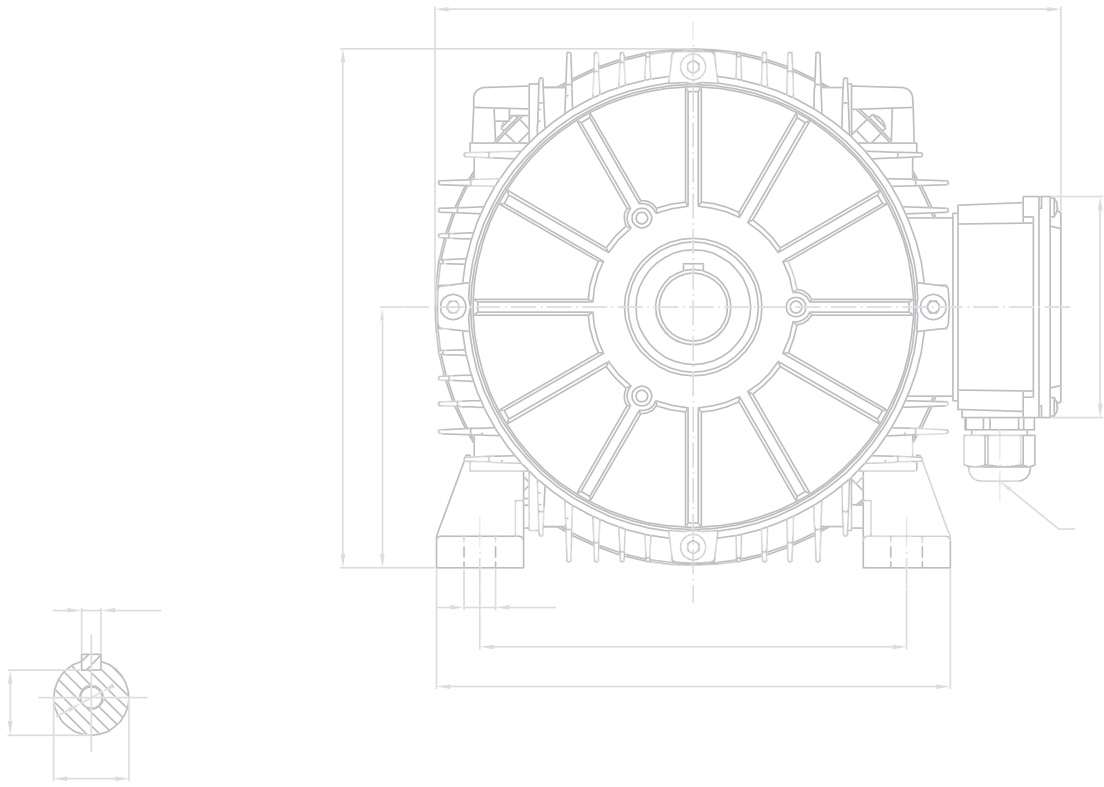

◆ 8.4 6P 6V / 7P 7V dubla polaritate / double polarity motor

71-132 B3

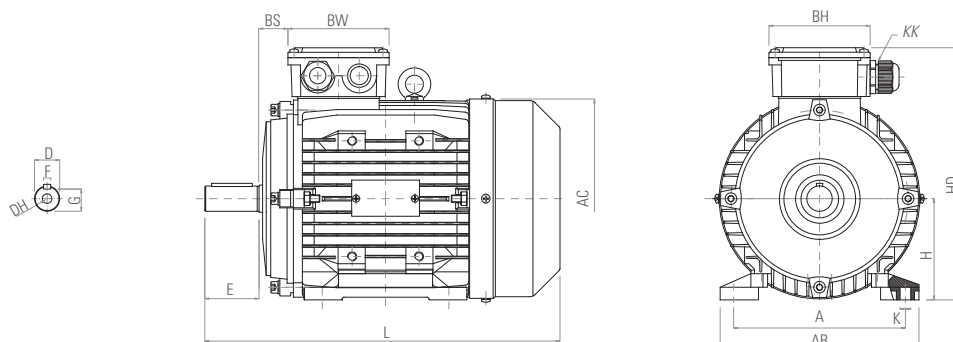

160-280 B3

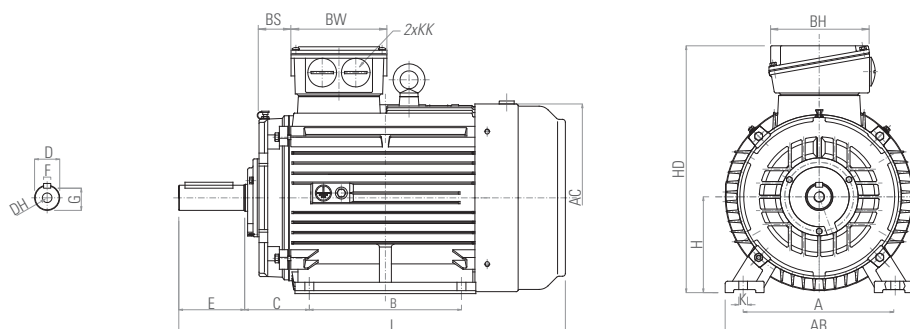

B3																		
	A	AB	B	C	K	AC	HD	D	DH	E	F	G	H	KK	L	BS	BW	BH
71-132 B3																		
71	112	132	90	45	7X10	145	183	14	M5X12	30	5	11	71	M20X1.5	255	20	94	94
80	125	160	100	50	10X10	165	212	19	M6X16	40	6	15.5	80	M20X1.5	290	27	105	105
90S	140	175	100	56	10X13	185	230	24	M8X20	50	8	20	90	M20X1.5	312	30	105	105
90L	140	175	125	56	10X13	185	230	24	M8X20	50	8	20	90	M20X1.5	337	30	105	105
100L	160	196	140	63	12X16	205	250	28	M10X22	60	8	24	100	M20X1.5	365	26	105	105
112	190	220	140	70	12X16	230	286	28	M10X22	60	8	24	112	M25X1.5	387	32	112	112
132S	216	252	140	89	12X16	270	319	38	M12X28	80	10	33	132	M25X1.5	436	38	112	112
132M	216	252	178	89	12X16	270	319	38	M12X28	80	10	33	132	M25X1.5	475	38	112	112
160-280 B3																		
160M	254	320	210	108	14X19	330	425	42	M16X36	110	12	37	160	M32X1.5	605	92	150	180
160L	254	320	254	108	14X19	330	425	42	M16X36	110	12	37	160	M32X1.5	650	92	150	180
180M	279	350	241	121	14X19	380	460	48	M16X36	110	14	42.5	180	M32X1.5	675	92	150	180
180L	279	350	279	121	14X19	380	460	48	M16X36	110	14	42.5	180	M32X1.5	715	92	150	180
200L	318	395	305	133	18X25	420	515	55	M20X42	110	16	49	200	M40X1.5	765	100	180	215
225S	356	436	286	149	18X25	465	560	60	M20X42	140	18	53	225	M40X1.5	820	100	180	215
225M	356	436	311	149	18X25	465	560	60	M20X42	140	18	53	225	M40X1.5	845	100	180	215
250M	406	495	349	168	24X33	520	625	65	M20X42	140	18	58	250	M50X1.5	930	105	215	260
280S	457	550	368	190	24X33	570	685	75	M20X42	140	20	67.5	280	M50X1.5	975	105	215	260
280M	457	550	419	190	24X33	570	685	75	M20X42	140	20	67.5	280	M50X1.5	1015	105	215	260

Datele tehnice si performantele se pot modifica / Technical data and performances may change

71-132 B5

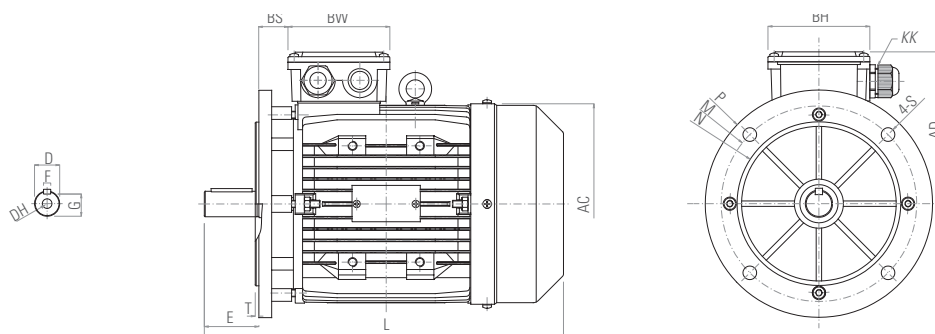

160-280 B5

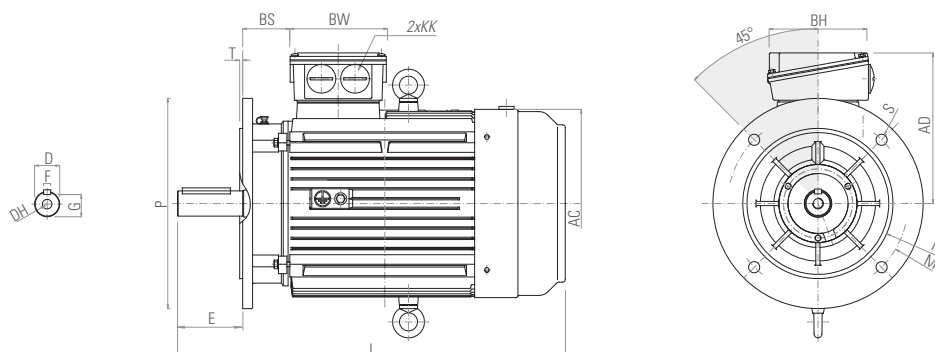

B5																		
	P	M	N	S	T	AC	AD	D	DH	E	F	G	H	KK	L	BS	BW	BH
71-132 B5																		
71	160	130	110	10	3.5	145	112	14	M5X12	30	5	11	71	M20X1.5	255	20	94	94
80	200	165	130	12	3.5	165	132	19	M6X16	40	6	15.5	80	M20X1.5	290	27	105	105
90S	200	165	130	12	3.5	185	140	24	M8X20	50	8	20	90	M20X1.5	312	30	105	105
90L	200	165	130	12	3.5	185	140	24	M8X20	50	8	20	90	M20X1.5	337	30	105	105
100L	250	215	180	15	4	205	150	28	M10X22	60	8	24	100	M20X1.5	365	26	105	105
112	250	215	180	15	4	230	174	28	M10X22	60	8	24	112	M25X1.5	387	32	112	112
132S	300	265	230	15	4	270	187	38	M12X28	80	10	33	132	M25X1.5	436	38	112	112
132M	300	265	230	15	4	270	187	38	M12X28	80	10	33	132	M25X1.5	475	38	112	112
160-280 B5																		
160M	350	300	250	18.5	5	330	265	42	M16X36	110	12	37	160	M32X1.5	605	92	150	180
160L	350	300	250	18.5	5	330	265	42	M16X36	110	12	37	160	M32X1.5	650	92	150	180
180M	350	300	250	18.5	5	380	280	48	M16X36	110	14	42.5	180	M32X1.5	675	92	150	180
180L	350	300	250	18.5	5	380	280	48	M16X36	110	14	42.5	180	M32X1.5	715	92	150	180
200L	400	350	300	18.5	5	420	315	55	M20X42	110	16	49	200	M40X1.5	765	100	180	215
225S	450	400	350	18.5	5	465	335	60	M20X42	140	18	53	225	M40X1.5	820	100	180	215
225M	450	400	350	18.5	5	465	335	60	M20X42	140	18	53	225	M40X1.5	845	100	180	215
250M	550	500	450	18.5	5	520	375	65	M20X42	140	18	58	250	M50X1.5	930	105	215	260
280S	550	500	450	18.5	5	570	405	75	M20X42	140	20	67.5	280	M50X1.5	975	105	215	260
280M	550	500	450	18.5	5	570	405	75	M20X42	140	20	67.5	280	M50X1.5	1015	105	215	260

Nota: de la MEC225 inclus incolo, flansa B5 are 8 orificii de montare
Datele tehnice si performantele se pot modifica

Nota: from MEC225 included onwards, the B5 flange has 8 mounting holes
Technical data and performances may change

6P 6V / 7P 7V dubla polaritate / *double polarity motor*

71÷160

71-132 B14

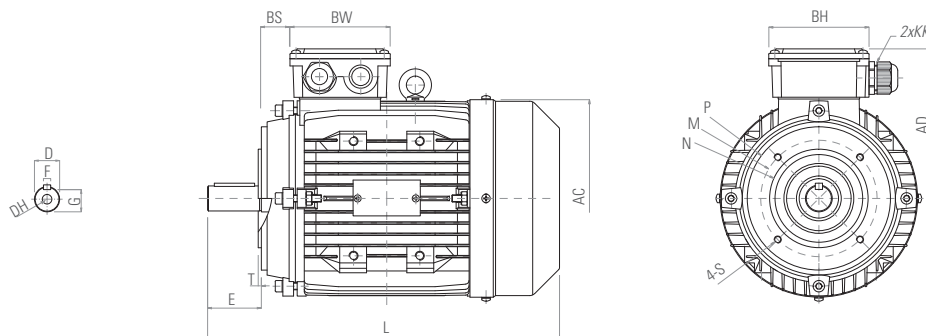

160 B14

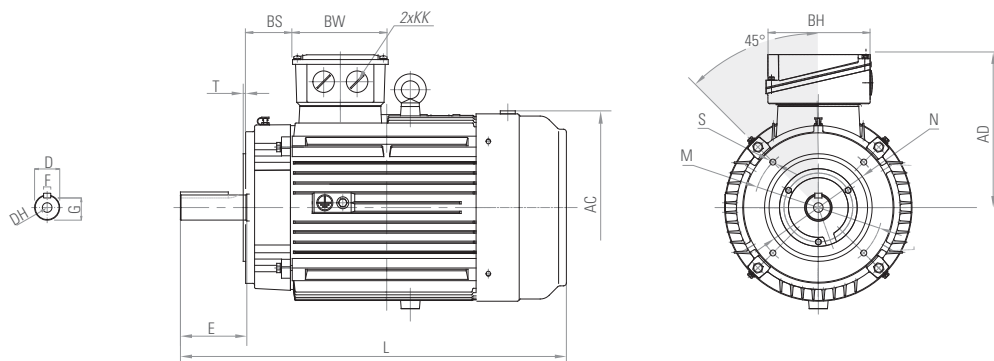

B14

	P	M	N	S	T	AC	HD	D	DH	E	F	G	H	KK	L	BS	BW	BH
71-132 B14																		
71	105	85	70	M6	2.5	145	112	14	M5X12	30	5	11	71	M20X1.5	255	20	94	94
80	120	100	80	M6	3	165	132	19	M6X16	40	6	15.5	80	M20X1.5	290	27	105	105
90S	140	115	95	M8	3	185	140	24	M8X20	50	8	20	90	M20X1.5	312	30	105	105
90L	140	115	95	M8	3	185	140	24	M8X20	50	8	20	90	M20X1.5	337	30	105	105
100L	160	130	110	M8	3.5	205	150	28	M10X22	60	8	24	100	M20X1.5	365	26	105	105
112	160	130	110	M8	3.5	230	174	28	M10X22	60	8	24	112	M25X1.5	387	32	112	112
132S	200	165	130	M10	3.5	270	187	38	M12X28	80	10	33	132	M25X1.5	436	38	112	112
132M	200	165	130	M10	3.5	270	187	38	M12X28	80	10	33	132	M25X1.5	475	38	112	112
160 B14																		
160M	250	215	180	M12	4	330	265	42	M16X36	110	12	37	160	M32X1.5	605	92	150	180
160L	250	215	180	M12	4	330	265	42	M16X36	110	12	37	160	M32X1.5	650	92	150	180

Nota: pana la MEC71 inclus, flansa standard B14 are 8 gauri de montare.
Datele tehnice si performantele pot fi modificate.

Note: up to MEC71 included, the standard B14 flange has 8 mounting holes.
Technical data and performances may change

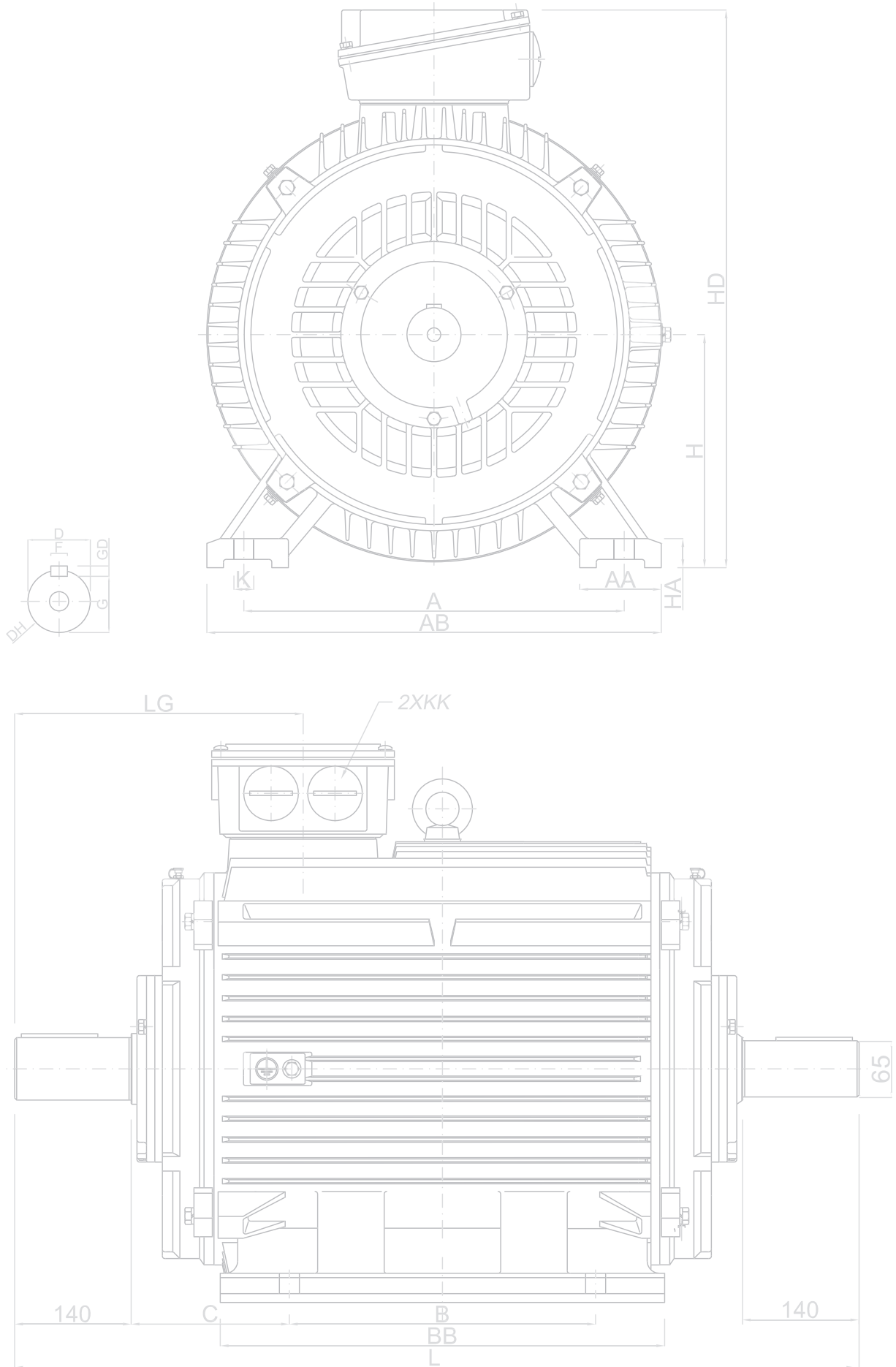

◆ 8.5 6M 6L motor monofazat / *single-phase motor*

56-112 B3

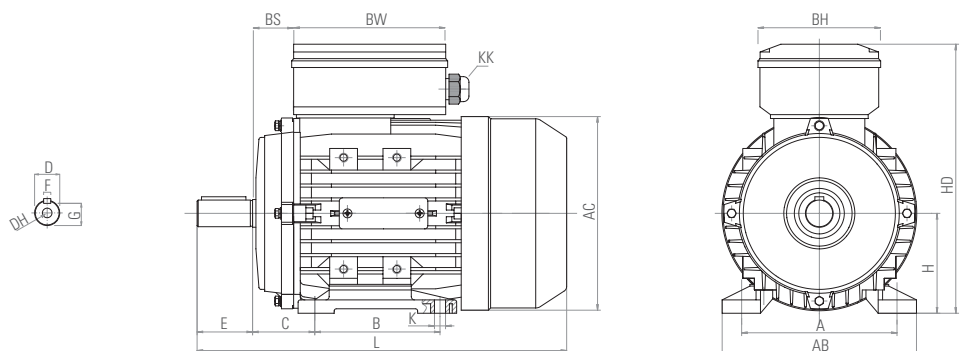

B3

	A	AB	B	C	K	AC	HD	D	DH	E	F	G	H	KK	L	BS	BW	BH	
56-100 B3 ▶ 6M																			
56	90	108	71	36	5.8X8.8	115	156	9	M3X8	20	3	7.2	56	M16X1.5	192	14	116	92	
63	100	120	80	40	7X10	130	179	11	M4X10	23	4	8.5	63	M16X1.5	212	14	116	92	
71	112	132	90	45	7X10	145	194	14	M5X12	30	5	11	71	M20X1.5	240	20	116	92	
80	125	157	100	50	10X10	165	223	19	M6X16	40	6	15.5	80	M20X1.5	290	27	141	111	
90S	140	172	100	56	10X13	185	240	24	M8X20	50	8	20	90	M20X1.5	310	30	141	111	
90L	140	172	125	56	10X13	185	240	24	M8X20	50	8	20	90	M20X1.5	335	30	141	111	
100	160	196	140	63	12X15	205	260	28	M10X22	60	8	24	100	M20X1.5	357	26	141	111	
63-112 B3 ▶ 6L																			
63	100	120	80	40	7X10	130	179	11	M4X10	23	4	8.5	63	M16X1.5	212	14	104	144	
71	112	132	90	45	7X10	145	194	14	M5X12	30	5	11	71	M20X1.5	255	20	104	144	
80	125	157	100	50	10X10	165	223	19	M6X16	40	6	15.5	80	M20X1.5	290	27	149	173	
90S	140	172	100	56	10X13	185	240	24	M8X20	50	8	20	90	M20X1.5	335	30	149	173	
90L	140	172	125	56	10X13	185	240	24	M8X20	50	8	20	90	M20X1.5	365	30	149	173	
100	160	196	140	63	12X15	205	260	28	M10X22	60	8	24	100	M20X1.5	445	26	150	193	
112	190	222	140	70	12X15	230	295	28	M10X22	60	8	24	112	M25X1.5	453	32	150	193	

56-112 B5

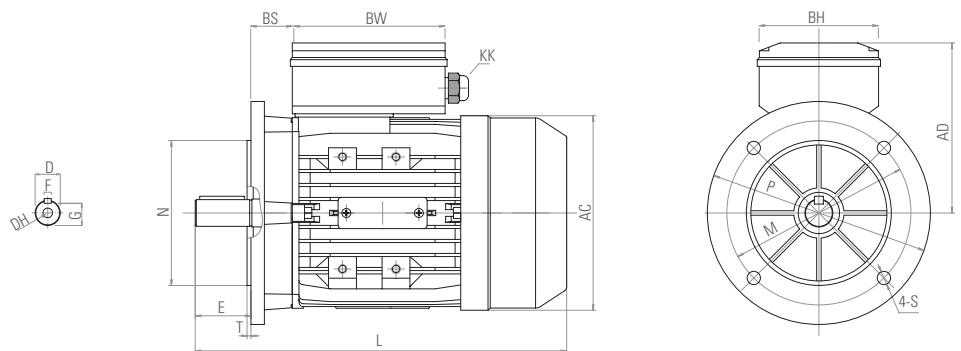

B5

	P	M	N	S	T	AC	AD	D	DH	E	F	G	H	KK	L	BS	BW	BH	
56-100 B5 ▶ 6M																			
56	120	98	80	7	3	115	100	9	M3X8	20	3	7.2	56	M16X1.5	192	14	116	92	
63	140	115	95	10	3	130	116	11	M4X10	23	4	8.5	63	M16X1.5	212	14	116	92	
71	160	130	110	10	3.5	145	123	14	M5X12	30	5	11	71	M20X1.5	240	20	116	92	
80	200	165	130	12	3.5	165	143	19	M6X16	40	6	15.5	80	M20X1.5	290	27	141	111	
90S	200	165	130	12	3.5	185	150	24	M8X20	50	8	20	90	M20X1.5	310	30	141	111	
90L	200	165	130	12	3.5	185	150	24	M8X20	50	8	20	90	M20X1.5	335	30	141	111	
100	250	215	180	15	4	205	160	28	M10X22	60	8	24	100	M20X1.5	357	26	141	111	
63-112 B5 ▶ 6L																			
63	140	115	95	10	3	130	116	11	M4X10	23	4	8.5	63	M16X1.5	212	14	104	144	
71	160	130	110	10	3.5	145	123	14	M5X12	30	5	11	71	M20X1.5	255	20	104	144	
80	200	165	130	12	3.5	165	143	19	M6X16	40	6	15.5	80	M20X1.5	290	27	149	173	
90S	200	165	130	12	3.5	185	150	24	M8X20	50	8	20	90	M20X1.5	335	30	149	173	
90L	200	165	130	12	3.5	185	150	24	M8X20	50	8	20	90	M20X1.5	365	30	149	173	
100	250	215	180	15	4	205	160	28	M10X22	60	8	24	100	M20X1.5	445	26	150	193	
112	250	215	180	15	4	230	183	28	M10X22	60	8	24	112	M25X1.5	453	32	150	193	

56-112 B14

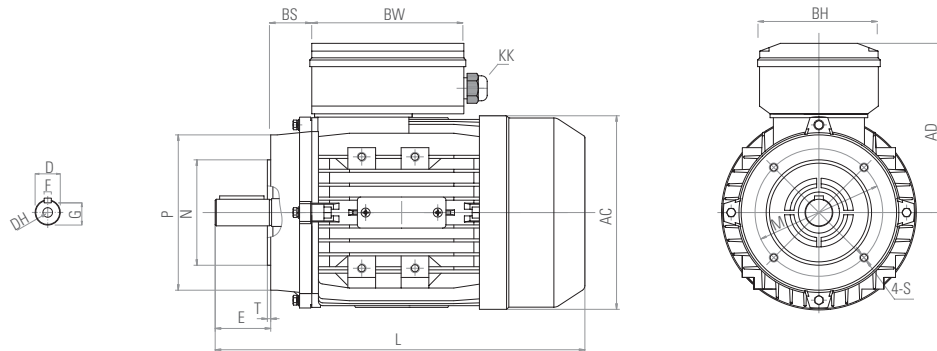

B14

	P	M	N	S	T	AC	AD	D	DH	E	F	G	H	KK	L	BS	BW	BH
56-100 B14 ▶ 6M																		
56	80	65	50	M5	2.5	115	100	9	M3X8	20	3	7.2	56	M16X1.5	192	14	116	92
63	90	75	60	M5	2.5	130	116	11	M4X10	23	4	8.5	63	M16X1.5	212	14	116	92
71	105	85	70	M6	2.5	145	123	14	M5X12	30	5	11	71	M20X1.5	240	20	116	92
80	120	100	80	M6	3	165	143	19	M6X16	40	6	15.5	80	M20X1.5	290	27	141	111
90S	140	115	95	M8	3	185	150	24	M8X20	50	8	20	90	M20X1.5	310	30	141	111
90L	140	115	95	M8	3	185	150	24	M8X20	50	8	20	90	M20X1.5	335	30	141	111
100	160	130	110	M8	3.5	205	160	28	M10X22	60	8	24	100	M20X1.5	357	26	141	111
63-112 B14 ▶ 6L																		
63	90	75	60	M5	2.5	130	116	11	M4X10	23	4	8.5	63	M16X1.5	212	14	104	144
71	105	85	70	M6	2.5	145	123	14	M5X12	30	5	11	71	M20X1.5	255	20	104	144
80	120	100	80	M6	3	165	143	19	M6X16	40	6	15.5	80	M20X1.5	290	27	149	173
90S	140	115	95	M8	3	185	150	24	M8X20	50	8	20	90	M20X1.5	335	30	149	173
90L	140	115	95	M8	3	185	150	24	M8X20	50	8	20	90	M20X1.5	365	30	149	173
100	160	130	110	M8	3.5	205	160	28	M10X22	60	8	24	100	M20X1.5	445	26	150	193
112	160	130	110	M8	3.5	230	183	28	M10X22	60	8	24	112	M25X1.5	453	32	150	193

Nota: pana la MEC71 inclus, flansa standard B14 are 8 gauri de montare

Note: up to MEC71 included, the standard B14 flange has 8 mounting holes

Datele tehnice si performantele se pot modifica / Technical data and performances may change

◆ 8.6 6TC 6TK / 7TC 7TK cuplu ridicat, motor cu frana / *high torque, brake motor*

56-132 B3

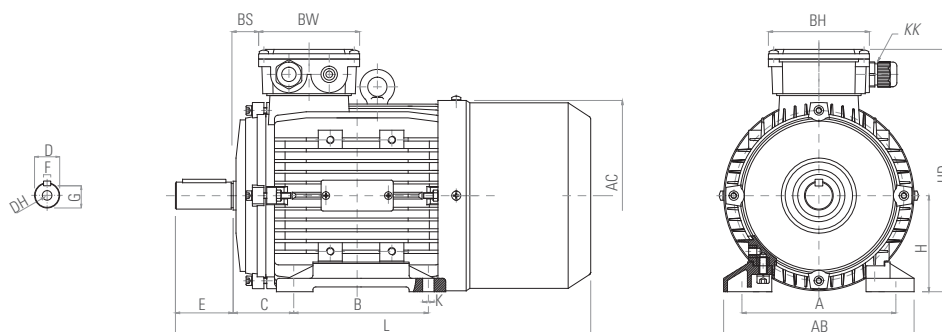

160-280 B3

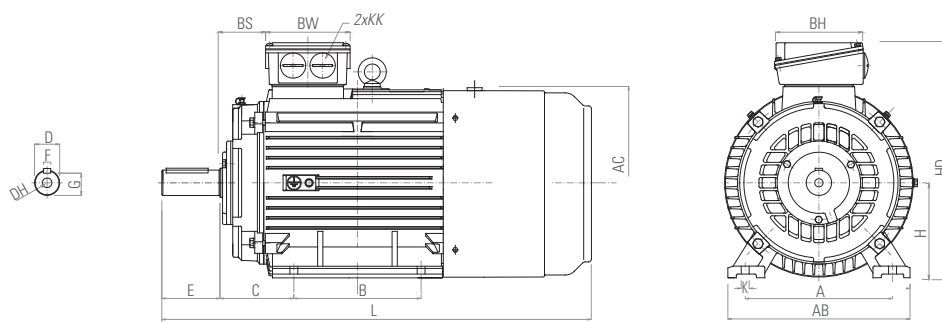

B3

	A	AB	B	C	K	AC	HD	D	DH	E	F	G	H	KK	L	BS	BW	BH
56-132 B3																		
56	90	110	71	36	5.8X8.8	115	153	9	M3X8	20	3	7.2	56	M20X1.5	240	14	88	88
63	100	120	80	40	7X10	130	168	11	M4X10	23	4	8.5	63	M20X1.5	270	14	94	94
71	112	132	90	45	7X10	145	183	14	M5X12	30	5	11	71	M20X1.5	310	20	94	94
80	125	160	100	50	10X10	165	212	19	M6X16	40	6	15.5	80	M20X1.5	345	27	105	105
90S	140	175	100	56	10X13	185	230	24	M8X20	50	8	20	90	M20X1.5	370	30	105	105
90L	140	175	125	56	10X13	185	230	24	M8X20	50	8	20	90	M20X1.5	395	30	105	105
90LB	140	175	125	56	10X13	185	230	24	M8X20	50	8	20	90	M20X1.5	425	30	105	105
100L	160	196	140	63	12X16	205	250	28	M10X22	60	8	24	100	M20X1.5	460	26	105	105
100LC	160	196	140	63	12X16	205	250	28	M10X22	60	8	24	100	M20X1.5	480	26	105	105
112	190	220	140	70	12X16	230	286	28	M10X22	60	8	24	112	M25X1.5	490	32	112	112
132S	216	252	140	89	12X16	270	319	38	M12X28	80	10	33	132	M25X1.5	530	38	112	112
132M	216	252	178	89	12X16	270	319	38	M12X28	80	10	33	132	M25X1.5	570	38	112	112
132MA-MB	216	252	178	89	12X16	270	319	38	M12X28	80	10	33	132	M25X1.5	600	38	112	112
160-280 B3																		
160M	254	320	210	108	14X19	330	425	42	M16X36	110	12	37	160	M32X1.5	740	92	150	180
160L	254	320	254	108	14X19	330	425	42	M16X36	110	12	37	160	M32X1.5	790	92	150	180
180M	279	350	241	121	14X19	380	460	48	M16X36	110	14	42.5	180	M32X1.5	800	92	150	180
180L	279	350	279	121	14X19	380	460	48	M16X36	110	14	42.5	180	M32X1.5	850	92	150	180
200L	318	395	305	133	18X25	420	515	55	M20X42	110	16	49	200	M40X1.5	880	100	180	215
225S4	356	436	286	149	18X25	465	560	60	M20X42	140	18	53	225	M40X1.5	930	100	180	215
225M2	356	436	311	149	18X25	465	560	55	M20X42	110	16	49	225	M40X1.5	960	100	180	215
225M4-8	356	436	311	149	18X25	465	560	60	M20X42	140	18	53	225	M40X1.5	960	100	180	215
250M2	406	495	349	168	24X33	520	625	60	M20X42	140	18	53	250	M50X1.5	1080	105	215	260
250M4-8	406	495	349	168	24X33	520	625	65	M20X42	140	18	58	250	M50X1.5	1080	105	215	260
280S2	457	550	368	190	24X33	570	685	65	M20X42	140	18	58	280	M50X1.5	1140	105	215	260
280S4-8	457	550	368	190	24X33	570	685	75	M20X42	140	20	67.5	280	M50X1.5	1160	105	215	260
280M2	457	550	419	190	24X33	570	685	65	M20X42	140	18	58	280	M50X1.5	1180	105	215	260
280M4-8	457	550	419	190	24X33	570	685	75	M20X42	140	20	67.5	280	M50X1.5	1200	105	215	260

Datele tehnice si performantele se pot modifica / Technical data and performances may change

56-132 B5

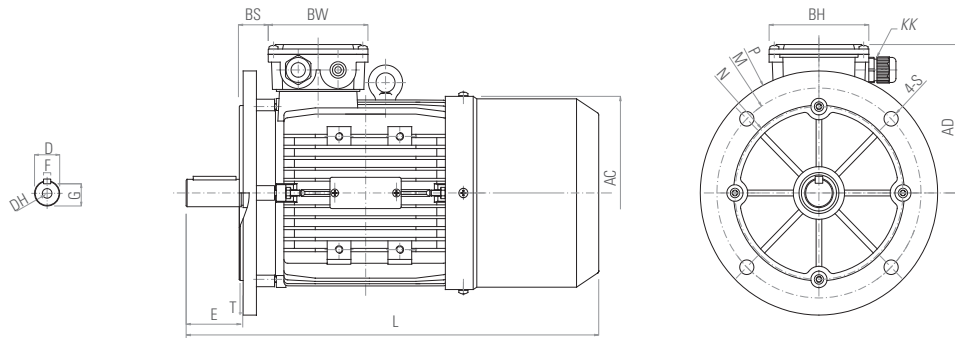

160-280 B5

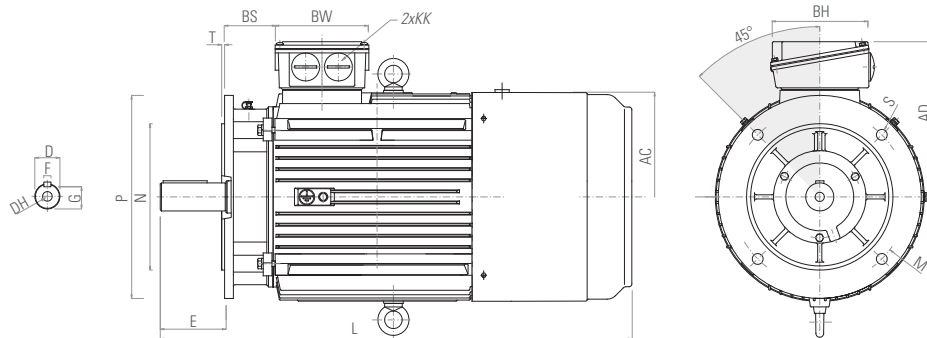

B5

	P	M	N	S	T	AC	HD	D	DH	E	F	G	H	KK	L	BS	BW	BH	
56-132 B5																			
56	120	100	80	7	3	115	97	9	M3X8	20	3	7.2	56	M20X1.5	240	14	88	88	
63	140	115	95	10	3	130	105	11	M4X10	23	4	8.5	63	M16X1.5	270	14	94	94	
71	160	130	110	10	3.5	145	112	14	M5X12	30	5	11	71	M20X1.5	310	20	94	94	
80	200	165	130	12	3.5	165	132	19	M6X16	40	6	15.5	80	M20X1.5	345	27	105	105	
90S	200	165	130	12	3.5	185	140	24	M8X20	50	8	20	90	M20X1.5	370	30	105	105	
90L	200	165	130	12	3.5	185	140	24	M8X20	50	8	20	90	M20X1.5	395	30	105	105	
90LB	200	165	130	12	3.5	185	140	24	M8X20	50	8	20	90	M20X1.5	425	30	105	105	
100L	250	215	180	15	4	205	150	28	M10X22	60	8	24	100	M20X1.5	460	26	105	105	
100LC	250	215	180	15	4	205	150	28	M10X22	60	8	24	100	M20X1.5	480	26	105	105	
112	250	215	180	15	4	230	174	28	M10X22	60	8	24	112	M25X1.5	490	32	112	112	
132S	300	265	230	15	4	270	187	38	M12X28	80	10	33	132	M25X1.5	530	38	112	112	
132M	300	265	230	15	4	270	187	38	M12X28	80	10	33	132	M25X1.5	570	38	112	112	
132MA-MB	300	265	230	15	4	270	187	38	M12X28	80	10	33	132	M25X1.5	600	38	112	112	
160-280 B5																			
160M	350	300	250	18.5	5	330	265	42	M16X36	110	12	37	160	M32X1.5	740	92	150	180	
160L	350	300	250	18.5	5	330	265	42	M16X36	110	12	37	160	M32X1.5	790	92	150	180	
180M	350	300	250	18.5	5	380	280	48	M16X36	110	14	42.5	180	M32X1.5	800	92	150	180	
180L	350	300	250	18.5	5	380	280	48	M16X36	110	14	42.5	180	M32X1.5	850	92	150	180	
200L	400	350	300	18.5	5	420	315	55	M20X42	110	16	49	200	M40X1.5	880	100	180	215	
225S4	450	400	350	18.5	5	465	335	60	M20X42	140	18	53	225	M40X1.5	930	100	180	215	
225M2	450	400	350	18.5	5	465	335	55	M20X42	110	16	49	225	M40X1.5	960	100	180	215	
225M4-8	450	400	350	18.5	5	465	335	60	M20X42	140	18	53	225	M40X1.5	960	100	180	215	
250M2	550	500	450	18.5	5	520	375	60	M20X42	140	18	53	250	M50X1.5	1080	105	215	260	
250M4-8	550	500	450	18.5	5	520	375	65	M20X42	140	18	58	250	M50X1.5	1080	105	215	260	
280S2	550	500	450	18.5	5	570	405	65	M20X42	140	18	58	280	M50X1.5	1140	105	215	260	
280S4-8	550	500	450	18.5	5	570	405	75	M20X42	140	20	67.5	280	M50X1.5	1160	105	215	260	
280M2	550	500	450	18.5	5	570	405	65	M20X42	140	18	58	280	M50X1.5	1180	105	215	260	
280M4-8	550	500	450	18.5	5	570	405	75	M20X42	140	20	67.5	280	M50X1.5	1200	105	215	260	

Nota: de la MEC225 inclus incolo, flansa B5 are 8 orificii de montare.
Datele tehnice si performantele pot fi modificate

Note: from MEC225 included onwards, the B5 flange has 8 mounting holes.
Technical data and performances may change

6TC 6TK / 7TC 7TK cuplu ridicat, motor cu frana / *high torque, brake motor* 56÷160

56-132 B14

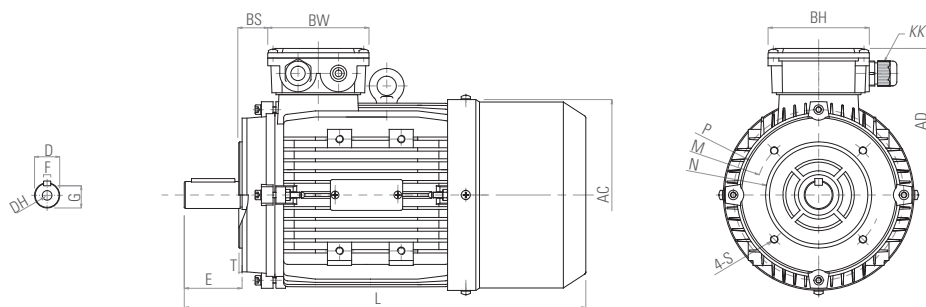

160 B14

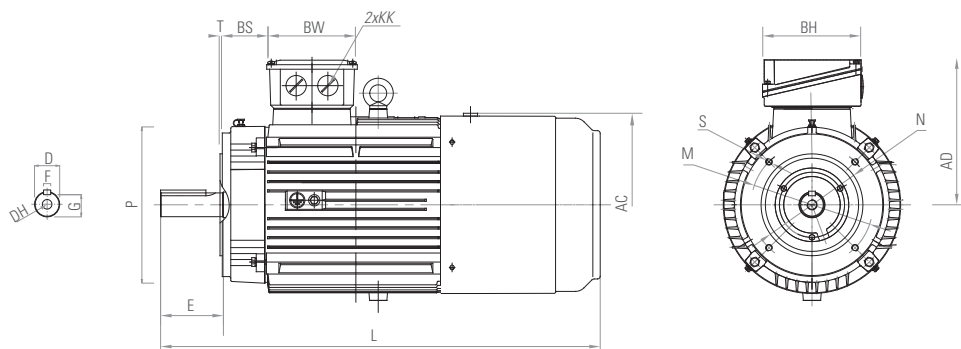

B14	P	M	N	S	T	AC	HD	D	DH	E	F	G	H	KK	L	BS	BW	BH
56-132 B14																		
56	80	65	50	M5	2.5	115	97	9	M3X8	20	3	7.2	56	M16X1.5	240	14	88	88
63	90	75	60	M5	2.5	130	105	11	M4X10	23	4	8.5	63	M16X1.5	270	14	94	94
71	105	85	70	M6	2.5	145	112	14	M5X12	30	5	11	71	M20X1.5	310	20	94	94
80	120	100	80	M6	3	165	132	19	M6X16	40	6	15.5	80	M20X1.5	345	27	105	105
90S	140	115	95	M8	3	185	140	24	M8X20	50	8	20	90	M20X1.5	370	30	105	105
90L	140	115	95	M8	3	185	140	24	M8X20	50	8	20	90	M20X1.5	395	30	105	105
90LB	140	115	95	M8	3	185	140	24	M8X20	50	8	20	90	M20X1.5	425	30	105	105
100L	160	130	110	M8	3.5	205	150	28	M10X22	60	8	24	100	M20X1.5	460	26	105	105
100LC	160	130	110	M8	3.5	205	150	28	M10X22	60	8	24	100	M20X1.5	480	26	105	105
112	160	130	110	M8	3.5	230	174	28	M10X22	60	8	24	112	M25X1.5	490	32	112	112
132S	200	165	130	M10	3.5	270	187	38	M12X28	80	10	33	132	M25X1.5	530	38	112	112
132M	200	165	130	M10	3.5	270	187	38	M12X28	80	10	33	132	M25X1.5	570	38	112	112
132MA-MB	200	165	130	M10	3.5	270	187	38	M12X28	80	10	33	132	M25X1.5	600	38	112	112
160 B14																		
160M	250	215	180	M12	4	330	265	42	M16X36	110	12	37	160	M32X1.5	740	92	150	180
160L	250	215	180	M12	4	330	265	42	M16X36	110	12	37	160	M32X1.5	790	92	150	180

Nota: pana la MEC71 inclus, flansa standard B14 are 8 gauri de montare.
Datele tehnice si performantele pot fi modificate

Note: up to MEC71 included, the standard B14 flange has 8 mounting holes.
Technical data and performances may change

Specificatii dimensionale motoare electrice cu frana

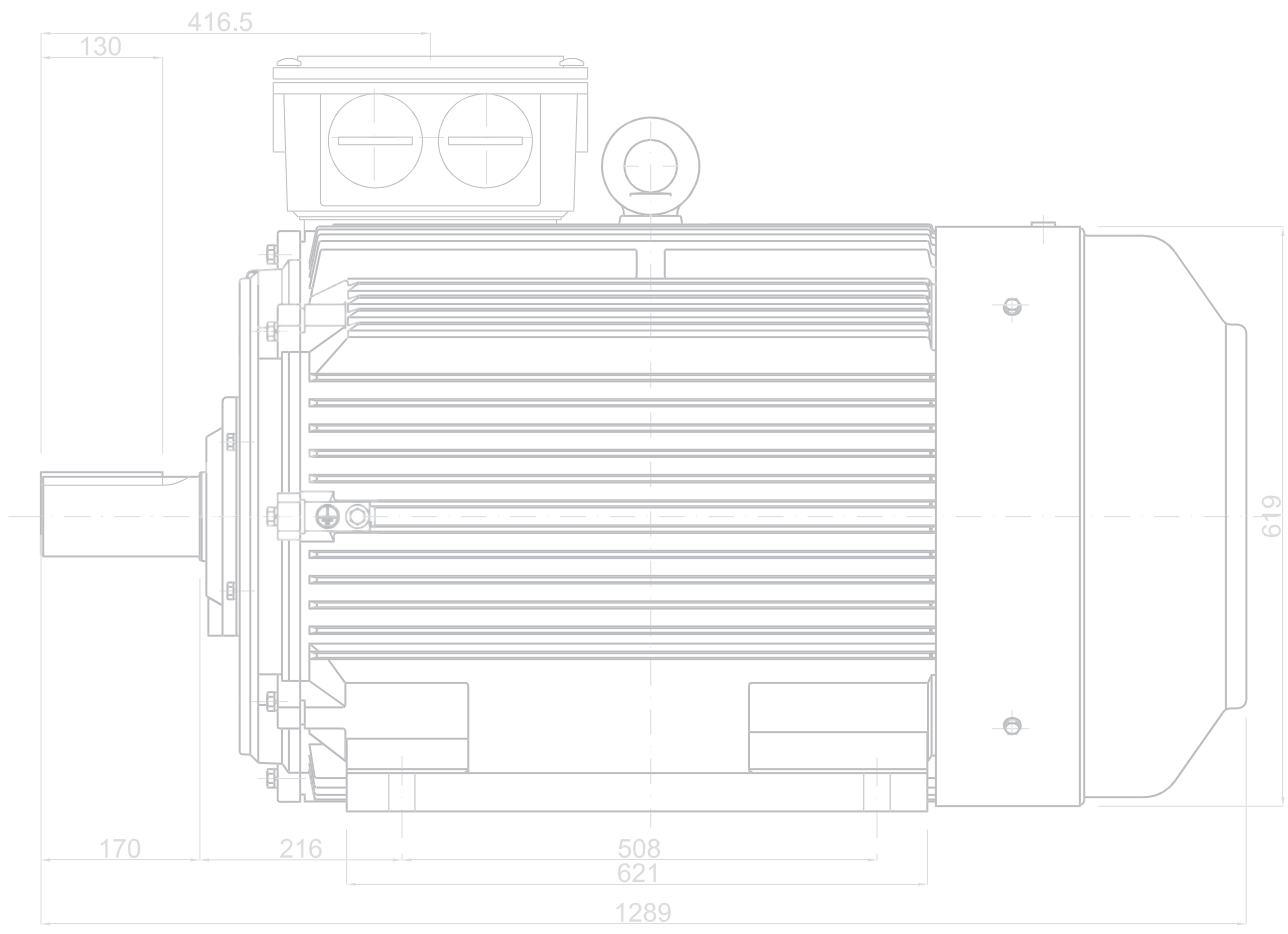
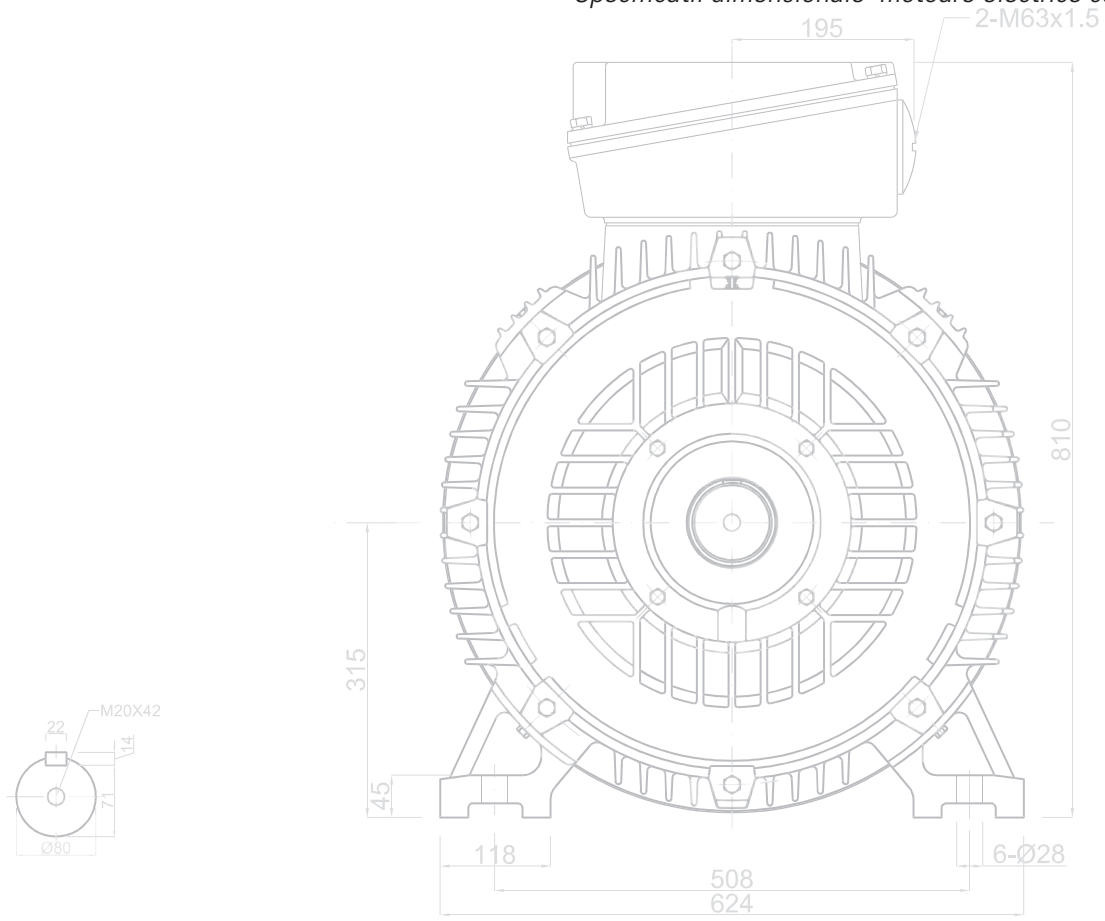

1TC 1TK cuplu ridicat, motor cu frana / high torque, brake motor

71-132 B3

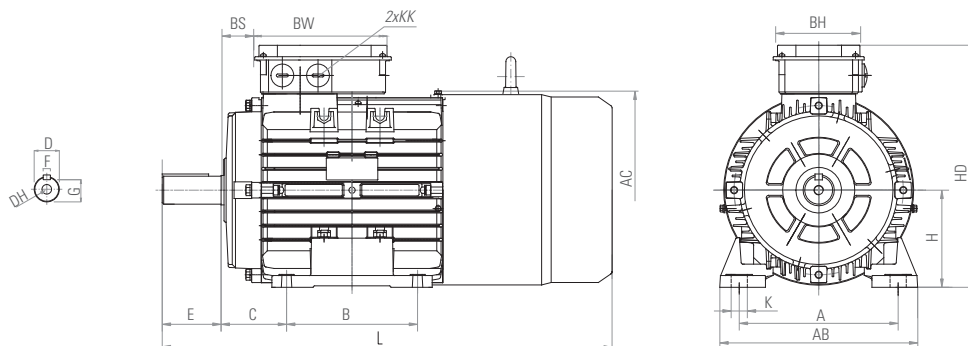

B3

	A	AB	B	C	K	AC	HD	D	DH	E	F	G	H	KK	L	BS	BW	BH	
71-132 B3																			
71	112	135	90	45	7X10	155	181	14	M5X12	30	5	11	71	M20X1.5	315	25	140	100	
80	125	165	100	50	10X10	175	205	19	M6X16	40	6	15.5	80	M25X1.5	355	25	155	115	
90S	140	180	100	56	10X13	190	225	24	M8X20	50	8	20	90	M25X1.5	400	30	155	115	
90L	140	180	125	56	10X13	190	225	24	M8X20	50	8	20	90	M25X1.5	425	30	155	115	
100L	160	200	140	63	12X16	206	255	28	M10X22	60	8	24	100	M25X1.5	470	38	155	115	
112	190	235	140	70	12X16	235	287	28	M10X22	60	8	24	112	M32X1.5	490	35	210	140	
132S	216	270	140	89	12X16	275	320	38	M12X28	80	10	33	132	M32X1.5	565	40	210	140	
132M	216	270	178	89	12X16	275	320	38	M12X28	80	10	33	132	M32X1.5	600	40	210	140	

Nota: Standard 1TC cu eliberare manuala.

Datele tehnice si performantele pot fi modificate

Nota: 1TC standard with hand release.

Technical data and performances may change

71-132 B5

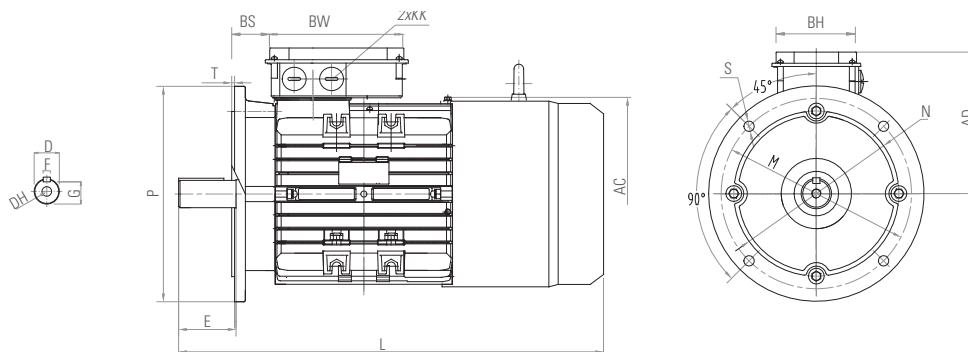

B5

	P	M	N	S	T	AC	AD	D	DH	E	F	G	H	KK	L	BS	BW	BH	
71-132 B5																			
71	160	130	110	10	3.5	155	110	14	M5X12	30	5	11	71	M20X1.5	315	25	140	100	
80	200	165	130	12	3.5	175	125	19	M6X16	40	6	15.5	80	M25X1.5	355	25	155	115	
90S	200	165	130	12	3.5	190	135	24	M8X20	50	8	20	90	M25X1.5	400	30	155	115	
90L	200	165	130	12	3.5	190	135	24	M8X20	50	8	20	90	M25X1.5	425	30	155	115	
100L	250	215	180	15	4	206	155	28	M10X22	60	8	24	100	M25X1.5	470	38	155	115	
112	250	215	180	15	4	235	175	28	M10X22	60	8	24	112	M32X1.5	490	35	210	140	
132S	300	265	230	15	4	275	188	38	M12X28	80	10	33	132	M32X1.5	565	40	210	140	
132M	300	265	230	15	4	275	188	38	M12X28	80	10	33	132	M32X1.5	600	40	210	140	

Nota: Standard 1TC cu eliberare manuala.

Datele tehnice si performantele pot fi modificate

Nota: 1TC standard with hand release.

Technical data and performances may change

71-132 B14

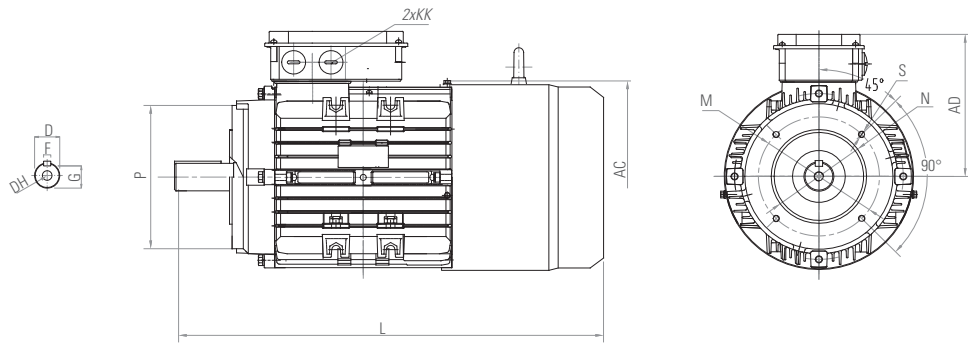

B3

	P	M	N	S	T	AC	AD	D	DH	E	F	G	H	KK	L	BS	BW	BH
71-132 B14																		
71	105	85	70	M6	2.5	155	110	14	M5X12	30	5	11	71	M20X1.5	315	25	140	100
80	120	100	80	M6	3	175	125	19	M6X16	40	6	15.5	80	M25X1.5	355	25	155	115
90S	140	115	95	M8	3	190	135	24	M8X20	50	8	20	90	M25X1.5	400	30	155	115
90L	140	115	95	M8	3	190	135	24	M8X20	50	8	20	90	M25X1.5	425	30	155	115
100L	160	130	110	M8	3.5	206	155	28	M10X22	60	8	24	100	M25X1.5	470	38	155	115
112	160	130	110	M8	3.5	235	175	28	M10X22	60	8	24	112	M32X1.5	490	35	210	140
132S	200	165	130	M10	3.5	275	188	38	M12X28	80	10	33	132	M32X1.5	565	40	210	140
132M	200	165	130	M10	3.5	275	188	38	M12X28	80	10	33	132	M32X1.5	600	40	210	140

Nota: Standard 1TC cu eliberare manuala.

Datele tehnice si performantele pot fi modificate

NOTE: 1TC standard with hand release.

Technical data and performances may change

6TS 7TS cuplu redus, motor cu frana / low torque, brake motor

63-132 B3

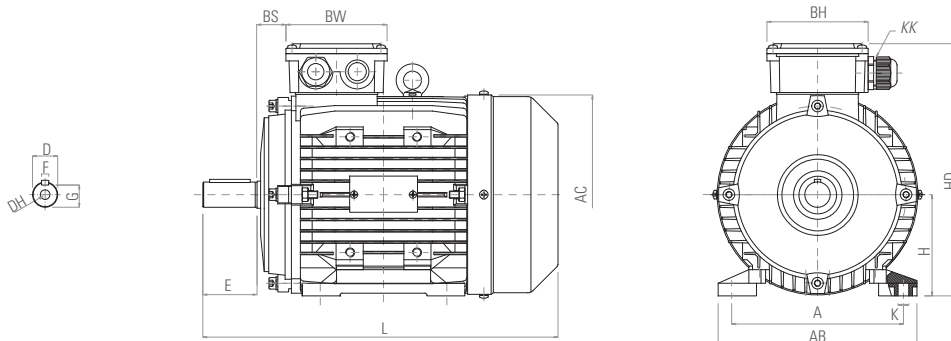

160-280 B3

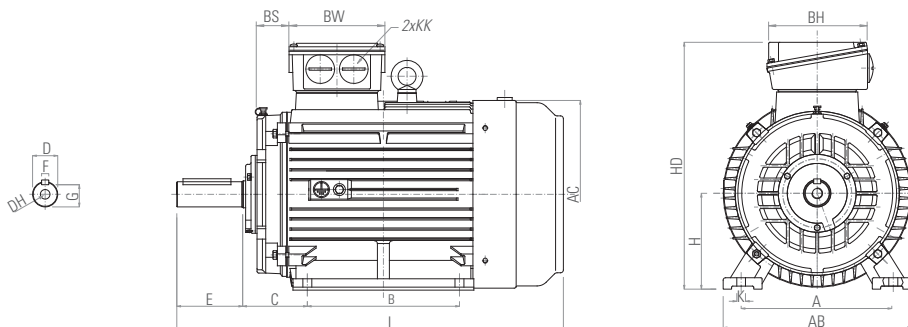

B3

	A	AB	B	C	K	AC	HD	D	DH	E	F	G	H	KK	L	BS	BW	BH
63-132 B3																		
56	90	110	71	36	5.8X8.8	115	153	9	M3X8	20	3	7.2	56	M20X1.5	195	14	88	88
63	100	120	80	40	7X10	130	168	11	M4X10	23	4	8.5	63	M20X1.5	215	14	94	94
71	112	132	90	45	7X10	145	183	14	M5X12	30	5	11	71	M20X1.5	255	20	94	94
80	125	160	100	50	10X10	165	212	19	M6X16	40	6	15.5	80	M20X1.5	290	27	105	105
90S	140	175	100	56	10X13	185	230	24	M8X20	50	8	20	90	M20X1.5	312	30	105	105
90L	140	175	125	56	10X13	185	230	24	M8X20	50	8	20	90	M20X1.5	337	30	105	105
90LB	140	175	125	56	10X13	185	230	24	M8X20	50	8	20	90	M20X1.5	365	30	105	105
100L	160	196	140	63	12X16	205	250	28	M10X22	60	8	24	100	M20X1.5	368	26	105	105
100LC	160	196	140	63	12X16	205	250	28	M10X22	60	8	24	100	M20X1.5	387	26	105	105
112	190	220	140	70	12X16	230	286	28	M10X22	60	8	24	112	M25X1.5	395	32	112	112
132S	216	252	140	89	12X16	270	319	38	M12X28	80	10	33	132	M25X1.5	436	38	112	112
132M	216	252	178	89	12X16	270	319	38	M12X28	80	10	33	132	M25X1.5	475	38	112	112
132MA-MB	216	252	178	89	12X16	270	319	38	M12X28	80	10	33	132	M25X1.5	500	38	112	112
160M	254	320	210	108	14X19	330	425	42	M16X36	110	12	37	160	M32X1.5	610	92	150	180
160L	254	320	254	108	14X19	330	425	42	M16X36	110	12	37	160	M32X1.5	650	92	150	180
180M	279	350	241	121	14X19	380	460	48	M16X36	110	14	42.5	180	M32X1.5	675	92	150	180
180L	279	350	279	121	14X19	380	460	48	M16X36	110	14	42.5	180	M32X1.5	715	92	150	180

Datele tehnice si performantele se pot modifica / Technical data and performances may change

63-132 B5

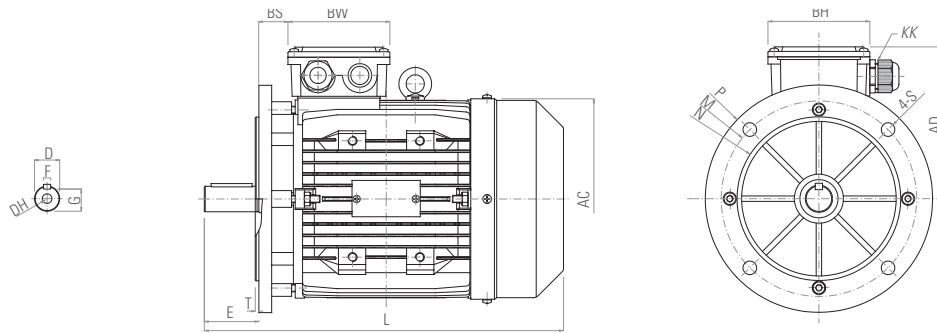

160-280 B5

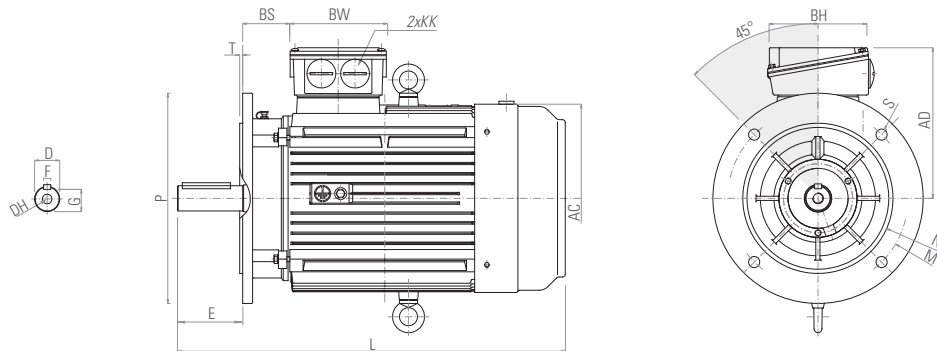

B5	P	M	N	S	T	AC	AD	D	DH	E	F	G	H	KK	L	BS	BW	BH
63-132 B5																		
56	120	100	80	7	3	115	97	9	M3X8	20	3	7.2	56	M20X1.5	195	14	88	88
63	140	115	95	10	3	130	105	11	M4X10	23	4	8.5	63	M16X1.5	215	14	94	94
71	160	130	110	10	3.5	145	112	14	M5X12	30	5	11	71	M20X1.5	255	20	94	94
80	200	165	130	12	3.5	165	132	19	M6X16	40	6	15.5	80	M20X1.5	290	27	105	105
90S	200	165	130	12	3.5	185	140	24	M8X20	50	8	20	90	M20X1.5	312	30	105	105
90L	200	165	130	12	3.5	185	140	24	M8X20	50	8	20	90	M20X1.5	337	30	105	105
90LB	200	165	130	12	3.5	185	140	24	M8X20	50	8	20	90	M20X1.5	365	30	105	105
100L	250	215	180	15	4	205	150	28	M10X22	60	8	24	100	M20X1.5	368	26	105	105
100LC	250	215	180	15	4	205	150	28	M10X22	60	8	24	100	M20X1.5	387	26	105	105
112	250	215	180	15	4	230	174	28	M10X22	60	8	24	112	M25X1.5	395	32	112	112
132S	300	265	230	15	4	270	187	38	M12X28	80	10	33	132	M25X1.5	436	38	112	112
132M	300	265	230	15	4	270	187	38	M12X28	80	10	33	132	M25X1.5	475	38	112	112
132MA-MB	300	265	230	15	4	270	187	38	M12X28	80	10	33	132	M25X1.5	500	38	112	112
160M	350	300	250	18.5	5	330	265	42	M16X36	110	12	37	160	M32X1.5	610	92	150	180
160L	350	300	250	18.5	5	330	265	42	M16X36	110	12	37	160	M32X1.5	650	92	150	180
180M	350	300	250	18.5	5	380	280	48	M16X36	110	14	42.5	180	M32X1.5	675	92	150	180
180L	350	300	250	18.5	5	380	280	48	M16X36	110	14	42.5	180	M32X1.5	715	92	150	180

Datele tehnice si performantele se pot modifica / Technical data and performances may change

6TS 7TS cuplu redus, motor cu frana / *low torque, brake motor*

56÷160

63-132 B14

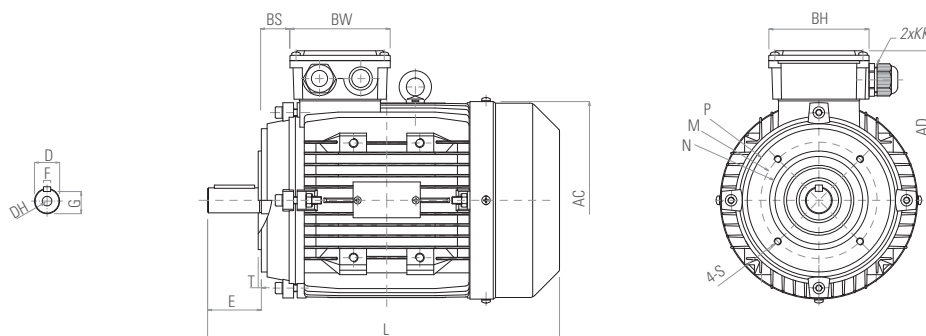

160-280 B14

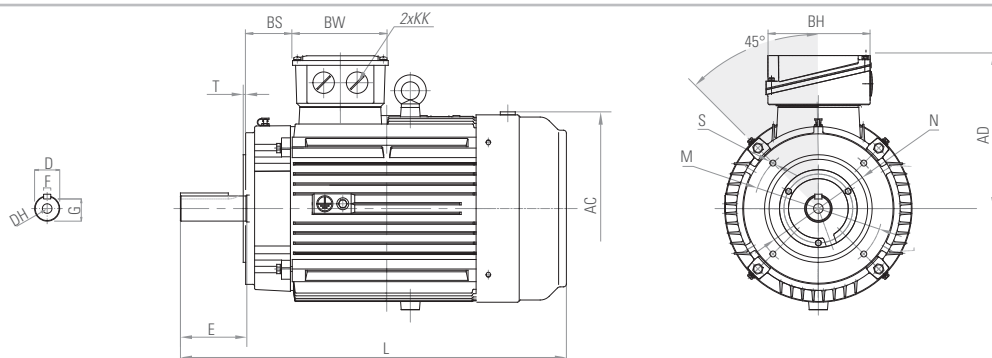

B14

	P	M	N	S	T	AC	AD	D	DH	E	F	G	H	KK	L	BS	BW	BH	
63-132 B14																			
56	80	65	50	M5	2.5	115	97	9	M3X8	20	3	7.2	56	M16X1.5	195	14	88	88	
63	90	75	60	M5	2.5	130	105	11	M4X10	23	4	8.5	63	M16X1.5	215	14	94	94	
71	105	85	70	M6	2.5	145	112	14	M5X12	30	5	11	71	M20X1.5	255	20	94	94	
80	120	100	80	M6	3	165	132	19	M6X16	40	6	15.5	80	M20X1.5	290	27	105	105	
90S	140	115	95	M8	3	185	140	24	M8X20	50	8	20	90	M20X1.5	312	30	105	105	
90L	140	115	95	M8	3	185	140	24	M8X20	50	8	20	90	M20X1.5	337	30	105	105	
90LB	140	115	95	M8	3	185	140	24	M8X20	50	8	20	90	M20X1.5	365	30	105	105	
100L	160	130	110	M8	3.5	205	150	28	M10X22	60	8	24	100	M20X1.5	368	26	105	105	
100LC	160	130	110	M8	3.5	205	150	28	M10X22	60	8	24	100	M20X1.5	387	26	105	105	
112	160	130	110	M8	3.5	230	174	28	M10X22	60	8	24	112	M25X1.5	395	32	112	112	
132S	200	165	130	M10	3.5	270	187	38	M12X28	80	10	33	132	M25X1.5	436	38	112	112	
132M	200	165	130	M10	3.5	270	187	38	M12X28	80	10	33	132	M25X1.5	475	38	112	112	
132MA-MB	200	165	130	M10	3.5	270	187	38	M12X28	80	10	33	132	M25X1.5	500	38	112	112	
160M	250	215	180	M12	4	330	265	42	M16X36	110	12	37	160	M32X1.5	610	92	150	180	
160L	250	215	180	M12	4	330	265	42	M16X36	110	12	37	160	M32X1.5	650	92	150	180	

Nota: pana la MEC71 inclus, flansa standard B14 are 8 gauri de montare. *Note: up to MEC71 included, the standard B14 flange has 8 mounting holes.*
 Datele tehnice si performantele pot fi modificate. *Technical data and performances may change*

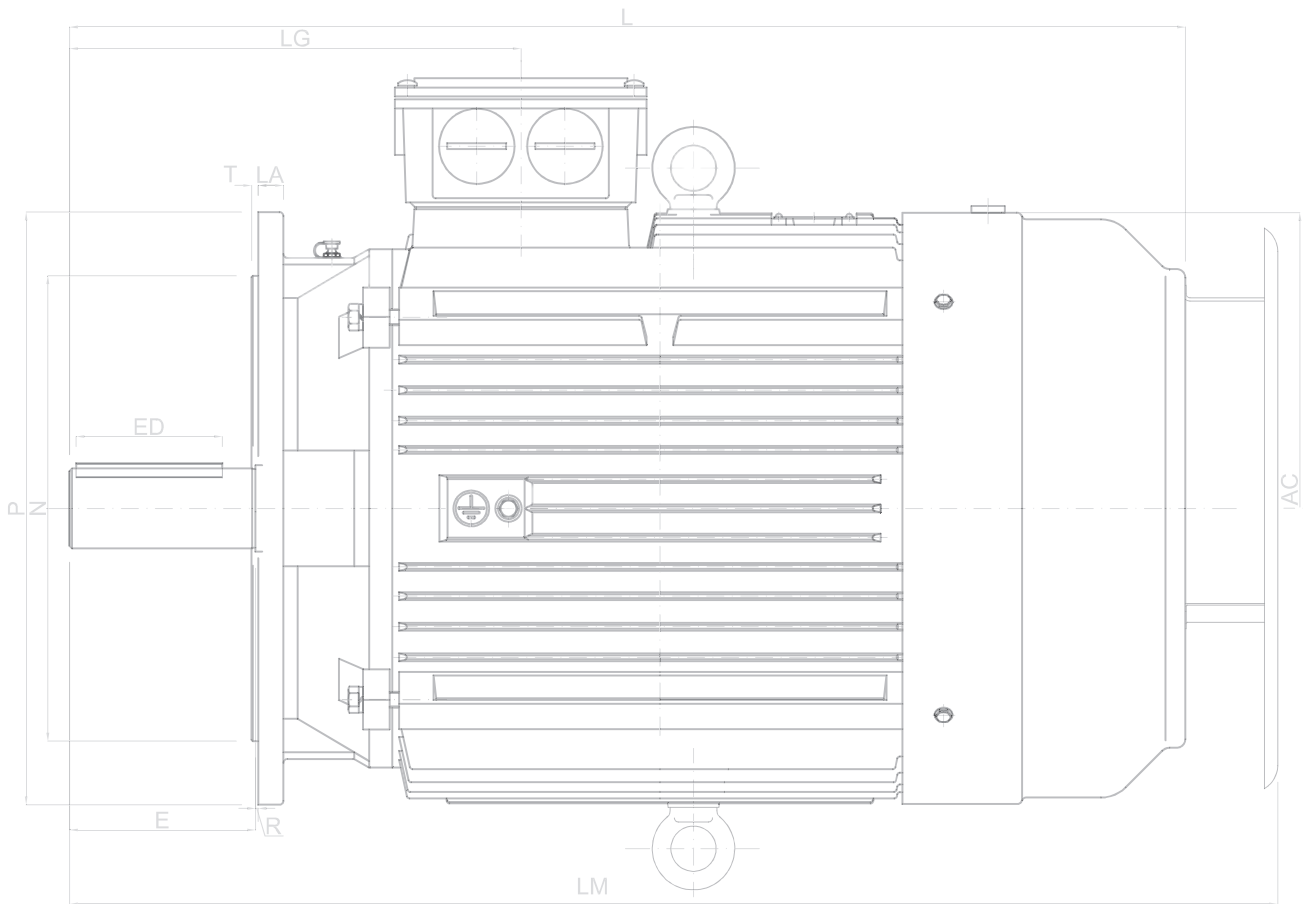
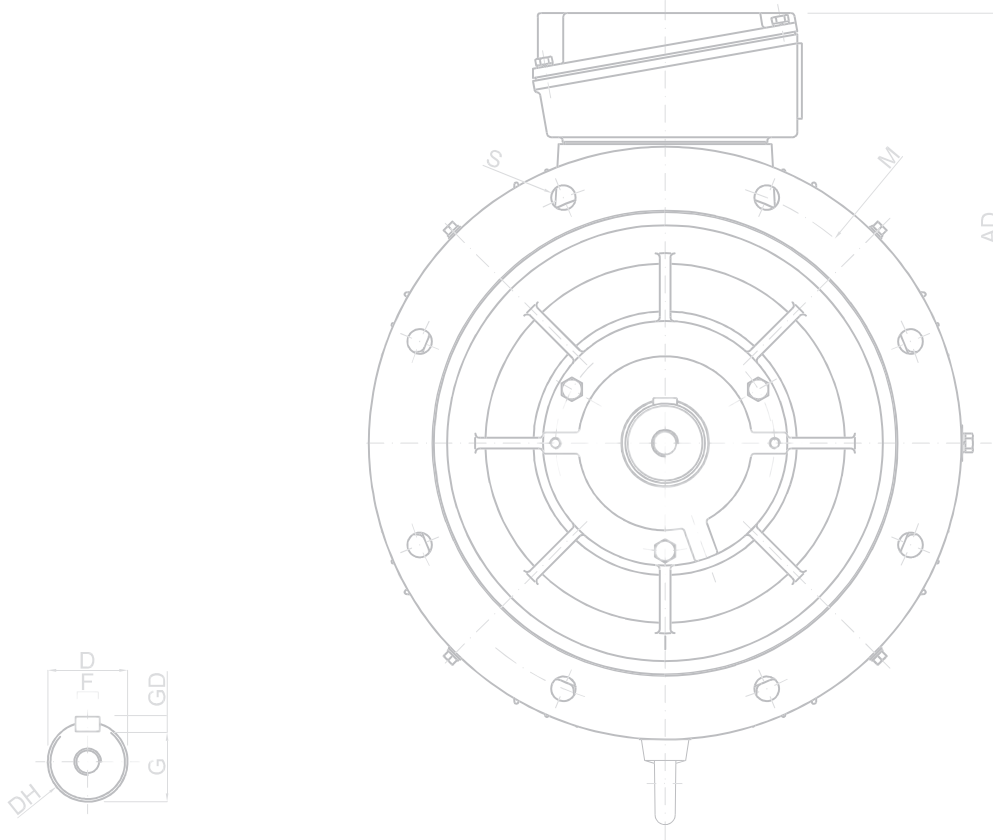

◆ 8.7 Racire forzata si dimensiuni motor encoder
Forced cooling and encoder motor dimension

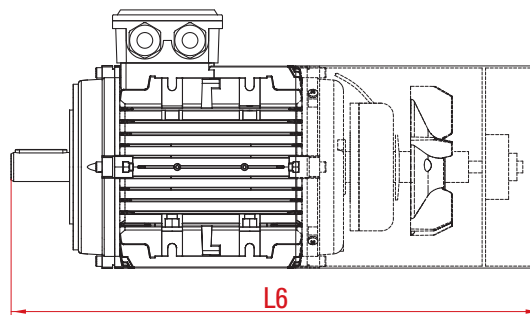
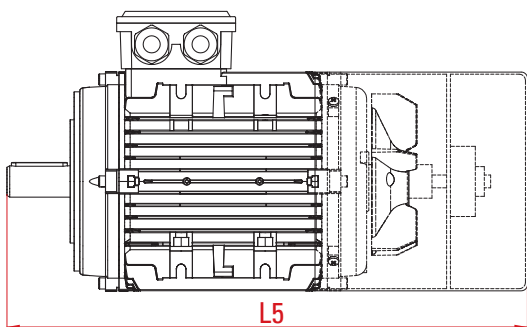
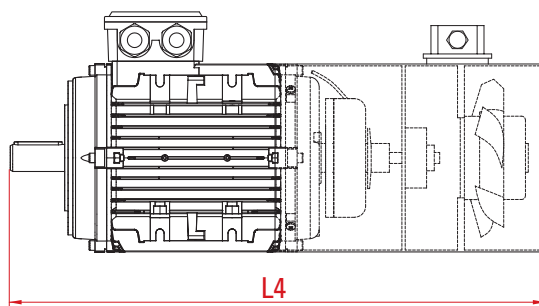
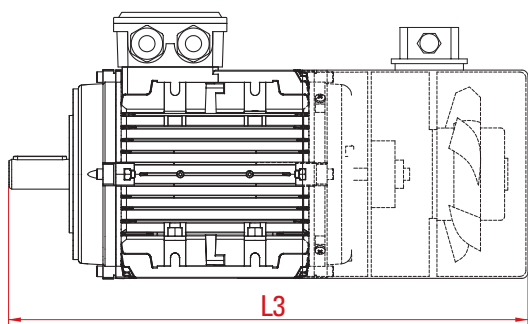
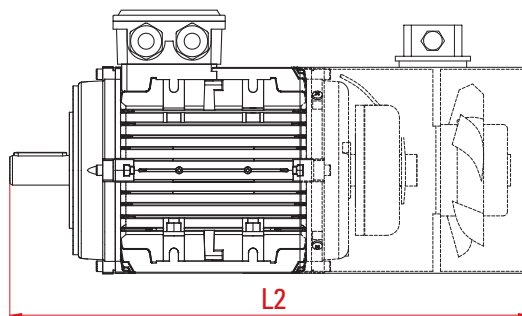
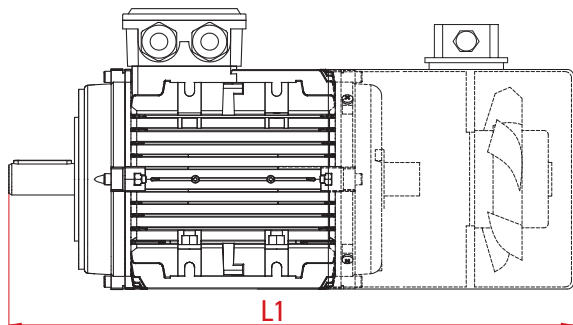

Racire fortata si dimensiunea mesei motorului encoder

Forced cooling and encoder motor table dimension

Frame	Motoare cu polaritate simpla si dubla Single and double polarity motors				Motoare cu frana cu polaritate simpla si dubla Brake single and double polarity motors				Motoare compacte cu frana cu polaritate simpla si dubla / Compact brake single and double polarity motors			
	aluminiu / aluminium 6T3 6T2 6T1 6P 6V fonta / cast iron 7T3 7T2 7T1 7P 7V				aluminiu / aluminium 6TC 6TK 6PC 6PK fonta / cast iron 7TC 7TK 7PC 7PK				aluminiu / aluminium 6TS 6PS fonta / cast iron 7TS 7PS			
	SV1/SV3	SV36	SV3/SV1 + ENC	ENC	SV1/SV3	SV36	SV3/SV1 + ENC	ENC	SV3/SV1	SV36	SV3/SV1 + ENC	ENC
	L1	L1	L3	L5	L2	L2	L4	L6	L1	L1	L4	L6
63	300	332	300	265	355	387	425	340	300	332	405	265
71	340	377	340	305	395	432	465	380	340	377	445	305
80	377	415	377	327	445	483	515	415	377	415	495	327
90S	404	439	404	362	462	497	532	440	404	439	512	362
90L	429	464	429	387	487	522	557	465	429	464	537	387
100L	470	498	470	425	555	583	625	530	470	498	605	425
112	492	515	492	450	582	605	652	560	492	515	632	450
132S	600	632	600	510	670	702	740	600	600	632	720	510
132M	640	672	640	550	710	742	795	640	640	672	775	550
160M	790	832	790	720	870	912	955	825	790	832	935	720
160L	815	857	815	745	920	962	1005	875	815	857	985	745
180M	855	892	855	785	930	967	1015	885	855	892	995	785
180L	905	942	905	835	980	1017	1065	935	905	942	1045	835
200L	885	935	885	845	980	1030	1065	965				
225S4	970	1125	970	895	1065	1220	1150	1015				
225M2	960	1115	960	885	1095	1250	1180	1045				
225M4-8	995	1150	995	920	1095	1250	1180	1045				
250M2	1115	1167	1115	1000	1255	1307	1340	1165				
250M4-8	1120	1172	1120	1005	1255	1307	1340	1165				
280S2	1150	1198	1150	1030	1320	1368	1405	1225				
280S4-8	1155	1203	1155	1035	1340	1388	1425	1245				
280M2	1190	1238	1190	1070	1360	1408	1445	1265				
280M4-8	1195	1243	1195	1075	1380	1428	1465	1285				
315S2	1310	1350	1310	1210								
315S4-8	1345	1385	1345	1245								
315M2	1420	1460	1420	1320								
315M4-8	1455	1495	1455	1355								
315L2	1425	1465	1425	1325								
315L4-8	1470	1510	1470	1370								
355M2	1710	1750	1710	1570								
355M4-8	1840	1880	1840	1700								
355L2	1810	1850	1810	1670								
355L4-8	1870	1910	1870	1730								

Nota: dimensiunile sunt aproximative si se refera la componentele standard (racire fortata, frane, encoder)

Note: the dimensions are approximate and refer to the standard components (forced cooling, brakes, encoder)

(tab. 45)

◆ 9.1 Piese de schimb / Spare parts

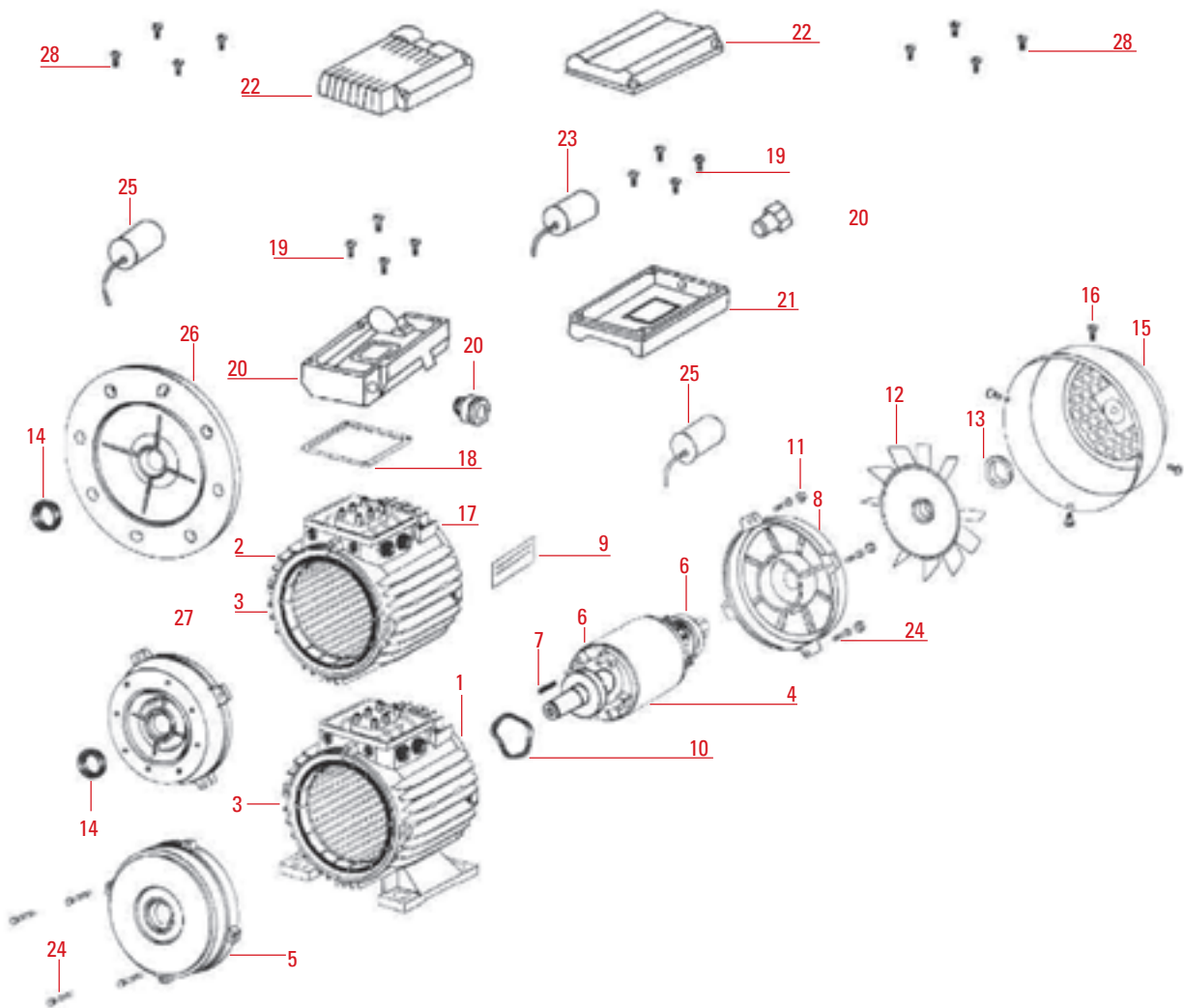

Piese de schimb pentru motoare din aluminiu / Aluminium motor spare parts

1.	Carcasa B3	Casing B3	15.	Capac ventilator	Fan cover
2.	Carcasa B5	Casing B5	16.	Suruburi pentru capacul ventilatorului	Screws for fan cover
3.	Stator bobinat	Wound stator	17.	Placa de borne completa	Complete terminal board
4.	Arbore si rotor	Shaft and rotor	18.	Etansare borne IP55	Terminal seal IP55
5.	Placuta frontala	Front endshield	19.	Suruburi pentru cutia de borne IP55	Screws for terminal box IP55
6.	Rulmenti	Bearings	20.	Presetupa cablu	Cable gland
7.	Cheie	Key	21.	Cutie de borne IP65 (baza)	Terminal box IP65 (base)
8.	Placuta spate	Back endshield	22.	Cutie de borne IP65 (capac)	Terminal box IP65 (cover)
9.	Placa	Plate	23.	Condensator de functionare	Run capacitor
10.	Inel de compensare	Compensation ring	24.	Suruburi stift de montare	Mounting stud screws
11.	Suruburi si piulite	Bolts and nuts	25.	Condensator de pornire	Start capacitor
12.	Ventilator de racire	Cooling fan	26.	Flansa B5	Flange B5
13.	Saiba de fixare a ventilatorului	Fan clamping washer	27.	Flansa B14	Flange B14
14.	Inel de etansare	Sealing ring	28.	Suruburi pentru placa de borne IP65	Screws for terminal board IP65

(tab. 46)

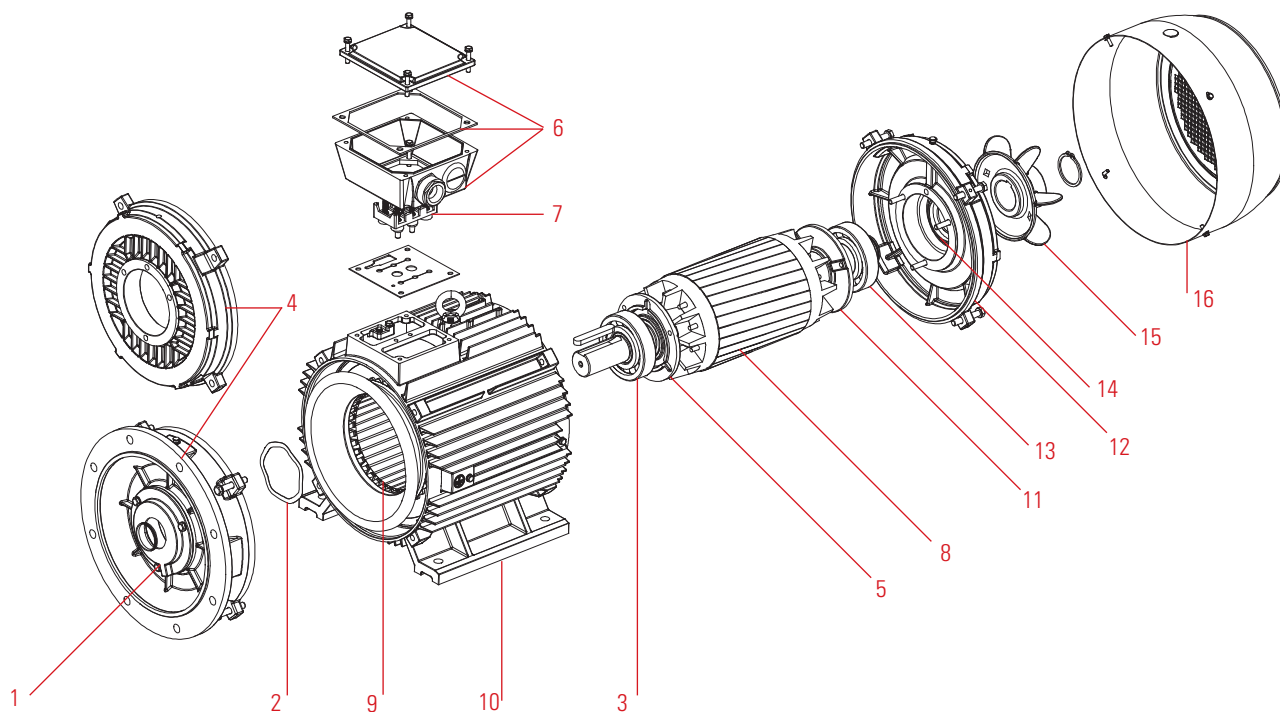

Piese de schimb pentru motoare din fonta / Cast iron motor spare parts

1.	Capac exterior al rulmentului cu garnitura de etansare	<i>Outer bearing cap with oil seal</i>
2.	Inel de compensare	<i>Compensation ring</i>
3.	Rulment fata	<i>Front bearing</i>
4.	Placuta rulment fata	<i>Front endshield</i>
5.	Capac interior al rulmentului	<i>Inner bearing cap</i>
6.	Cutie de borne	<i>Terminal box</i>
7.	Placa de borne	<i>Terminal board</i>
8.	Rotor	<i>Rotor</i>
9.	Stator bobinat	<i>Wound stator</i>
10.	Carcasa	<i>Casing</i>
11.	Capac interior al rulmentului spate	<i>Inner bearing rear cap</i>
12.	Placuta rulment spate	<i>Back endshield</i>
13.	Rulment spate	<i>Rear bearing</i>
14.	Capac exterior al rulmentului cu garnitura de etansare	<i>Outer bearing cap with oil seal</i>
15.	Ventilator de racire	<i>Cooling fan</i>
16.	Capac ventilator	<i>Fan cap</i>

(tab. 47)

◆ 9.2 Diagrame de conectare / *Connection diagrams*

Motoare trifazate / *Three-phase motors*

◆ 9.2.1 Viteza unica / *Single Speed*



◆ 9.2.2 Viteza dubla (2 infasurari) / *Double Speed (2 windings)*

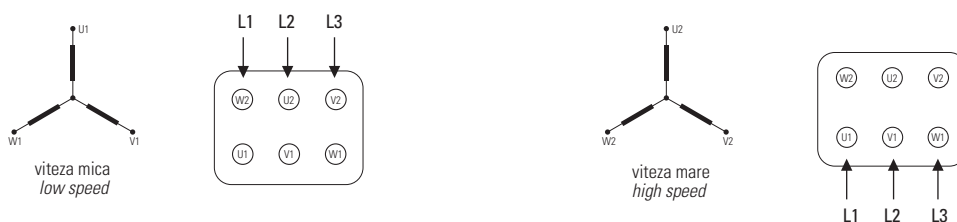

◆ 9.2.3 Viteza dubla, Dahlander, cuplu constant / *Double speed, Dahlander, constant torque*



◆ 9.2.4 Viteza dubla, Dahlander, cuplu patrat / *Double speed, Dahlander, quadratic torque*

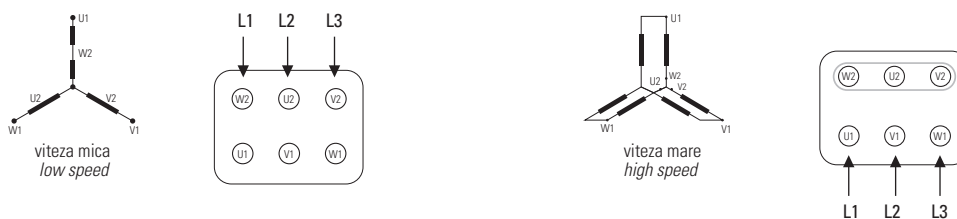

◆ 9.2.5 Motor monofazat / *Single-phase motor*



◆ 9.2.6 Conexiune frana AC tip C C-type AC brake connection

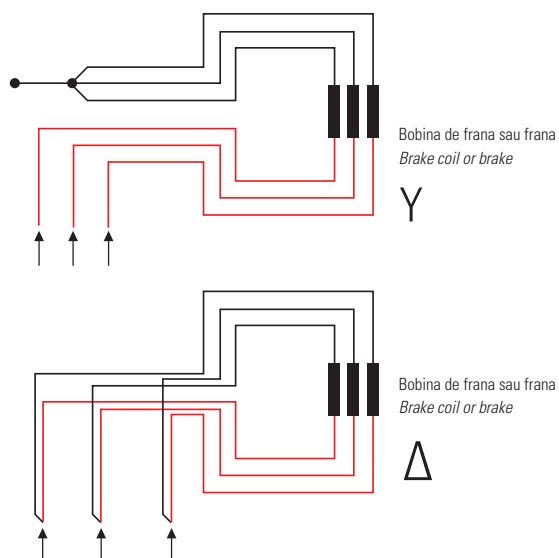

◆ 9.2.7 Alimentare directa cu frana / Direct brake power supply Motor trifazat / Three-phase motor

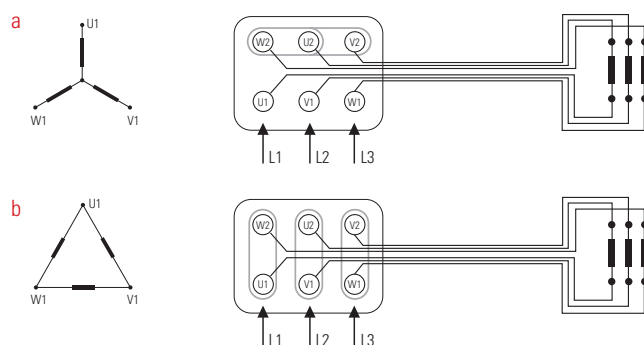

◆ 9.2.8 Alimentare separata pentru frana / Separated brake power supply Motor trifazat / Three-phase motor

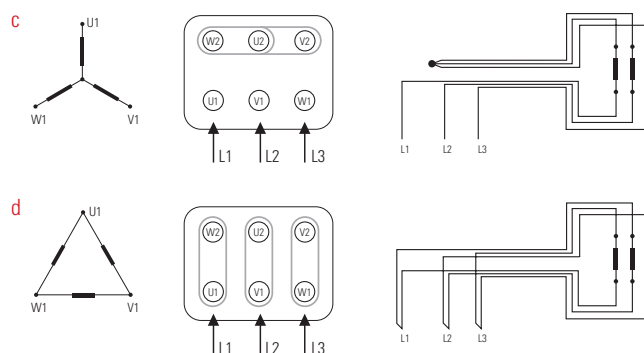

◆ 9.2.9 Motor cu 2 viteze, infasurare simpla / 2-Speed motor, single winding

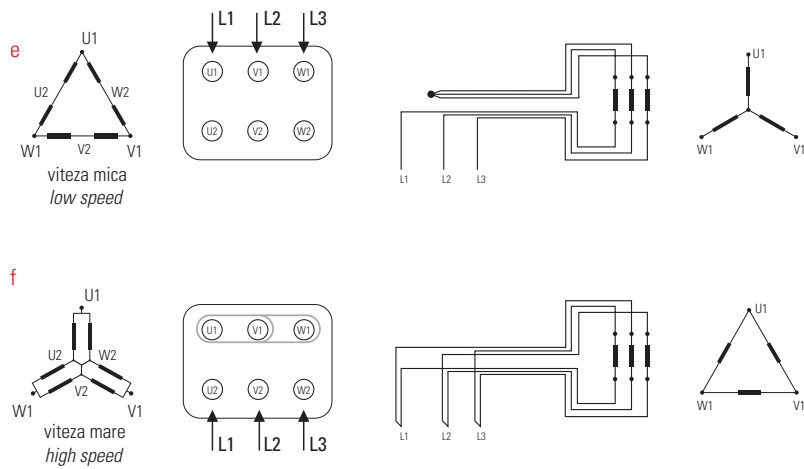

◆ 9.2.10 Motor cu 2 viteze, infasurare dubla / 2-Speed motor, double winding

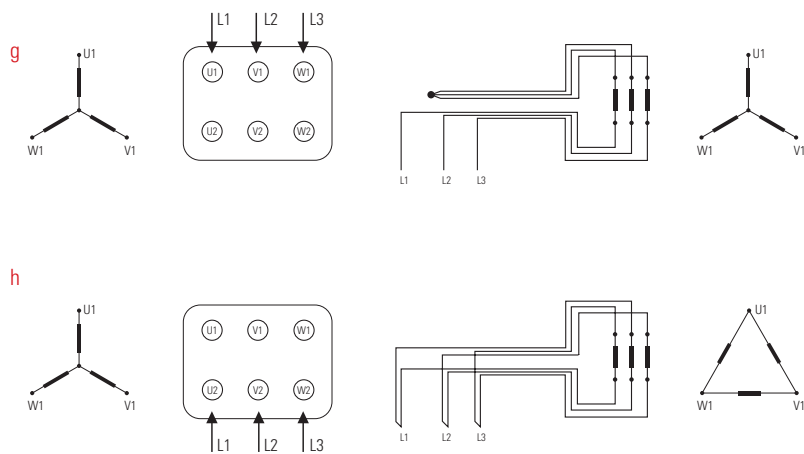

◆ 9.2.11 Conexiune frana CC tip S, K, H, R
S, K, H, R-type DC brake connection

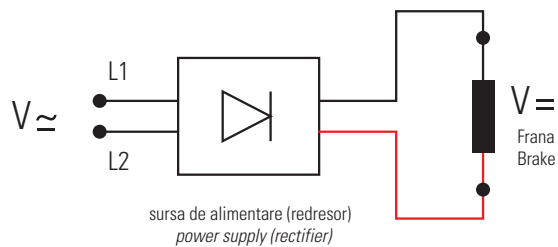

Alimentare directa cu frana / Direct brake power supply

◆ 9.2.12 Motor trifazat / *Three-phase motor*

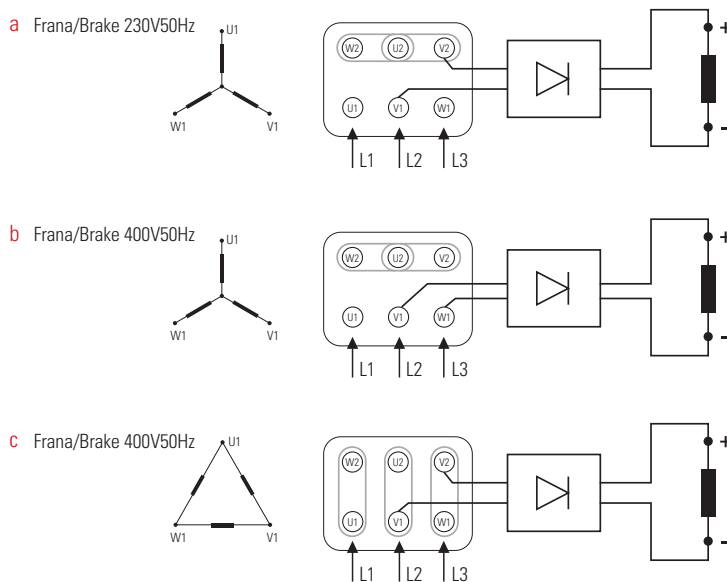

◆ 9.2.13 Motor monofazat / *Single-phase motor*

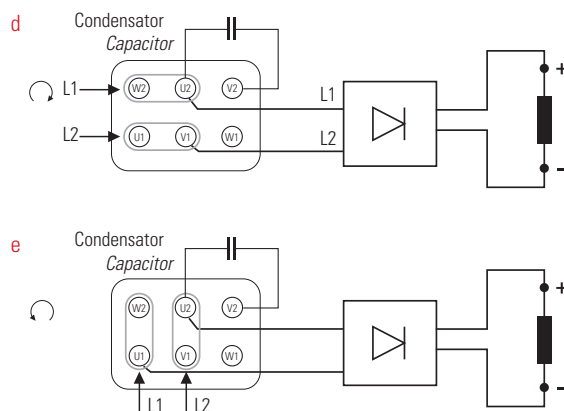

Alimentare separata cu frana / Brake separated power supply

◆ 9.2.14 Motor trifazat / Three-phase motor

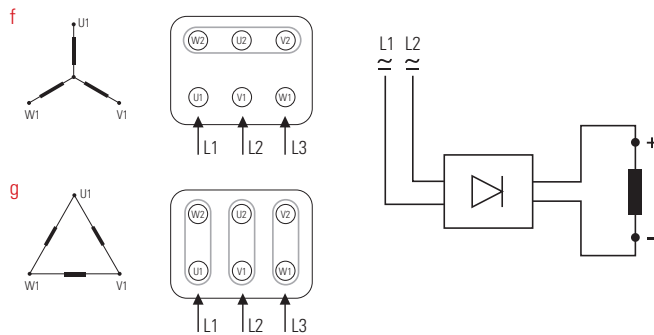

◆ 9.2.15 Motor cu 2 viteze, infasurare simpla / 2-Speed motor, single winding

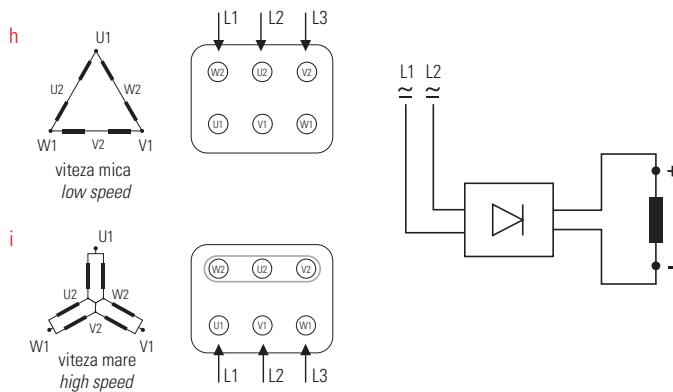

◆ 9.2.16 Motor de viteza, cu infasurare dubla / 2-Speed motor, double winding

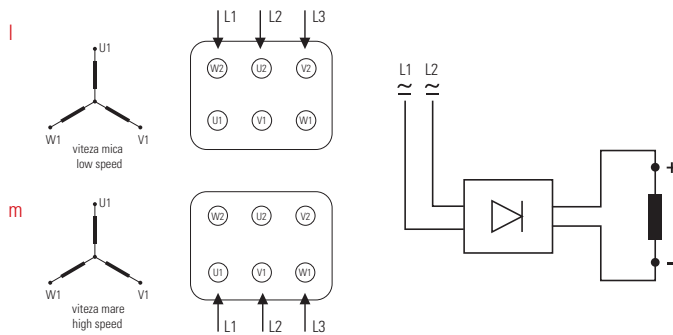

◆ 9.2.17 Motor monofazat / Single-phase motor

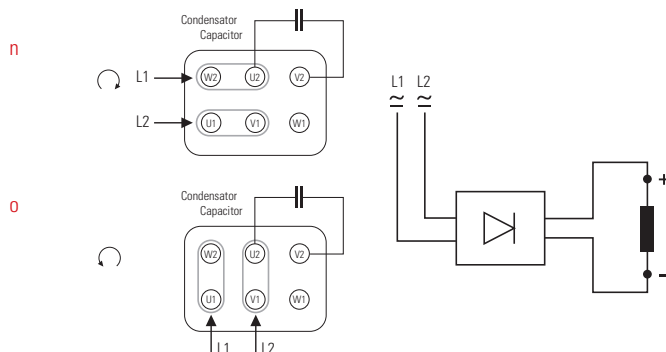

◆ 9.3 Cutie de borne / Terminal box

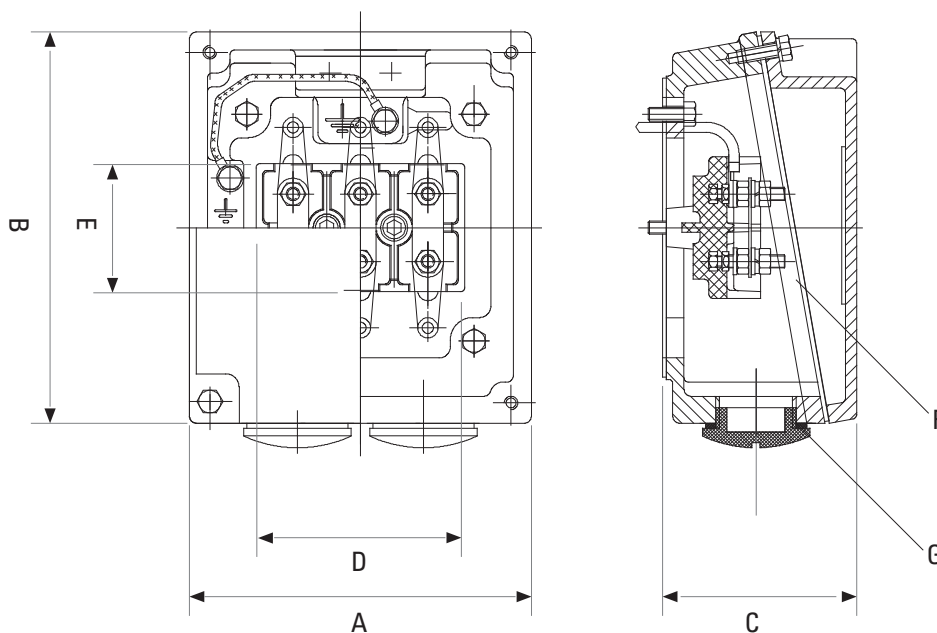

MEC	dimensiunea cutiei de borne	dimensiunea placii de borne	diametrul prezoanelor	diametrul presetupelor
	terminal box size	terminal board size	stud bolts diameter	cable glands diameter
	(A x B x C mm)	(D x E mm)	(F)	(G)
56	88x88x45	42x27	M4	M20x1.5
63-71	94x94x45	42x27	M4	M20x1.5
80-90-100	105x105x52	50x32	M4	M20x1.5
112-132	112x112x52	65x40	M5	M25x1.5
160-180	155x177x87	94x58	M6	M32x1.5
200-225	179x215x107	114x68	M8	M40x1.5
250-280	217x261x120	132x88	M10	M50x1.5
315	279x331x165	168x118	M12	M63x1.5
355	334x410x278	200x200	M20	M63x1.5

(tab. 48)

◆ 9.5 Legenda / Legend

Simboluri Symbols	Unitati de masura Unit of measurement	Descriere	Description
kW	kW	putere de iesire	rated output
hp	horse power	putere de iesire	rated output
rpm	rotations per minute	viteza de rotatie a arborelui la sarcina maxima	shaft speed at full load
η % 100% load	%	eficienta la sarcina maxima	efficiency at full load
η % 75% load	%	eficienta la o sarcina de 75%	efficiency at 75% load
η % 50% load	%	eficienta la o sarcina de 50%	efficiency at 50% load
$\cos\phi$	/	factor de putere	power factor
I_n	A	curent nominal la sarcina maxima	rated load at full current
I_s/I_n	/	curent de pornire / I_n	full load current
C_n	Nm	cuplu nominal	starting current / I_n
C_s/C_n	/	cuplu de pornire / C_n	torque for starting / C_n
C_{max}/C_n	/	cuplu maxim / C_n	starting torque / C_n
C_f Brake torque	Nm	cuplu maxim de franare	maximum brake torque
Run Cap.	μ F	condensator de functionare (450 VAC)	run capacitor (450Vac)
Start Cap.	μ F	condensator de pornire (250 VAC-300 VAC)	start capacitor (250Vac-300Vac)
kg	kg	greutatea motorului	weight of motor

Nota: datele de performanta sunt valabile pentru alimentarea cu 400V50Hz (motoare trifazate) si 230V50Hz (motoare monofazate)
 Note: performance data are valid for 400V50Hz (three-phase motors) and 230V50Hz (single-phase motors) power supply

◆ 9.6 Indexul tabelelor / Index of tables

Tabella	Table	pag.
tab.1 Standarde de referinta	Reference standards	11
tab.2 Compararea standardelor internationale	Comparison of international standards	15
tab.3 Valori minime de randament (IEC 60034-30-1: 2014)	Minimum efficiency values (IEC 60034-30-1: 2014)	16
tab.4 Legenda de citire si cod de identificare	Reading key and identification code	18
tab.5 Configuratii si aranjamente de montare	Configurations and mounting arrangements	21
tab.6 Dimensiuni cuplaj arbore principal-flansa (IEC 60072-1)	Main Shaft-Flange coupling dimensions (IEC 60072-1)	22
tab.7 Materiale	Materials	23
tab.8 Tolerante electrice	Electric tolerances	24
tab.9 Tolerante mecanice	Mechanical tolerances	24
tab.10 Niveluri sonore	Sound levels	25
tab.11 Vibratii	Vibrations	25
tab.12 Metoda de racire	Cooling method	26
tab.13 Nivel de protectie IP	IP protection level	27
tab.14 Variatii ale puterii in functie de conditiile de mediu	Variations of power related to environmental conditions	29
tab.15 Variatia specificatiilor nominale	Variation of nominal specifications	29
tab.16 Tipul de serviciu si puterea admisibila	Type of duty and allowable power	31
tab.17 Sarcini radiale si axiale	Radial and axial loads	35
tab.18 Specificatii rulmenti	Bearing specifications	37
tab.19 Dimensiuni rulmenti si intervale de lubrifiere	Bearing dimensions and lubricating intervals	38

Tabel	Table	pag.
tab.20	Instalarea rulmentilor pentru motoare din fonta	39
tab.21	Dimensiunile garniturii de etansare	40
tab.22	Redresoare	68
tab.23	Specificatii tehnice frana S	70
tab.24	Schema de conectare a franei si tensiunea admisa - S	70
tab.25	Timpi de interventie - S	71
tab.26	Specificatii tehnice frana K	74
tab.27	Schema de conectare a franei si tensiunea admisa - K	74
tab.28	Reglarea cuplului de franare - K	75
tab.29	Timpi de interventie - K	75
tab.30	Specificatii tehnice frana H	77
tab.31	Specificatii tehnice frana R	79
tab.32	Schema de conectare a franei si tensiunea admisa - R	79
tab.33	Timpi de interventie - R	80
tab.34	Specificatii tehnice frana C	82
tab.35	Reglarea cuplului de franare - C	83
tab.36	Schema de conectare a franei si tensiunea admisa - C	84
tab.37	Timpi de interventie - C	84
tab.38	Clase de temperatura pentru atmosfere gazoase	97
tab.39	Clasificarea echipamentului	98
tab.40	Nivelul de protectie asigurat de echipament	98
tab.41	Puterea incalzitorului anticondens	102
tab.42	Performante de racire fortata SV3	112
tab.43	Performante de racire fortata SV1	113
tab.44	Performante de racire fortata SV36	113
tab.45	Tabel de dimensiuni ale motoarelor cu racire fortata sau encoder	151
tab.46	Piese de schimb pentru motoare din aluminiu	152
tab.47	Piese de schimb pentru motoare din fonta	153
tab.48	Placi de borne	159